

TECNICO[®]

N A T U R A L L I G H T

Catalogue

14

- _ Extruded profiles
- _ Linear profiles
- _ Recessed lights
- _ Wall, ceiling and pendant lights



Gypsum

Gesso
Gips
Escayola
Гипс

Tecnico's shapes are inspired by the gypsum's endless use possibilities. This natural material is excellent for environmentally-friendly and green building purposes, because it is non-toxic, with a neutral pH and non-combustible.

Tecnico's products are designed to blend in with contemporary residential architecture and to last over time. All of Tecnico's products use high efficiency lighting sources (build-in LEDs or LED lights), which emit a lot of light with limited energy consumption.

Infrared analysis on Tecnico gypsum, by the Catas S.p.A. testing lab: the analysis has been carried out with the ATR technique, with direct product contact with the sensor crystal. The resulting infrared spectrum shows only the presence of calcium sulphate dihydrate - commonly known as Gypsum - in the product material.

IT Le forme di Tecnico nascono dalle infinite possibilità date dall'utilizzo del gesso, un materiale naturale, ideale sotto l'aspetto ecologico e bioedile perché atossico, con un pH neutro e non risulta combustibile.

I prodotti di Tecnico sono pensati per integrarsi con l'architettura domestica contemporanea e per durare nel tempo. Tutti i prodotti Tecnico utilizzano sorgenti luminose (LED integrati o lampadine LED) ad alta efficienza, che emettono quindi una grande quantità di luce a fronte di un consumo contenuto.

Analisi infrarossa sui gessi Tecnico da parte del Laboratorio di prova Catas S.p.A.: l'analisi è stata condotta con la tecnica ATR per contatto diretto del prodotto con il cristallo del sensore. Lo spettro infrarosso risultante mostra nella materia del prodotto la sola presenza di Solfato di Calcio Bihidrato, conosciuto con il nome comune di Gesso.

DE Die Formen von Tecnico ergeben sich aus den unendlichen Möglichkeiten, die die Verwendung von Gips bietet, einem natürlichen Material, das aus ökologischer und baubiologischer Sicht ideal ist, da es ungiftig, pH-neutral und nicht brennbar ist.

Die Produkte von Tecnico sind so konzipiert, dass sie sich in die zeitgenössische Wohnarchitektur einfügen und langlebig sind. Alle Tecnico-Produkte verwenden hocheffiziente Lichtquellen (integrierte LEDs oder LED-Glühbirnen), die daher eine große Lichtmenge bei geringem Verbrauch abgeben.

Infrarot-Analyse von Gips von Tecnico durch das Prüflabor Catas S.p.A: die Analyse wurde mit der ATR-Technik durch direkten Kontakt des Produkts mit dem Sensor-kristall durchgeführt. Das daraus resultierende Infrarotspektrum zeigt im Produktmaterial nur das Vorhandensein von Calciumsulfat-Dihydrat, das unter dem Namen Gips bekannt ist.

ES Las formas de Tecnico nacen de las infinitas posibilidades que brinda el uso de la escayola, un material natural, ideal desde el punto de vista ecológico y de la construcción ecológica ya que no es tóxico, tiene un pH neutro y no es combustible.

Los productos Tecnico están diseñados para integrarse con la arquitectura doméstica contemporánea y durar con el paso del tiempo. Todos los productos Tecnico utilizan fuentes luminosas (leds integrados o bombillas led) de alta eficiencia, que emiten una gran cantidad de luz con un consumo muy reducido.

Análisis técnico de infrarrojos sobre yesos por parte del laboratorio de ensayos Catas S.p.A: el análisis se ha realizado con la técnica ATR por contacto directo del producto con el cristal del sensor. El espectro infrarrojo resultante muestra en la materia del producto únicamente la presencia de hemihidrato de sulfato de calcio conocido con el nombre común de yeso.

RU Разнообразные формы Tecnico рождаются из бесчисленных возможностей, открывающихся благодаря использованию гипса - натурального материала, идеального с точки зрения экологичности и «зеленого» строительства, поскольку он является нетоксичным, негорючим и имеет нейтральный pH.

Изделия Tecnico прекрасно вписываются в современные домашние интерьеры и характеризуются длительным сроком службы. Вся продукция Tecnico комплектуется высокоэффективными источниками света (встроенные светодиоды или светодиодные лампы), которые дают много света при невысоком потреблении электроэнергии.

Инфракрасный анализ гипсовых изделий Tecnico, проведенный испытательной лабораторией Catas S.p.A: анализ проводился методом ИК-спектроскопии нарушенного полного внутреннего отражения, путем непосредственного контакта изделия с кристаллом датчика. Полученный инфракрасный спектр свидетельствует о том, что в веществе изделия содержится исключительно дигидрат сульфата кальция, известного как гипс.



CATAS
Testing Certification Research



Aluminium

Alluminio
Aluminium
Aluminio
Алюминий

Tecnico's core are extruded aluminium products. Naturally light, long-lasting, sturdy and oxidation-resistant, aluminium products increase their sustainability thanks to their complete end-of-life recycling options.

High efficiency covers and LED sources can be easily removed to sort the different materials for recycling purposes.

IT Core del brand Tecnico sono i prodotti in alluminio estruso. Naturalmente leggeri, durevoli in quanto resistenti e non soggetti a ossidazione, i prodotti in alluminio aumentano la loro sostenibilità grazie alla completa riciclabilità di questo materiale.

Le coperture e le sorgenti LED ad alta efficienza possono essere facilmente disassemblate per riciclare separatamente i diversi materiali.

DE Die Kernkomponente von Tecnico sind stranggepresste Aluminiumprodukte.

Aluminiumprodukte sind von Natur aus leicht, langlebig, widerstandsfähig und oxidieren nicht. Dank der vollständigen Recyclebarkeit dieses Materials am Ende seiner Lebensdauer erhöhen sie die Nachhaltigkeit.

Die Abdeckungen und die hocheffizienten LED-Leuchtmittel können leicht demontiert werden, um die verschiedenen Materialien getrennt zu recyceln.

ES El alma de la marca Tecnico son los productos de aluminio extruido. Ligeros por naturaleza, duraderos gracias a su resistencia y no sometidos a oxidación, los productos de aluminio aumentan su sostenibilidad gracias a la completa capacidad de reciclaje de este material al final de su vida útil.

Los recubrimientos y las fuentes led de alta eficiencia se pueden desmontar fácilmente para reciclar los diferentes materiales por separado.

RU Центральное место в ассортименте продукции бренда Tecnico занимают изделия из экструдированного алюминия.

Натурально легкие, долговечные и прочные, не подверженные окислению изделия из алюминия являются особо экологичными благодаря полному рециклингу этого материала по окончании эксплуатации изделия.

Корпуса и высокоэффективные светодиодные источники света можно легко демонтировать и подвергнуть дифференцированной вторичной переработке.



5 years warranty

5 anni di garanzia
5 Jahre Garantie
5 años de garantía
5 лет гарантии

The warranty on Tecnico Natural Light products can be extended for up to 5 years. Extending the warranty is very simple: just enter the dedicated area on the website tecnicolighting.it, or use the QR Code that you will find in the assembly instructions inside the box or on this page of the catalogue. Fill out the form to extend the warranty.

IT Per i prodotti Tecnico Natural Light è possibile estendere la garanzia fino a 5 anni. Estendere la garanzia è molto semplice: basta accedere all'area dedicata sul sito tecnicolighting.it, oppure tramite il QR Code che si trova nelle istruzioni di montaggio all'interno della scatola o nella presente pagina di catalogo; si compila il Form e la Garanzia è estesa.

ES Para los productos Tecnico Natural Light es posible ampliar la garantía hasta 5 años. Ampliar la garantía es muy simple: basta con acceder al área dedicada en el sitio web tecnicolighting.it o utilizar el código QR que se encuentra en las instrucciones de montaje dentro de la caja o en esta página del catálogo; se debe rellenar el formulario y la garantía se extiende.

DE Für Tecnico Natural Light Produkte ist es möglich, die Garantie auf bis zu 5 Jahre zu verlängern. Die Verlängerung der Garantie ist sehr einfach: Sie müssen nur den entsprechenden Bereich auf der Website tecnicolighting.it aufrufen oder den QR-Code verwenden, der sich in der Montageanleitung in der Schachtel oder auf dieser Katalogseite befindet; füllen Sie das Formular aus und die Garantie wird verlängert.

RU На изделия Tecnico Natural Light гарантия может быть продлена до 5 лет. Процедура продления гарантии очень проста: достаточно зайти в специальный раздел на сайте tecnicolighting.it либо воспользоваться QR-кодом, указанным в инструкции по монтажу на внутренней части коробки или на этой странице каталога; заполните форму, и гарантия будет продлена.





_blank design studio

Designer

_blank design studio, established in 2013 by Federico Elli and Stefano Filipuzzi, is a design studio focused on industrial design and advertising.

Federico Elli graduated in industrial design and engineering at the Politecnico di Milano and is now a lecturer at the same university. In addition to his teaching career, he is also a successful industrial designer. Stefano Filipuzzi graduated in industrial design at the Politecnico di Milano. He has acquired over ten years experience as an art director and graphic designer, specialising in visual design across both print and digital outputs.

_blank design studio works with businesses in various sectors and has received awards and accolades for its work, such as from the Sharp Design Contest and Cristalplant Design Contest in 2013, as well as the special award from the Samsung Young Design Award in 2014. The studio was also selected as a finalist in the 2015 Young&Design award for its design of the Tombolo table and in 2019 for the Sforzin Illuminazione Linea project for Urban Lighting, which also won the 2020 Good Design Award. At the beginning of 2024 the studio was selected and awarded with the ADI Design Index 2023 for the Heylo project.

IT _blank design studio, fondato nel 2013 da Federico Elli e Stefano Filipuzzi, è uno studio di progettazione applicata alla produzione industriale e alla comunicazione.

Docente a contratto presso il Politecnico di Milano, Federico Elli, si laurea in Disegno e Ingegnerizzazione del prodotto industriale presso lo stesso Ateneo ed affianca alla carriera didattica quella di industrial designer. Stefano Filipuzzi, Laureato in Disegno industriale presso il Politecnico di Milano, lavora da oltre dieci anni come art director e graphic designer occupandosi di visual design sia nel campo della stampa che in quello digitale.

_blank design studio collabora con realtà aziendali in settori differenti, ha ricevuto premi e riconoscimenti per la sua attività quali lo Sharp Design Contest e il Cristalplant Design Contest nel 2013, il premio speciale al Samsung Young Design Award nel 2014 ed è stato finalista al Young&Design nel 2015 con il progetto del tavolo Tombolo e nel 2019 con il progetto Linea per Sforzin Illuminazione per Urban Lighting premiato nel 2020 anche con il Good Design Award. Ad inizio 2024 lo studio è stato selezionato e premiato con l'ADI Design Index 2023 per il progetto Heylo.

DE Beim 2013 von Federico Elli und Stefano Filipuzzi gegründeten _blank design studio handelt es sich um ein Planungsbüro, das in den Bereichen industrielle Produktion und Kommunikation tätig ist.

Federico Elli hat an der Polytechnischen Universität Mailand Design und Engineering von Industrieprodukten studiert. Er hat an dieser Universität einen Lehrauftrag als Dozent inne und ist gleichzeitig als Industrial Designer tätig. Auch Stefano Filipuzzi hat Design und Engineering von Industrieprodukten an der Polytechnischen Universität Mailand studiert, arbeitet seit mehr als zehn Jahren als Art director und Graphic Designer und kümmert sich in den Bereichen Druck und Digital um die optische Gestaltung.

Das _blank design studio arbeitet mit Betrieben aus unterschiedlichen Branchen zusammen und hat für seine Tätigkeit Preise und Anerkennungen erhalten wie z.B. den Sharp Design Contest und den Cristalplant Design Contest im Jahr 2013, den Sonderpreis beim Samsung Young Design Award im Jahr 2014 und wurde beim Wettbewerb Young&Design 2015 mit dem Tischprojekt Tombolo Finalist und im Jahr 2019 mit dem Projekt Linea für die Firma Sforzin Illuminazione für Urban Lighting, das 2020 auch den Good Design Award erhielt. Anfang 2024 wurde das Studio für das Heylo-Projekt ausgewählt und mit dem ADI Design Index 2023 ausgezeichnet.

ES _blank design studio, fundado en 2013 por Federico Elli y Stefano Filipuzzi, es un estudio de diseño enfocado a la producción industrial y a la comunicación.

Profesor contratado en el Politécnico de Milán, Federico Elli, se licencia en Diseño e Ingeniería del producto industrial en dicha universidad y combina la carrera didáctica con aquella de diseñador industrial. Stefano Filipuzzi, licenciado en Diseño Industrial por el Politécnico de Milán, lleva más de diez años trabajando como art director y graphic designer, ocupándose de visual design tanto en el sector de la prensa como en el sector digital.

_blank design studio colabora con empresas que operan en diferentes sectores, ha recibido premios y reconocimientos por su actividad, como el Sharp Design Contest y el Cristalplant Design Contest en 2013, el premio especial Samsung Young Design Award en 2014 y fue finalista del Young&Design en 2015 con el proyecto de la mesa Tombolo y en 2019 con el proyecto Linea para Sforzin Illuminazione para Urban Lighting premiado también en 2020 con el Good Design Award. A principios de 2024 el estudio fue seleccionado y galardonado con el ADI Design Index 2023 por el proyecto Heylo.

RU _blank design studio, основанная в 2013 году Федерико Элли и Стефано Филипуцци, - это студия дизайна, работающая в сфере промышленного дизайна и коммуникации.

Фредерико Элли окончил факультет промышленного дизайна и инжиниринга в Политехническом институте Милана и в том же университете он сейчас преподает в качестве доцента, совмещая преподавательскую карьеру с деятельностью промышленного дизайнера. Стефано Филипуцци также окончил факультет промышленного дизайна в Политехническом институте Милана и более десяти лет работает художественным руководителем и графическим дизайнером в сфере визуального дизайна как в печатной, так и в цифровой областях.

Студия _blank design studio сотрудничает с компаниями в различных секторах и получила призы и награды за свою деятельность, такие как Конкурс дизайна Sharp и Конкурс дизайна Cristalplant в 2013 году, специальный приз на конкурсе Samsung Young Design Award в 2014 году, а также стала финалистом конкурса Young&Design в 2015 году с проектом стола Tombolo и в 2019 году - с проектом продукта Linea, который был разработан для Sforzin Illuminazione и вошел в каталог Urban Lighting; помимо этого, в 2020 году это изделие получило премию Good Design Award. В начале 2024 года студия была выбрана и награждена ADI Design Index 2023 за проект Heylo.

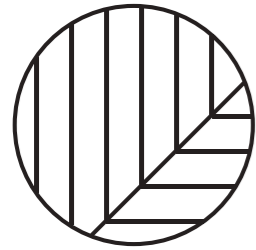

Acero.

Acero design studio

Designer

Milanese design studio specialized in designing products for lighting and furniture industry. Driven by the passion for innovation, the studio has been imagining and designing new objects since 2007.

By combining functionality and aesthetics, Acero experiments and investigates forms, materials and technologies.

IT Studio di design milanese specializzato nella progettazione di prodotti per il settore dell'illuminazione e dell'arredo. Mosso dalla passione per l'innovazione lo studio concepisce e disegna dal 2007 nuovi oggetti. Coniugando funzionalità ed estetica Acero sperimenta ed indaga forme, materiali e tecnologie.

ES Estudio milanés de diseño, especializado en proyecto de productos para el sector de la iluminación y la decoración. Desde 2007, impulsado por la pasión por la innovación, el Estudio idea y diseña nuevos objetos. Aunando funcionalidad y estética Acero experimenta e investiga formas, materiales y tecnologías.

DE Mailänder Designstudio, das auf die Gestaltung von Produkten für den Beleuchtungs- und Einrichtungssektor spezialisiert ist. Angetrieben von der Leidenschaft für Innovation konzipiert und entwirft das Studio seit 2007 neue Objekte. Acero verbindet Zweckmäßigkeit mit Ästhetik, ist experimentierfreudig und erforscht gern Formen, Materialien und Technologien.

RU Итальянская дизайн-студия, специализирующаяся на дизайне продукции для сферы освещения и интерьера. Движимая стремлением к инновациям, студия с 2007 года занимается разработкой и проектированием новых объектов. Комбинируя функциональность и эстетику, Acero создает и исследует формы, материалы и технологии.



Luca Artioli

Designer

Borned in 1967, after graduating in Graphic Design and Communication Luca Artioli started his career as a freelance illustrator and creative designer at AD Agencies. In 1994 he became senior designer in section Accessories for clothing, where he attended to accessory design and graphics applied to the product.

In 1997 he founded Studio BEATBOX. Bags, objects, graphics are the basis for Beatbox design works and the Studio collaborated with major Italian and foreign companies, including work experience in France, China and Japan.

From 2013 he is going on with his personal consulting business for companies. Elegance and balance are the basic elements and inspiring principles of his work.

IT Nato nel 1967, dopo aver conseguito il diploma di Graphic Designer e Comunicazione Luca Artioli avvia la sua attività professionale come illustratore e creativo freelance presso studi di pubblicità. Nel 1994 è senior designer per la progettazione di accessori per l'abbigliamento, dove cura il design per l'accessorio e la grafica applicata al prodotto.

Nel 1997 fonda lo Studio BEATBOX. Borse, oggettistica, grafica, sono alla base dell'attività di design dello Studio che collabora con importanti aziende italiane ed estere del settore, annoverando esperienze lavorative in Francia, Cina e Giappone.

Dal 2013 prosegue la sua personale attività di consulenza per le aziende. Eleganza ed equilibrio sono gli elementi fondanti e i principi ispiratori del suo lavoro.

DE 1967 geboren, beginnt Luca Artioli nach seinem Abschlusszeugnis in Graphic Design und Kommunikation seinen beruflichen Werdegang als Illustrator und kreativer Freiberufler in Werbeagenturen. 1994 ist er Senior Designer für den Entwurf von Bekleidungsaccessoires und kümmert sich um das Design des Accessoires und um die angewandte Produktgrafik.

1997 gründet er das Studio BEATBOX. Taschen, Alltagsgegenstände & Grafik sind die grundlegenden Tätigkeiten, mit denen sich das Studio beschäftigt, das mit bedeutenden italienischen und ausländischen Firmen der Branche zusammenarbeitet und in Frankreich, China und Japan tätig ist.

Seit 2013 betreibt er seine persönliche Beratungstätigkeit für Unternehmen. Eleganz und Ausgewogenheit sind die Grundelemente und inspirierenden Prinzipien seiner Arbeit.

ES Nace en 1967 y después de haber conseguido el diploma de Graphic Designer y Comunicación, Luca Artioli emprende su actividad profesional en estudios de publicidad como ilustrador y creativo freelance. En 1994 es Senior Designer para el proyecto de accesorios para el vestir, ocupándose del diseño del accesorio y del grafismo aplicado al producto.

En 1997 crea el estudio BEATBOX. Bolsos, objetos, grafismo, son la base de las actividades de diseño del estudio, que colabora con destacadas empresas italianas y extranjeras del sector, contando con experiencias laborales en Francia, China y Japón.

Desde 2013 prosigue su actividad personal de asesoramiento a las empresas. Elegancia y equilibrio son los elementos distintivos y los principios inspiradores de su trabajo.

RU Родился в 1967 году, После получения диплома в области графического дизайна и коммуникации, Лука Артиоли начинает свою профессиональную деятельность как фрилансер в качестве иллюстратора и креативного консультанта в рекламных студиях. В 1994 году он является старшим дизайнером по проектированию модных аксессуаров, занимающимся дизайном аксессуаров и графикой, приложенной к продукту.

В 1997 году он основывает студию BEATBOX. Сумки, различные предметы, графика являются основой дизайнерской деятельностью студии, которая сотрудничает с крупными итальянскими и зарубежными компаниями в этом секторе и накапливает опыт работы во Франции, Китае и Японии.

С 2013 года он продолжает свою личную деятельность, предоставляя консультационные услуги компаниям. Элегантность и баланс являются основными элементами и руководящими принципами его работы.

Approval and symbols

Omologazione e simboli
Zulassung und Symbole
Aprobación y símbolos
Одобрение и символы



The appliance conforms to European Community Directives / Apparato conforme alle Direttive della Comunità Europea / Gerät ist konform mit den Richtlinien der Europäischen Gemeinschaft / Aparato conforme con las Directivas Comunitarias Europeas / Прибор соответствует требованиям Директив Европейского Сообщества



Lamp holder suitable for use with LED bulbs / Portalampada adatto all'utilizzo di lampadine a LED / Lampenfassung für den Gebrauch von LED Lampen geeignet / Portalámpara idóneo para utilizar bombillas de LED / Ламповый патрон подходит для использования со светодиодными лампами



The appliance is fitted with basic insulation / L'apparecchio è dotato di isolamento di base / Gerät ist mit der Basisisolierung ausgestattet / Aparato dotado de aislamiento básico / Прибор снабжен главной изоляцией



Suited for assembly on flammable surfaces / Apparato idoneo per essere installato su superfici infiammabili / Geeignet für die montage auf entflammaren oberflächen / Adecuado para montaje en superficies inflamables / Прибор годен для установки на пожароопасных поверхностях



The appliance is fitted with double insulation / Apparato dotato di doppio isolamento / Gerät ist mit zwei Isolierungen ausgestattet / Aparato dotado de doble aislamiento / Прибор снабжен двойной изоляцией



Very low voltage / Bassissima tensione / Niederwolt / Muy baja tensión / низковольтные



Unit equipped with LED module / Apparecchio dotato di modulo LED / Gerät mit LED Modul / Aparato con módulo LED / Прибор снабжен светодиодным модулем



Equipment that should not be covered with heat insulating material / Apparecchi non idonei ad essere ricoperti di materiale termicamente isolante / Die Geräte sind nicht dazu geeignet, mit einem / Thermisch isolierenden Material bedeckt zu werden / Aparatos no idóneos para ser tapados con material térmicamente aislante / Устройства не пригодны для покрытия теплоизоляционным материалом

IP2X = IPX0 =

Enclosure protected from solid objects greater than 12 mm in size and the insertion of fingers; no water protection / Involucro protetto contro corpi solidi di dimensioni superiori a 12mm e contro l'accesso con un dito; nessuna protezione contro l'acqua / Gehäuse ist geschützt gegen feste Körper, die größer als 12 mm sind und gegen das Eindringen mit dem Finger; kein Schutz gegen Wasser / Envoltura protegida contra cuerpos sólidos de tamaño superior a 12mm y que impide el acceso con un dedo; ninguna protección contra el agua / оболочка устройства защищена от попадания предметов, диаметр которых больше 12 мм, и от доступа пальцем; нет защиты от проникновения внутрь корпуса воды



DIRECTIVE 2002/96/EC: Obligation not to dispose of WEEE (waste electrical electronic equipment) as mixed municipal waste, but arrange for it to be disposed of separately or returned to the supplier.

DIRETTIVA 2002/96/CEE: L'obbligo di non smaltire i RAEE (rifiuti apparecchiature elettriche elettroniche) come rifiuto municipale misto ma effettuare una raccolta separata o consegnato al produttore.

DIRECTIVE 2002/96/EC: Obligation not to dispose of WEEE (waste electrical electronic equipment) as mixed municipal waste, but arrange for it to be disposed of separately or returned to the supplier.

RICHTLINIE 2002/96/EWG: Elektronikschratt, darf nicht mit dem Hausmüll entsorgt werden, sondern ist getrennt zu sammeln oder an den Hersteller zurückzugeben.

DIRETTIVA 2002/96/CEE: Obligación de no eliminar los RAEE (Residuos de Aparatos Eléctricos y Electrónicos) como basura común sino efectuando una recogida selectiva o entregándolos al fabricante.

ДИРЕКТИВА 2002/96/СЕЕ: Отходы электрического и электронного боруования должны обязательно утилизироваться отдельно от общих бытовых отходов или возвращаться производителю.

Lumen

Unit of measurement of luminous flux / Unità di misura del flusso luminoso / Maßeinheit des Lichtstroms / Unidad de medida del flujo luminoso / Единица измерения светового потока

mA

Electric current intensity / Intensità di corrente elettrica / Intensität des elektrischen Stroms / Intensidad de corriente eléctrica / Сила электрического тока

°K

KELVIN DEGREES - Unit of temperature measurement / GRADI KELVIN - Unità di misura della temperatura di colore / GRAD KELVIN - Maßeinheit der Farbtemperatur / GRADOS KELVIN - Unidad de medida de la temperatura de color / ГРАДУСЫ КЕЛЬВИНА GRADI KELVIN – единица измерения цветовой температуры

2700°K

3000°K

3500°K

4000°K

4500°K

WARM - CALDO - WARM - CALIENTE - ТЕПЛЫЙ СВЕТ

COLD - FREDDO - KALT - FRÍO - ХОЛОДНЫЙ СВЕТ



Suspension lamp / Lampada a sospensione / Pendelleuchte / Lámpara de techo / подвесная лампа



Recessed spotlight / Faretto a incasso / Einbaustrahler / Focos empotrados / встраиваемые точечные светильники



Semi-recessed spotlight / Faretto a semi-incasso / Halbeinbaustrahler / Foco semiencastado / Полувстраиваемый точечный светильник



Ceiling light / Plafoniera / Deckenleuchte / Lámpara de techo / Потолочный светильник



Wall light / Applique / Applikationen / Apliques / Анпликация















Floor light / Lampada da terra / Bodenlampe / Lámpara de tierra / Наземная лампа

Index by type

Indice per tipologia
Index nach Typ
Índice por tipo
Индекс по типу

LED extruded range

Estrusi LED
Stranggepresst mit LED
Extrudidos LED
Светодиодные экструдированные светильники

	Chalcis esterno aluminium T220.AL	p. 52
	Chalcis esterno white T220.W	p. 52
	Emathia incasso aluminium T133.AL	p. 38
	Emathia incasso white T133.W	p. 38
	Eubea esterno aluminium T145.AL	p. 43
	Eubea esterno white T145.W	p. 43
	Eubea incasso aluminium T139.AL	p. 43
	Eubea incasso white T139.W	p. 43
	Icus esterno aluminium T310.AL	p. 62
	Methoni esterno aluminium T309.AL	p. 58
	Oropus incasso aluminium T221.AL	p. 48
	Oropus incasso white T221.W	p. 48















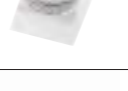



Linear profiles

Profili Lineari
Lineare Profile
Perfiles lineales
Линейные профили

	Pirgos T311.10 / T311.11	p. 70-71
	Pirgos T311.30 / T311.31	p. 72-73
	Pirgos T311.50	p. 74-75

Recessed ceiling range in plaster

Incassi soffitto gesso
Zum Einlassen an der Decke aus Gips
Empotrados techo yeso
Встраиваемые светильники для гипсокартонных потолков



















	Attica T04	p. 148-153		Phocis T384	p. 132
	Attica glass T28			Rhodia T464 / T479 / T465 / T480 / T466 / T481 / T467 / T482	p. 107
	Attica orientabile T177			Rhodia dimmer T468 / T483 / T469 / T484 / T470 / T485 / T471 / T486	p. 112
	Doride T353	p. 136-139		Siris T165	p. 147
	Doride T354			Thessaly T332 / T334 / T335 / T336 / T408 / T409	p. 79
	Elis T418 / T419 / T420 / T421	p. 95		Thessaly Raso T390 / T391 / T392 / T393 / T410 / T411	p. 87
	Elis Raso T414 / T415 / T416 / T417	p. 101			
	Filiatrà T337 / T338	p. 124-131			
	Filiatrà T381 / T382 / T383				
	Heraea T255 / T256 / T257	p. 140			
	Lelanto T356 / T412	p. 118-123			
	Lelanto T357 / T413				

Index by type

Indice per tipologia
Index nach Typ
Índice por tipo
Индекс по типу























Ceiling range in plaster

Gessi soffitto
Gipslampen Decke
Yesos techo
Гипсовые потолочные светильники

	Anchise T371 / T372 / T373	p. 281		Propilei T406 / T487	p. 156-169
	Chio T262 / T263 / T264 / T274 / T278	p. 288		Propilei T407 / T488	
	Cicladi tonda T403 / T404 / T405	p. 236		Sibari T377 / T378	p. 274
	Cicladi T387 / T388 / T389	p. 242		Side T291 / T292 / T293	p. 301
	Demetra T339 / T358 / T359	p. 265		Side small T369	p. 308
	Heraea T193 / T194	p. 314		Syme quadrata T442 / T443 / T444 / T445	p. 190
	Milet T474 / T475 / T476	p. 228		Syme tonda T438 / 439 / T440 / T441	p. 201
	Mysia T454 / T455 / T456	p. 210-227			
	Mysia T457 / T458 / T459				
	Nasso quadrata T426 / T427 / T428 / T429	p. 171			
	Nasso tonda T422 / T423 / T424 / T425	p. 180			
	Pitane T401 / T402	p. 259			



















Wall range in plaster



















Gessi parete
Gipslampen Wand
Yesos pared
Гипсовые настенные светильники

	Anchise T374 / T375	p. 281		Paro T269 / T270	p. 320
	Chio T319 / T320 / T321 / T322	p. 288		Patra T394 / T395	p. 252
	Cicladi T385 / T386 / T396	p. 242		Pellene T200 / T201	p. 334
	Delfi T223	p. 325		Pitane T399 / T400	p. 259
	Demetra T360 / T361 / T362	p. 265		Sibari T379 / T380	p. 274
	Heraea T205	p. 314		Side T326	p. 301
	Hermione T208 / T209 / T210	p. 339		Side small T367 / T368	p. 308
	Milet T472 / T473	p. 228		Syme quadrata T450 / T451 / T452 / T453	p. 190
	Mysia T460 / T461 / T477	p. 210-227		Syme tonda T446 / T447 / T448 / T449	p. 201
	Mysia T462 / T463 / T478			Teos T174.10 / T174.11 / T174.12	p. 328
	Nasso quadrata T434 / T435 / T436 / T437	p. 171			
	Nasso tonda T430 / T431 / T432 / T433	p. 180			

Alphabetical index

Indice alfabetico
Alphabetischer index
Índice alfabético
Алфавитный указатель

	Anchise	T371 / T372 / T373	p. 280-287		Cicladi	T387 / T388 / T389	p. 242-251
	Anchise	T374 / T375			Cicladi tonda	T403 / T404 / T405	p. 236
	Attica	T04	p. 148-153		Delfi	T223	p. 325
	Attica glass	T28			Demetra	T360 / T361 / T362	p. 264-273
	Attica orientabile	T177			Demetra	T339 / T358 / T359	
	Chalcis esterno	T220.al T220.w	p. 52		Doride	T353	p. 136-139
	Chio	T262 / T263 / T264 / T274 / T278	p. 288-299		Doride	T354	
	Chio	T319 / T320 / T321 / T322			Elis	T418 / T419 / T420 / T421	p. 95
	Cicladi	T385 / T386 / T396	p. 242-251		Elis Raso	T414 / T415 / T416 / T417	p. 101

	Emathia incasso	T133.AL T133.W	p. 38		Lelanto	T356 / T412	p. 118-123
	Eubea esterno	T145.AL T145.W	p. 43		Lelanto	T357 / T413	
	Eubea incasso	T139.AL T139.W	p. 43		Methoni esterno	T309.al	p. 58
	Filiatrà	T337 / T338	p. 124-131		Milet	T472 / T473	p. 230
	Filiatrà	T381 / T382 / T383			Milet	T474 / T475 / T476	
	Heraea	T255 / T256 / T257	p. 140		Mysia	T460 / T461 / T477	p. 210-227
	Heraea	T193 / T194 / T205	p. 314		Mysia	T462 / T463 / T478	
	Hermione	T208 / T209 / T210	p. 208		Mysia	T454 / T455 / T456	
	Icus esterno	T310.AL	p. 62		Mysia	T457 / T458 / T459	

Alphabetical index

T

Indice alfabetico
Alphabetischer index
Índice alfabético
Алфавитный указатель

 **Nasso quadrata** T434 / T435 / T436 / T437 **p. 170-179**

 **Nasso quadrata** T426 / T427 / T428 / T429

 **Nasso tonda** T430 / T431 / T432 / T433 **p. 180-189**

 **Nasso tonda** T422 / T423 / T424 / T425

 **Oropus incasso** T221.AL / T221.W **p. 48**

 **Paro** T269 / T270 **p. 320**

 **Patra** T394 / T395 **p. 252**

 **Pellene** T200 / T201 **p. 334**

 **Phocis** T384 **p. 132**

 **Pirgos** T311.10 / T311.11 **p. 68-75**

 **Pirgos** T311.30 / T311.31

 **Pirgos** T311.50

 **Pitane** T399 / T400 **p. 258-263**

 **Pitane** T401 / T402

 **Propilei** T406 / T487 **p. 156-169**

 **Propilei** T407 / T488

 **Rhodia** T464 / T479 / T465 / T480 / T466 / T481 / T467 / T482 **p. 107**

 **Rhodia dimmer** T468 / T483 / T469 / T484 / T470 / T485 / T471 / T486 **p. 112**

 **Sibari** T377 / T378 **p. 274-279**

 **Sibari** T379 / T380

 **Side** T326 **p. 300-307**

 **Side** T291 / T292 / T293

 **Side small** T367 / T368 **p. 308-313**

 **Side small** T369

 **Siris** T165 **p. 147**

 **Syme quadrata** T442 / T443 / T444 / T445 **p. 190-199**

 **Syme quadrata** T450 / T451 / T452 / T453

 **Syme tonda** T438 / 439 / T440 / T441 **p. 200-209**

 **Syme tonda** T446 / T447 / T448 / T449

 **Teos** T174.10 / T174.11 / T174.12 **p. 328**

 **Thessaly** T332 / T334 / T335 / T336 / T408 / T409 **p. 79**

 **Thessaly Raso** T390 / T391 / T392 / T393 / T410 / T411 **p. 87**

Index by code

Indice per codice
Index nach Code
Índice por código
Индекс по коду

T04	Attica	p. 339	T209	Hermione	p. 341
T28	Attica Glass	p. 150	T210	Hermione	p. 342
T73.40W.24.DIM	Alimentatori 40W Dim.	p. 355	T220.AL.	Chalcis Esterno Aluminium	p. 52
T73.100W.24.DIM	Alimentatori 100W Dim.	p. 355	T220.W.	Chalcis Esterno White	p. 52
T73.150W.24.DIM	Alimentatori 150W Dim.	p. 355	T221.AL.	Oropus Incasso Aluminium	p. 48
T73.240W.24.DIM	Alimentatori 240W Dim.	p. 355	T221.W.	Oropus Incasso White	p. 48
T73.320W.24.DIM	Alimentatori 320W Dim.	p. 355	T223	Delfi	p. 324
T73.50W.24.SNP	Alimentatore 50W SNAPPY	p. 355	T255	Heraea	p. 142
T73.100W.24.SNP	Alimentatore 100W SNAPPY	p. 355	T256	Heraea	p. 143
T73.150W.24.SNP	Alimentatore 150W SNAPPY	p. 355	T257	Heraea	p.144
T73.200W.24.SNP	Alimentatore 200W SNAPPY	p. 355	T262	Chio	p. 290
T73.320W.24.SNP	Alimentatore 320W SNAPPY	p. 355	T263	Chio	p. 291
T133	Taglio	p. 354	T264	Chio	p. 292
T133.AL.	Emathia Incasso Aluminium	p. 38	T269	Paro	p. 322
T133.W.	Emathia Incasso White	p. 38	T270	Paro	p. 323
T139.AL.	Eubea Incasso Aluminium	p. 38	T274	Chio	p. 294
T139.W.	Eubea Incasso White	p. 38	T278	Chio	p. 295
T145.AL.	Eubea Esterno Aluminium	p. 38	T291	Side	p. 302
T145.W.	Eubea Esterno White	p. 38	T292	Side	p. 303
T165	Siris	p. 147	T293	Side	p. 304
T174.10	Teos	p. 330	T309.AL.	Methoni Aluminium	p. 58
T174.11	Teos	p. 331	T310.AL.	Icus Esterno Aluminium	p. 62
T174.12	Teos	p. 332	T311.10	Pirgos	p. 70
T177	Attica Orientabile	p. 147	T311.10 D	Pirgos	p. 70
T193	Heraea	p. 316	T311.11	Pirgos	p. 71
T194	Heraea	p. 317	T311.11 D	Pirgos	p. 71
T200	Pellene	p. 336	T311.30	Pirgos	p. 72
T201	Pellene	p. 337	T311.30 D	Pirgos	p. 72
T205	Heraea	p. 218	T311.31	Pirgos	p. 73
T208	Hermione	p. 340	T311.31 D	Pirgos	p. 73

T311.50	Pirgos	p. 74	T377	Sibari	p. 276
T319	Chio	p. 296	T378	Sibari	p. 277
T320	Chio	p. 297	T379	Sibari	p. 278
T321	Chio	p. 298	T380	Sibari	p. 279
T322	Chio	p. 299	T381	Filiatrá	p. 128
T326	Side	p. 306	T382	Filiatrá	p. 129
T332	Thessaly	p. 80	T383	Filiatrá	p. 130
T334	Thessaly	p. 81	T384	Phocis	p. 132
T335	Thessaly	p. 82	T385	Cycladi	p. 244
T336	Thessaly	p. 83	T386	Cycladi	p. 246
T337	Filiatrá	p. 126	T387	Cycladi	p. 248
T338	Filiatrá	p. 127	T388	Cycladi	p. 249
T339	Demetra	p. 267	T389	Cycladi	p. 250
T353	Doride	p. 138	T390	Thessaly	p. 88
T354	Doride	p. 139	T391	Thessaly	p. 89
T356	Lelanto	p. 120	T392	Thessaly	p. 90
T357	Lelanto	p. 121	T393	Thessaly	p. 91
T358	Demetra	p. 268	T394	Patra	p. 254
T359	Demetra	p. 269	T395	Patra	p. 256
T360	Demetra	p. 271	T396	Cycladi	p. 247
T361	Demetra	p. 272	T397.1M.3000	Strip Led 3000°K	p. 354
T362	Demetra	p. 273	T397.2M.3000	Strip Led 3000°K	p. 354
T367	Side small	p. 310	T397.3M.3000	Strip Led 3000°K	p. 354
T368	Side small	p. 311	T397.4M.3000	Strip Led 3000°K	p. 354
T369	Side small	p. 312	T397.5M.3000	Strip Led 3000°K	p. 354
T371	Anchise	p.282	T397.1M.4000	Strip Led 4000°K	p. 354
T372	Anchise	p.283	T397.2M.4000	Strip Led 4000°K	p. 354
T373	Anchise	p.284	T397.3M.4000	Strip Led 4000°K	p. 354
T374	Anchise	p. 286	T397.4M.4000	Strip Led 4000°K	p. 354
T375	Anchise	p. 287	T397.5M.4000	Strip Led 4000°K	p. 354

Index by code

Indice per codice
Index nach Code
Índice por código
Индекс по коду

T398.1M.3000	Strip Led 3000°K	p. 354	T419	Elis	p. 97
T398.2M.3000	Strip Led 3000°K	p. 354	T420	Elis	p. 98
T398.3M.3000	Strip Led 3000°K	p. 354	T421	Elis	p. 99
T398.4M.3000	Strip Led 3000°K	p. 354	T422	Nasso tonda	p. 182
T398.5M.3000	Strip Led 3000°K	p. 354	T423	Nasso tonda	p. 183
T398.1M.4000	Strip Led 4000°K	p. 354	T424	Nasso tonda	p. 184
T398.2M.4000	Strip Led 4000°K	p. 354	T425	Nasso tonda	p. 185
T398.3M.4000	Strip Led 4000°K	p. 354	T426	Nasso quadrata	p. 172
T398.4M.4000	Strip Led 4000°K	p. 354	T427	Nasso quadrata	p. 173
T398.5M.4000	Strip Led 4000°K	p. 354	T428	Nasso quadrata	p. 174
T399	Pitane	p. 260	T429	Nasso quadrata	p. 175
T400	Pitane	p. 261	T430	Nasso tonda	p. 186
T401	Pitane	p. 262	T431	Nasso tonda	p. 187
T402	Pitane	p. 263	T432	Nasso tonda	p. 188
T403	Cicladì tonda	p. 238	T433	Nasso tonda	p. 189
T404	Cicladì tonda	p. 239	T434	Nasso quadrata	p. 176
T405	Cicladì tonda	p. 240	T435	Nasso quadrata	p. 177
T406	Propilei	p. 158	T436	Nasso quadrata	p. 178
T407	Propilei	p. 164	T437	Nasso quadrata	p. 179
T408	Thessaly	p. 84	T438	Syme tonda	p. 202
T409	Thessaly	p. 85	T439	Syme tonda	p. 203
T410	Thessaly	p. 92	T440	Syme tonda	p. 204
T411	Thessaly	p. 93	T441	Syme tonda	p. 205
T412	Lelanto	p. 123	T442	Syme quadrata	p. 192
T413	Lelanto	p. 124	T443	Syme quadrata	p. 193
T414	Elis Raso	p. 102	T444	Syme quadrata	p. 194
T415	Elis Raso	p. 103	T445	Syme quadrata	p. 195
T416	Elis Raso	p. 104	T446	Syme tonda	p. 206
T417	Elis Raso	p. 105	T447	Syme tonda	p. 207
T418	Elis	p. 96	T448	Syme tonda	p. 208

T449	Syme tonda	p. 209	T480	Rhodia	p. 109
T450	Syme quadrata	p. 196	T481	Rhodia	p. 110
T451	Syme quadrata	p. 197	T482	Rhodia	p. 111
T452	Syme quadrata	p. 198	T483	Rhodia	p. 114
T453	Syme quadrata	p. 199	T484	Rhodia	p. 115
T454	Mysia	p. 212	T485	Rhodia	p. 116
T455	Mysia	p. 213	T486	Rhodia	p. 117
T456	Mysia	p. 214	T487	Propilei	p. 162
T457	Mysia	p. 216	T488	Propilei	p. 168
T458	Mysia	p. 217			
T459	Mysia	p. 218			
T460	Mysia	p. 220			
T461	Mysia	p. 221			
T477	Mysia	p. 222			
T462	Mysia	p. 224			
T463	Mysia	p. 225			
T464	Rhodia	p. 108			
T465	Rhodia	p. 109			
T466	Rhodia	p. 110			
T467	Rhodia	p. 111			
T468	Rhodia	p. 114			
T469	Rhodia	p. 115			
T470	Rhodia	p. 116			
T471	Rhodia	p. 117			
T472	Milet	p. 230			
T473	Milet	p. 231			
T474	Milet	p. 232			
T475	Milet	p. 233			
T476	Milet	p. 234			
T479	Rhodia	p. 108			

Index by Designer

Indice per Designer
Index für Designer
Índice para diseñadores
Индекс для дизайнера

Acero design studio

Chio	T262 / T263 / T264 / T274 / T278 T319 / T320 / T321 / T322	p. 288
Heraea	T193 / T194 / T205	p. 314
Heraea	T255 / T256 / T257	p. 140
Hermione	T208 / T209 / T210	p. 339
Mysia	T454 / T455 / T456 / T457 / T458 / T459 T460 / T461 / T462 / T463 / T477 / T478	p. 210
Paro	T269 / T270	p. 320
Side	T323 / T324 / T325 / T326 T291 / T292 / T293	p. 301
Side small	T367 / T368 / T369	p. 308
Teos	T174.10 / T174.11 / T174.12	p. 328

ARTIOLI LUCA

Delfi	T223	p. 324
Pellene	T200 / T201	p. 334

_BLANK DESIGN STUDIO

Anchise	T371 / T372 / T373 T374 / T375	p. 281
Cicladi	T387 / T388 / T389 T385 / T386 / T396	p. 242
Cicladi tonda	T403 / T404 / T405	p. 236
Demetra	T339 / T358 / T359 T360 / T361 / T362	p. 265
Elis	T418 / T419 / T420 / T421	p. 95
Elis Raso	T414 / T415 / T416 / T417	p. 101
Filiatrà	T337 / T338 T381 / T382 / T383	p. 125
Lelanto	T356 / T357 T412 / T413	p. 118
Milet	T472 / T473 / T474 / T475 / T476	p. 228
Nasso quadrata	T426 / T427 / T428 / T429 T434 / T435 / T436 / T437	p. 171
Nasso tonda	T422 / T423 / T424 / T425 T430 / T431 / T432 / T433	p. 180
Patra	T394 / T395	p. 252
Phocis	T384	p. 132
Pitane	T399 / T400 T401 / T402	p. 259
Propilei	T406 / T487 T407 / T488	p. 156

Index by Designer

Indice per Designer
Index für Designer
Índice para diseñadores
Индекс для дизайнера

_BLANK DESIGN STUDIO

Rhodia	T464 / T479 / T465 / T480 / T466 / T481 / T467 / T482	p. 107
Rhodia dimmer	T468 / T483 / T469 / T484 / T470 / T485 / T471 / T486	p. 112
Sibari	T377 / T378 T379 / T380	p. 274
Syme quadrata	T442 / T443 / T444 / T445 T450 / T451 / T452 / T453	p. 190
Syme tonda	T438 / T439 / T440 / T441 T446 / T447 / T448 / T449	p. 201
Thessaly	T332 / T334 / T335 / T336 / T408 / T409	p. 79
Thessaly Raso	T390 / T391 / T392 / T393 / T410 / T410	p. 87

TECNICO R&D

Attica	T04	p. 150
Attica glass	T28	p. 150
Attica orientabile	T177	p. 148
Chalcis esterno aluminium	T220.AL	p. 52
Chalcis esterno white	T220.W	p. 52
Doride	T343 / T354	p. 137

Emathia incasso aluminium	T133.AL	p. 38
Emathia incasso white	T133.W	p. 38
Eubea esterno aluminium	T145.AL	p. 44
Eubea esterno white	T145.W	p. 44
Icus esterno aluminium	T310.AL	p. 62
Methoni esterno aluminium	T309.AL	p. 58
Oropus esterno aluminium	T221.AL	p. 48
Oropus esterno white	T221.W	p. 48
Pirgos	T311.10 / T311.11 T311.30 / T311.31 T311.50	p. 69
Siris	T165	p. 147

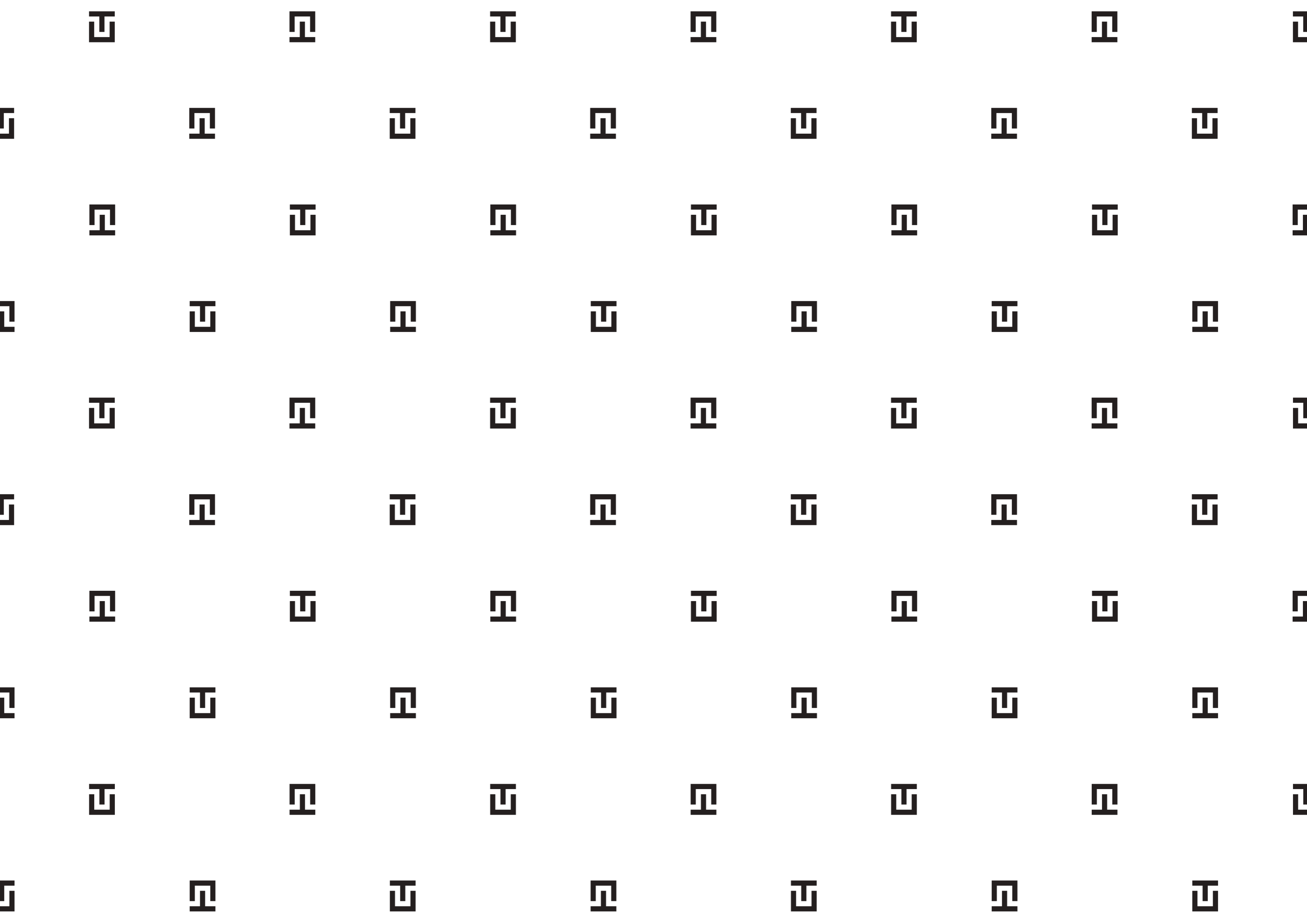

Extruded profiles

Profili estrusi
 Extrudiert Profile
 Extruido perfiles
 Экструдированный профили

Lightweight and durable extruded aluminium products. In natural anodised or white painted aluminium finishes, with opal or satin cover.

IT Prodotti in alluminio estruso, leggeri e durevoli. Nelle finiture alluminio anodizzato naturale o verniciato bianco con copertura opale o satinata.

ES Productos de aluminio extruido ligeros y duraderos. En acabados de aluminio anodizado natural o pintado en blanco con revestimiento opalino o satinado.

DE Leichte und haltbare stranggepresste Aluminiumprodukte. In den Ausführungen Aluminium natur eloxiert oder weiß lackiert mit opaler oder satinierter Abdeckung.

RU Легкие и долговечные изделия из экструдированного алюминия. Покрытие - натуральный анодированный или окрашенный в белый цвет алюминий с опаловой или сатинированной отделкой.

Extruded items

Luci estruse
Extrusi
Extruido
экструдированная продукция

Product name Nome prodotto Produktname Nombre del producto Наименование изделия	Page Pagina Seite Página страница	Measurements Misure Abmessungen Medidas Размеры	Profile Profilo Profil Perfil Профиль
Emathia Incasso T133...	p. 40-41		White Aluminium
Eubea Incasso T139...	p. 44-45		White Aluminium
Oropus Incasso T221...	p. 50-51		White Aluminium
Eubea Esterno T145...	p. 46-47		White Aluminium
Chalcis Esterno T220...	p. 52		White Aluminium
Methoni Esterno T309...	p. 58		Aluminium
Icus Esterno T310...	p. 62		Aluminium

Cover Copertura Abdeckung Recubrimiento Покрытие	LED source / Sorgente LED / LED-Lichtquelle / Fuente de LED / Светодиодный источник света			
	T397...		T398...	
	14,4 Watt/m 3.000 K°	14,4 Watt/m 4.000 K°	19,2 Watt/m 3.000 K°	19,2 Watt/m 4.000 K°
	Ra80 2016 lumen/m 160 LED/m 24V	Ra80 2232 lumen/m 160 LED/m 24V	Ra90 2400 lumen/m 240 LED/m 24V	Ra90 2640 lumen/m 240 LED/m 24V
Satin	✓	✓	✓	✓
Opal	✓	✓	✓	✓
Satin	✓	✓	✓	✓
Opal	✓	✓	✓	✓
Satin	✓	✓	✓	✓
Opal	✓	✓	✓	✓
Opal	✓	✓	✓	✓

Emathia



T133.W / T133.AL

Tecnico R&D

Defined lines to frame any environment. The Emathia lamp - extruded aluminium, with natural anodised or white painted aluminium finish and opal or satin cover - enhances any space, by providing spot-on lighting.

IT Linee definite che incorniciano gli ambienti. La lampada Emathia in estruso di alluminio, con finitura alluminio anodizzato naturale o verniciato bianco e copertura opale o satinata, sottolinea gli spazi garantendo un'illuminazione dedicata per ogni spazio.

ES Líneas definidas que enmarcan los ambientes. La lámpara Emathia de aluminio extruido, con acabado de aluminio anodizado natural o pintado en blanco y revestimiento opalino o satinado, realza los espacios proporcionando una iluminación específica para cada espacio.

DE Definierte Linien, die Räume einrahmen. Die Leuchte Emathia aus stranggepresstem Aluminium, naturfarben eloxiert oder weiß lackiert, mit opaler oder satinierter Abdeckung, unterstreicht Räume, indem sie für jeden Raum eine eigene Beleuchtung bietet.

RU Четкие линии, обрамляющие комнаты. Светильник Emathia из экструдированного алюминия с покрытием натуральный анодированный или окрашенный в белый цвет алюминий и опаловой или сатирированной отделкой, помогает зонировать пространство, обеспечивая необходимое освещение для каждой зоны.

Material / Materiale / Material / Material / Материал

Aluminum and polymeric material / Alluminio e materiale polimerico / Aluminium und Polymermaterial / Aluminio y material polimérico / Алюминий и полимерный материала

Finish / Finitura / Fertigstellen / Terminar / закончить

Aluminum / Alluminio / Aluminium / Aluminio / Алюминий
White / Bianco / Weiß / Blanco / белый

Light source / Fonte di luce / Lichtquelle / Fuente de luz / Источник света

LED Stripe p. 36

Type-approvals / Omologazioni / Zulassungen / Homologaciones / Разрешения



LED strips available / Strisce LED disponibili / LED-Streifen verfügbar / Tiras LED disponibles / в наличии светодиодные ленты





←↓
T133 Emathia
Extruded aluminium system
with opal or satin-finished cover
w62,4 x h34,9 mm
length: 500/1000/1500/2000 mm





Eubea



T139.W / T139.AL
T145.W / T145.AL

Tecnico R&D

An unobtrusive light source. The Eubea system - natural or white painted extruded aluminium, with opal or satin cover - can be installed as recessed or surface mounted, to make any environment elegant-looking.

IT Una delicata sorgente di luce. Eubea, sistema in estruso di alluminio naturale o verniciato bianco con copertura opale o satinata, installabile ad incasso o in appoggio, dona un carattere elegante agli ambienti.

ES Una suave fuente de luz. Eubea, un sistema de aluminio extruido pintado de color natural o blanco con revestimiento opalino o satinado, que puede ir empotrado o en superficie, confiere un carácter elegante a los ambientes.

DE Eine sanfte Lichtquelle. Eubea, ein System aus naturfarbenem oder weiß lackiertem stranggepresstem Aluminium mit einer opalen oder satinierten Abdeckung, das sowohl an der Decke als auch angelehnt installiert werden kann, verleiht den Räumen einen eleganten Charakter.

RU Мягкий источник света. Система Eubea, которая наполняет помещения элегантностью, выполнена из экструдированного алюминия натурального цвета или окрашенного в белый цвет, с опаловой или сатирированной отделкой, и может быть встраиваемой либо накладной.

Material / Materiale / Material / Material / Материал

Aluminum and polymeric material / Alluminio e materiale polimerico / Aluminium und Polymermaterial / Aluminio y material polimérico / Алюминий и полимерный материал

Finish / Finitura / Fertigstellen / Terminar / закончить

Aluminum / Alluminio / Aluminium / Aluminio / Алюминий

White / Bianco / Weiß / Blanco / белый

Light source / Fonte di luce / Lichtquelle / Fuente de luz / Источник света

LED Stripe

p. 36

Type-approvals / Omologazioni / Zulassungen / Homologaciones / Разрешения



LED strips available / Strisce LED disponibili / LED-Streifen verfügbar / Tiras LED disponibles / в наличии светодиодные ленты



↑→
T139 Eubea
 Extruded aluminium system with opal cover
 w35,2 x h34,9 mm
 lenght: 500/1000/1500/2000 mm



↑
T139 Eubea
 Extruded aluminium system with satin-finished cover
 w35,2 x h34,9 mm
 lenght: 500/1000/1500/2000 mm



↓
T145 Eubea
 Extruded aluminium system with satin-finished cover
 w35,2 x h34,9 mm
 lenght: 500/1000/1500/2000 mm



← ↑
T145 Eubea
 Extruded aluminium system with opal cover
 w35,2 x h34,9 mm
 lenght: 500/1000/1500/2000 mm



Oropus



T221.W / T221.AL

Tecnico R&D

An essential, architecture-defining line. The Oropus system - natural or white painted extruded aluminium with opal or satin cover - can be installed as recessed on the ceiling or wall, to highlight specific details and create a minimalistic atmosphere.

IT Linea essenziale che definisce l'architettura. Il sistema in estruso di alluminio naturale o verniciato bianco con copertura opale o satinata Oropus, installabile ad incasso a soffitto o parete, evidenzia i dettagli creando atmosfere essenziali.

ES Línea esencial que define la arquitectura. El sistema Oropus de aluminio extruido pintado en blanco o natural con revestimiento opalino o satinado, que puede instalarse empotrado en el techo o en la pared, realza los detalles creando atmósferas esenciales.

DE Wesentliche Linie, die die Architektur definiert. Das System Oropus aus naturfarbenem oder weiß lackiertem stranggepresstem Aluminium mit opaler oder satinierter Abdeckung, das flächenbündig an der Decke oder an der Wand installiert werden kann, hebt die Details hervor, indem es wesentliche Atmosphären schafft.

RU Минималистичная линия, подчеркивающая архитектуру интерьера. Система Oropus, которая изящно подчеркивает детали, создавая сдержанно-благородную атмосферу, выполнена из экструдированного алюминия натурального цвета или окрашенного в белый цвет, с опаловой или сатиновой отделкой, и встраивается в потолок либо в стену.

Material / Materiale / Material / Material / Материал

Aluminum and polymeric material / Alluminio e materiale polimerico / Aluminium und Polymermaterial / Aluminio y material polimérico / Алюминий и полимерный материал

Finish / Finitura / Fertigstellen / Terminar / закончить

Aluminum / Alluminio / Aluminium / Aluminio / Алюминий

White / Bianco / Weiß / Blanco / белый

Light source / Fonte di luce / Lichtquelle / Fuente de luz / Источник света

LED Stripe p. 36

Type-approvals / Omologazioni / Zulassungen / Homologaciones / Разрешения



LED strips available / Strisce LED disponibili / LED-Streifen verfügbar / Tiras LED disponibles / в наличии светодиодные ленты

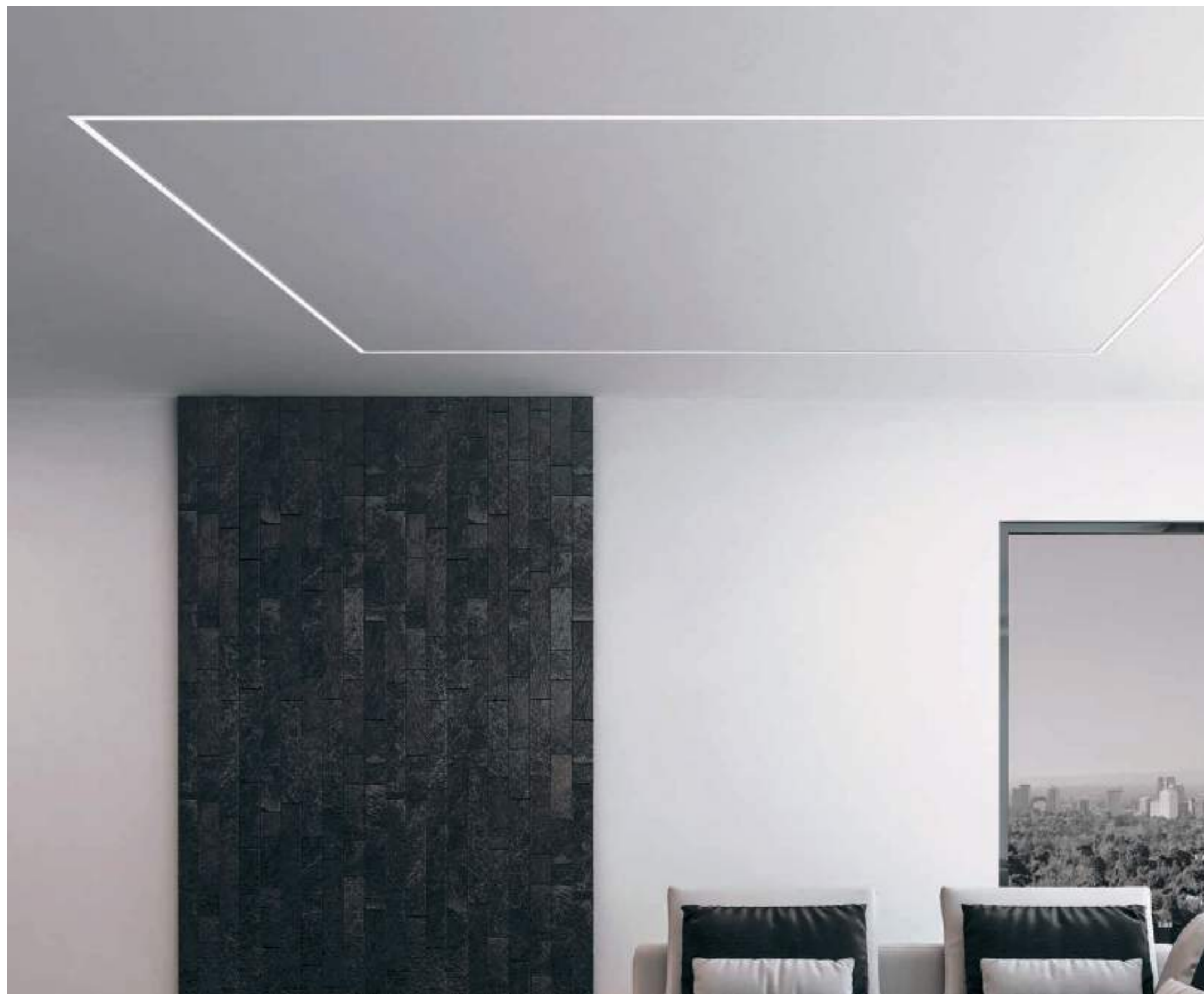



←↓
T221 Oropus
 Extruded aluminium system with opal cover
 w25 x h18,5 mm
 length: 500/1000/1500/2000 mm

↑→
T221 Oropus
 Extruded aluminium system with opal cover
 w25 x h18,5 mm
 length: 500/1000/1500/2000 mm



Chalcis



T220.W / T220.AL

Tecnico R&D

Clean aesthetics and formal details. The Chalcis system - natural or white painted extruded aluminium with opal or satin cover - can be installed on the ceiling or wall, and it blends into any environment elegantly, highlighting the space.

IT Pulizia estetica e dettagli formali. Il sistema Chalcis in estruso di alluminio naturale o verniciato bianco e copertura opale o satinata, installabile a soffitto o parete, si integra con eleganza negli ambienti disegnando gli spazi.

ES Limpieza estética y detalles formales. El sistema Chalcis de aluminio extruido pintado en blanco o natural y revestimiento opalino o satinado, que puede instalarse en el techo o en la pared, se integra con elegancia en los ambientes, diseñando espacios.

DE Ästhetische Sauberkeit und formale Details. Das System Chalcis aus stranggepresstem Aluminium, naturfarben oder weiß lackiert, mit opaler oder satiniertes Abdeckung, das an der Decke oder an der Wand installiert werden kann, fügt sich elegant in die Räume ein und gestaltet sie.

RU Эстетическая чистота и строгие детали. Система Chalcis, которая элегантно вписывается в интерьеры, зонирова пространство, выполнена из экструдированного алюминия натурального цвета или окрашенного в белый цвет, с опаловой или сатирированной отделкой, и может устанавливаться на потолок либо на стену.

Material / Materiale / Material / Material / Материал

Aluminum and polymeric material / Alluminio e materiale polimerico / Aluminium und Polymermaterial / Aluminio y material polimérico / Алюминий и полимерный материала

Finish / Finitura / Fertigstellen / Terminar / закончить

Aluminum / Alluminio / Aluminium / Aluminio / Алюминий

White / Bianco / Weiß / Blanco / белый

Light source / Fonte di luce / Lichtquelle / Fuente de luz / Источник света

LED Stripe p. 36

Type-approvals / Omologazioni / Zulassungen / Homologaciones / Разрешения



LED strips available / Strisce LED disponibili / LED-Streifen verfügbar / Tiras LED disponibles / в наличии светодиодные ленты



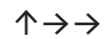

T220 Chalcis

Extruded aluminium system with opal cover
 W17,5 x h15 mm
 length: 500/1000/1500/2000 mm





←
T220 Chalcis
Extruded aluminium system with opal cover
w17,5 x h15 mm
length: 500/1000/1500/2000 mm

Methoni



T309.AL

Tecnico R&D

Compositional flexibility. The Methoni extruded aluminium lamp can be used to create personalized and easy-to-install light compositions. Methoni can be installed on the ceiling or wall.

IT Flessibilità compositiva. La lampada in estruso d'alluminio Methoni permette di creare composizioni di luce grazie alla semplicità di installazione. Methoni può essere installata a soffitto o a parete.

ES Flexibilidad compositiva. La lámpara Methoni de aluminio extruido permite crear composiciones luminosas gracias a su sencilla instalación. Methoni puede instalarse en el techo o en la pared.

DE Kompositorische Flexibilität. Die Leuchte Methoni aus stranggepresstem Aluminium ermöglicht dank ihrer einfachen Installation die Schaffung von Lichtkompositionen. Methoni kann an der Decke oder an der Wand installiert werden.

RU Композиционная гибкость. Благодаря простой установке светильник Methoni, выполненный из экструдированного алюминия, позволяет создавать световые композиции. Methoni может устанавливаться на потолок или на стену.

Material / Materiale / Material / Material / Material / Material

Aluminum and polymeric material / Alluminio e materiale polimerico / Aluminium und Polymermaterial / Aluminio y material polimérico / Алюминий и полимерный материала

Finish / Finitura / Fertigstellen / Terminar / закончить

Aluminum / Alluminio / Aluminium / Aluminio / Алюминий

Light source / Fonte di luce / Lichtquelle / Fuente de luz / Источник света

LED Stripe

p. 36

Type-approvals / Omologazioni / Zulassungen / Homologaciones / Разрешения



LED strips available / Strisce LED disponibili / LED-Streifen verfügbar / Tiras LED disponibles / в наличии светодиодные ленты





T309 Methoni

Extruded aluminium system with opal cover
w19,4 x h20 mm
length: 500/1000/1500/2000 mm

Icus



T310.AL

Tecnico R&D

Compact, minimalist style. The Icus system is made of extruded or white painted aluminium, with opal or satin cover. With its refined look and ceiling- or wall-mounting options, it follows the architectural lines, turning them into luminous elements.

IT Stile compatto e minimale. Icus è un sistema in estruso di alluminio o alluminio verniciato bianco con copertura opale o satinata. Con la sua raffinata presenza e la possibilità di installazione a soffitto o parete, segue le linee architettoniche trasformandole in elementi luminosi.

ES Estilo compacto y minimalista. Icus es un sistema de aluminio extruido o aluminio pintado de blanco con revestimiento opalino o satinado. Con su refinada presencia y la posibilidad de instalación en techo o pared, sigue las líneas arquitectónicas, transformándolas en elementos luminosos.

DE Kompakter, minimalistischer Stil. Icus ist ein System aus stranggepresstem oder weiß lackiertem Aluminium mit einer opalen oder satinierten Abdeckung. Mit ihrer raffinierten Präsenz und der Möglichkeit, sie an der Decke oder an der Wand zu installieren, folgt sie den architektonischen Linien und verwandelt sie in leuchtende Elemente.

RU Компактный и минималистичный стиль. Icus - это система из экструдированного алюминия или алюминия, окрашенного в белый цвет, с опаловым или сатиновым покрытием. Благодаря изысканному дизайну и возможности установки на потолок либо на стену светильник воспроизводит архитектурные линии, превращая их в элементы освещения.

Material / Materiale / Material / Material / Материал

Aluminum and polymeric material / Alluminio e materiale polimerico / Aluminium und Polymermaterial / Aluminio y material polimérico / Алюминий и полимерный материал

Finish / Finitura / Fertigstellen / Terminar / закончить

Aluminum / Alluminio / Aluminium / Aluminio / Алюминий

Light source / Fonte di luce / Lichtquelle / Fuente de luz / Источник света

LED Stripe p. 36

Type-approvals / Omologazioni / Zulassungen / Homologaciones / Разрешения



LED strips available / Strisce LED disponibili / LED-Streifen verfügbar / Tiras LED disponibles / в наличии светодиодные ленты





↑→
T310 Icus
Extruded aluminium system with opal cover
w17,5 x h7 mm
length: 500/1000/1500/2000 mm





Linear profiles

Profili lineari
Lineare profile
Perfiles lineales
Линейные контуры

Linear lighting elements with an extruded aluminium structure, opal cover and perfect light diffusion. The collection includes ceiling- and wall-mounted, pendant and floor products.

IT elementi di illuminazione lineari con struttura in alluminio estruso e copertura opale e una perfetta diffusione della luce. Nella collezione sono presenti prodotti installabili a soffitto, a parete, a sospensione o piantane da terra.

ES Elementos de iluminación lineales con estructura de aluminio extruido y revestimiento opalino y una perfecta difusión de la luz. En la colección hay productos que pueden instalarse en el techo, en la pared, colgantes o de pie.

DE Lineare Beleuchtungselemente mit einer Struktur aus stranggepresstem Aluminium mit opaler Abdeckung und perfekter Lichtstreuung. In der Kollektion gibt es Produkte, die an der Decke, an der Wand, als Pendelleuchte oder als Standleuchte installiert werden können.

RU линейные световые элементы с корпусом, выполненным из экструдированного алюминия с опаловой отделкой, которые обеспечивают идеальное рассеивание света. В коллекции представлены изделия, которые могут устанавливаться на потолок и на стену, подвесные или напольные.



Pirgos



T311.10 / T311.11
T311.30 / T311.31
T311.50

Tecnico R&D

Illuminating with delicate refinement. Pirgos extruded aluminium structure embraces the light diffused by the opal cover, creating an enveloping atmosphere. Available in the ceiling, wall, pendant or floor versions, Pirgos is a versatile collection that allows coordinating different lighting solutions in the same or different rooms.

IT Illuminare con delicata raffinatezza. La struttura in alluminio estruso di Pirgos abbraccia la luce diffusa dalla copertura opale, creando un'atmosfera avvolgente. In versione soffitto, parete, sospensione o piantana, Pirgos è una collezione versatile che permette di coordinare diverse soluzioni di illuminazione sia nello stesso ambiente che in ambienti diversi.

ES Iluminar con una delicada elegancia. La estructura de aluminio extruido de Pirgos abraza la luz difundida por el revestimiento opalino, creando una atmósfera envolvente. En versiones de techo, pared, colgante o de pie, Pirgos es una colección versátil que permite coordinar diferentes soluciones de iluminación en el mismo ambiente o en ambientes diferentes.

DE Beleuchten mit zarter Raffinesse. Die Struktur von Pirgos aus stranggepresstem Aluminium umschließt das von der opalen Abdeckung gestreute Licht und schafft eine einhüllende Atmosphäre. Ob als Decken-, Wand-, Pendel- oder Stehleuchte, Pirgos ist eine vielseitige Kollektion, die es ermöglicht, verschiedene Beleuchtungslösungen im gleichen oder in verschiedenen Räumen zu koordinieren.

RU Освещение под знаком изящной элегантности. Корпус светильника Pirgos, выполненный из экструдированного алюминия с опаловой отделкой, дарит рассеянный свет, создавая обволакивающую атмосферу. Потолочные, настенные, подвесные или напольные светильники Pirgos - это универсальная коллекция, позволяющая сочетать различные световые решения в одном или разных помещениях.

Material / Materiale / Material /
Material / Материал

Aluminum and polymeric material / Alluminio e materiale polimerico / Aluminium und Polymermaterial / Aluminio y material polimérico / Алюминий и полимерный материал

Light source / Fonte di luce /
Lichtquelle / Fuente de luz /
Источник света

LED Stripe

Type-approvals / Omologazioni /
Zulassungen / Homologaciones /
Разрешения

CE  IP40 T311.10
T311.11
T311.30
T311.31

CE  IP40 T311.50



↓
T311.10 Pirgos
 Opal polymeric wall/ceiling lamp.
 Grey painted metal base with built-in power supply
 LED stripe 19,2W
 Ø60 x 1000 mm



← ↑
T311.11 Pirgos
 Opal polymeric wall/ceiling lamp.
 Grey painted metal base with built-in power supply
 LED stripe 38,4W
 Ø60 x 2000 mm



↑ →

T311.30 / T311.31 Pirgos

Opal polymeric suspension lamp.
 Grey painted metal canopy with built-in power supply.
 Power cable height: 200 cm
 LED stripe 19,2 / 38,4W
 Ø60 x 1000/2000 mm





↑↑→

T311.50 Pirgos

Opal polymeric floor lamp with
Grey painted metal base with built-in dimmable power supply
LED stripe 38,4W
Ø300 x 2000 mm



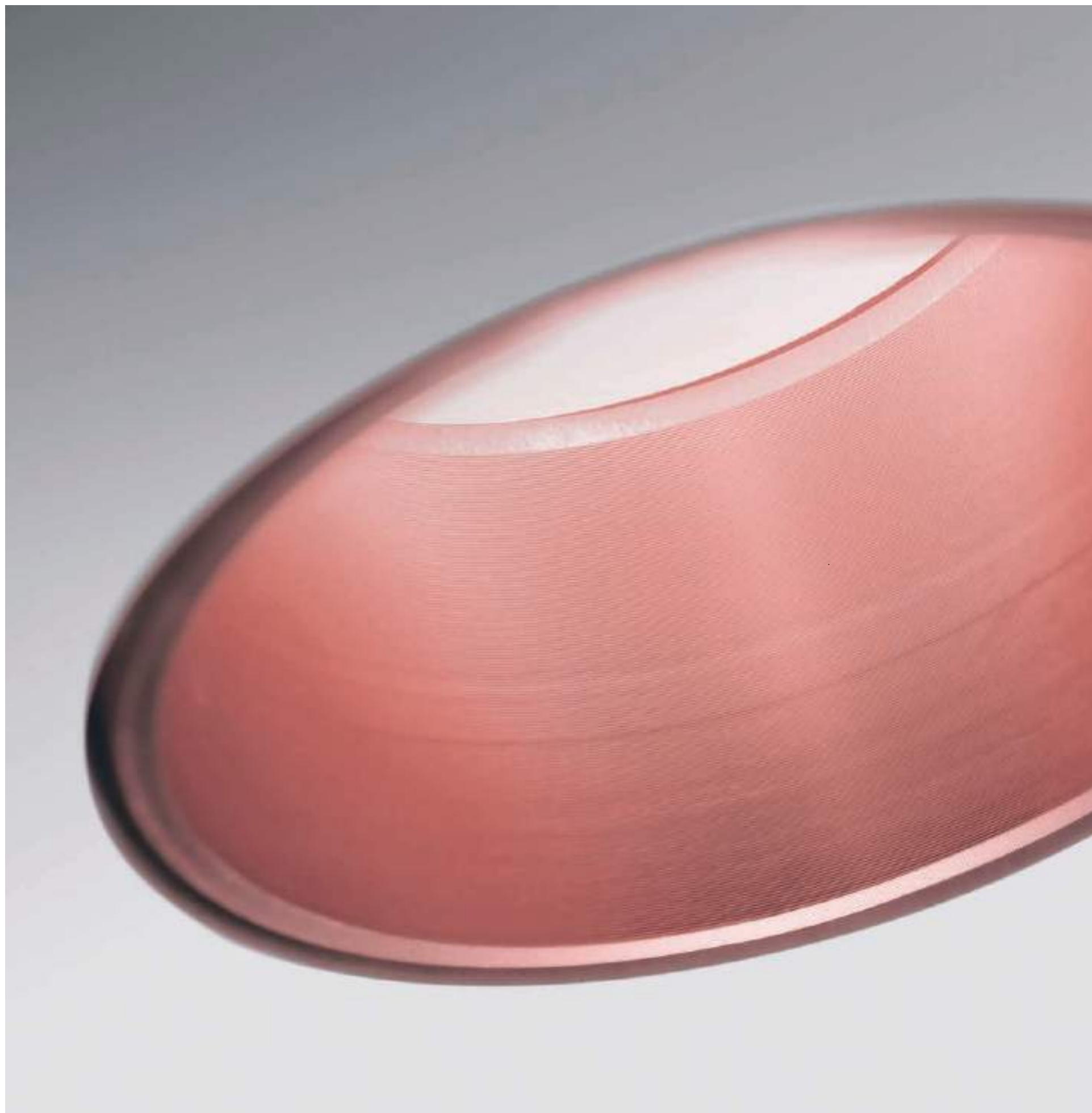

Recessed plaster ceiling lighting

Lampade da incasso in gesso
 Einbau aus gips an der decke
 Empotrables de yeso para techo
 Встраиваемые потолочные светильники из гипса

Series of fully or partially concealed recessed plaster lighting solutions, for plasterboard false ceilings or walls. Designed to create evocative and discreet applications.

IT Serie di apparecchi da incasso in gesso a scomparsa totale o parziale per controsoffitti o pareti in cartongesso. Nati per soddisfare le esigenze di applicazioni suggestive e discrete.

ES Serie de luminarias empotrables de yeso, total o parcialmente ocultas, para falsos techos o paredes de pladur. Creados para satisfacer las necesidades de aplicaciones llamativas y discretas.

DE Serie von vollständig oder teilweise verdeckten Gipskartoneinbauleuchten für Zwischendecken oder Gipskartonwände. Geschaffen, um den Anforderungen von auffälligen und diskreten Anwendungen gerecht zu werden.

RU Линейка полностью или частично встраиваемых гипсовых светильников для подвесных потолков или стен из гипсокартона. Для эффектных и элегантных вариантов освещения.



Thessaly



T332 / T334 / T335 / T336 / T408 / T409

_blank design studio

Elegance embedded in architecture. Thessaly is a single-light recessed plaster lamp. It features an embossed round aluminum frame, available in six different finishes.

IT Eleganza incastonata nell'architettura. Thessaly, lampada a incasso per cartongesso ad una luce, si caratterizza per una cornice in alluminio circolare in rilievo, disponibile in sei diverse finiture.

ES Elegancia incrustada en la arquitectura. Thessaly, una lámpara empotrada de una luz para paredes de pladur, se caracteriza por un marco de aluminio circular en relieve y está disponible en seis acabados diferentes.

DE Eleganz in Architektur eingebettet. Thessaly, eine einflammige Einbauleuchte aus Gips, zeichnet sich durch einen runden Aluminiumrahmen mit Relief aus, der in sechs verschiedenen Ausführungen erhältlich ist.

RU Элегантность, слитая с интерьером. Встраиваемый светильник Thessaly с одним источником света, предназначенный для гипсокартона, комплектуется рельефной круглой алюминиевой рамкой с шестью вариантами отделки.

Material / Materiale / Material / Material / Material / Материал

Plaster and aluminium / Gesso e alluminio / Gips und Aluminium / Yeso y aluminio / Гипс и алюминий

Finish / Finitura / Fertigstellen / Terminar / закончить

Matte black / Nero opaco / Mattschwarz / Negro mate / матовый черный

Matte white / Bianco opaco / Matt Weiß / Blanco Mate / Мэтт Уайт

Brushed brass / Ottone spazzolato / Gebürstetes Messing / Latón cepillado / Матовая латунь

Brushed copper / Rame spazzolato / Gebürstetes Kupfer / Cobre cepillado / Матовая медь

Brushed aluminium / Alluminio spazzolato / Gebürstetes Aluminium / Aluminio cepillado / Матовый алюминий

Brushed bronze / Bronzo spazzolato / Gebürstete Bronze / Bronce cepillado / Матовая бронза

Light source / Fonte di luce / Lichtquelle / Fuente de luz / Источник света

GU10 x 40W

Type-approvals / Omologazioni / Zulassungen / Homologaciones / Разрешения



Ø 100 mm - Recommended installation hole
 Ø 100 mm - Foro per installazione suggerito
 Ø 100 mm - Empfohlene Einbauöffnung
 Ø 100 mm - Orificio para instalación aconsejado
 Ø 100 mm - Рекомендуемое установочное отверстие

Once installed in the plasterboard, it is flush with the ceiling and it can be painted over.
 Dopo averlo installato nel cartongesso risulta parte integrante del soffitto e può essere tinteggiato.
 Nach dem Einbau in Gipskartonplatten ist es ein integraler Bestandteil der Decke und kann gestrichen werden.
 Tras su instalación en pladur, forma parte integrante del techo y puede pintarse.
 После установки в гипсокартон становится составной частью потолка и может быть окрашен.



T332 Thessaly
 Recessed plaster spotlight
 with matte black painted ring finishing
 GU10 – 1x40W
 Ø60 mm aluminium ring



T334 Thessaly
 Recessed plaster spotlight
 with matte white painted ring finishing
 GU10 – 1x40W
 Ø60 mm aluminium ring





↓ →
T335 Thessaly
 Recessed plaster spotlight
 with brushed brass ring finishing
 GU10 – 1x40W
 Ø60 mm aluminium ring



← ↑
T336 Thessaly
 Recessed plaster spotlight
 with brushed copper ring finishing
 GU10 – 1x40W
 Ø60 mm aluminium ring



↓ → →
T408 Thessaly
 Recessed plaster spotlight
 with brushed aluminium ring finishing
 GU10 – 1x40W
 Ø60 mm aluminium ring



← ↑
T409 Thessaly
 Recessed plaster spotlight
 with brushed bronze ring finishing
 GU10 – 1x40W
 Ø60 mm aluminium ring

Recessed lights



Thessaly Raso

T390 / T391 / T392 / T393 / T410 / T411

_blank design studio

The union between light and the environment. In the Thessaly “flush” version - single recessed light for plasterboard - the only visible part is the aluminium edge flush with the wall, available in six different colours.

IT L'unione tra luce e ambiente. Nella versione “raso” di Thessaly, lampada a incasso per cartongesso ad una luce, l'unico elemento visibile è il bordo in alluminio a filomuro proposto in sei varianti cromatiche.

ES La unión entre luz y ambiente. En esta versión empotrable de Thessaly para pladur de una sola luz, el único elemento visible es el borde de aluminio raso que se propone en seis colores.

DE Die Verbindung von Licht und Ambiente. Bei der Version “Raso” von Thessaly, einer einflammigen Einbauleuchte aus Gipskarton, ist das einzige sichtbare Element der in sechs Farbvarianten angebotene Aluminium-Einbaurand.

RU Гармоничный союз света и интерьера. В версии “заподлицо” встраиваемого точечного светильника Thessaly с одним источником света, предназначенного для гипсокартона, единственным видимым элементом является алюминиевая окантовка, которая устанавливается вровень с поверхностью и предлагается в шести цветовых вариантах.

Material / Materiale / Material / Material / Материал

Plaster and aluminium / Gesso e alluminio / Gips und Aluminium / Yeso y aluminio / Гипс и алюминий

Finish / Finitura / Fertigstellen / Terminar / закончить

Matte black / Nero opaco / Mattschwarz / Negro mate / матовый черный

Matte white / Bianco opaco / Mattweiß / Blanco Mate / Мэтт Уайт

Brushed brass / Ottone spazzolato / Gebürstetes Messing / Latón cepillado / Матовая латунь

Brushed copper / Rame spazzolato / Gebürstetes Kupfer / Cobre cepillado / Матовая медь

Brushed aluminium / Alluminio spazzolato / Gebürstetes Aluminium / Aluminio cepillado / Матовый алюминий

Brushed bronze / Bronzo spazzolato / Gebürstete Bronze / Bronce cepillado / Матовая бронза

Light source / Fonte di luce / Lichtquelle / Fuente de luz / Источник света

GU10 x 40W

Type-approvals / Omologazioni / Zulassungen / Homologaciones / Разрешения



Ø 100 mm - Recommended installation hole
 Ø 100 mm - Foro per installazione suggerito
 Ø 100 mm - Empfohlene Einbauöffnung
 Ø 100 mm - Orificio para instalación aconsejado
 Ø 100 mm - Рекомендуемое установочное отверстие

Once installed in the plasterboard, it is flush with the ceiling and it can be painted over.
 Dopo averlo installato nel cartongesso risulta parte integrante del soffitto e può essere tinteggiato.
 Nach dem Einbau in Gipskartonplatten ist es ein integraler Bestandteil der Decke und kann gestrichen werden.
 Tras su instalación en pladur, forma parte integrante del techo y puede pintarse.
 После установки в гипсокартон становится составной частью потолка и может быть окрашен



↓→→
T390 Thessaly Raso
 Flush recessed plaster spotlight
 with matte black painted ring finishing
 GU10 – 1x40W
 Ø60 mm aluminium ring

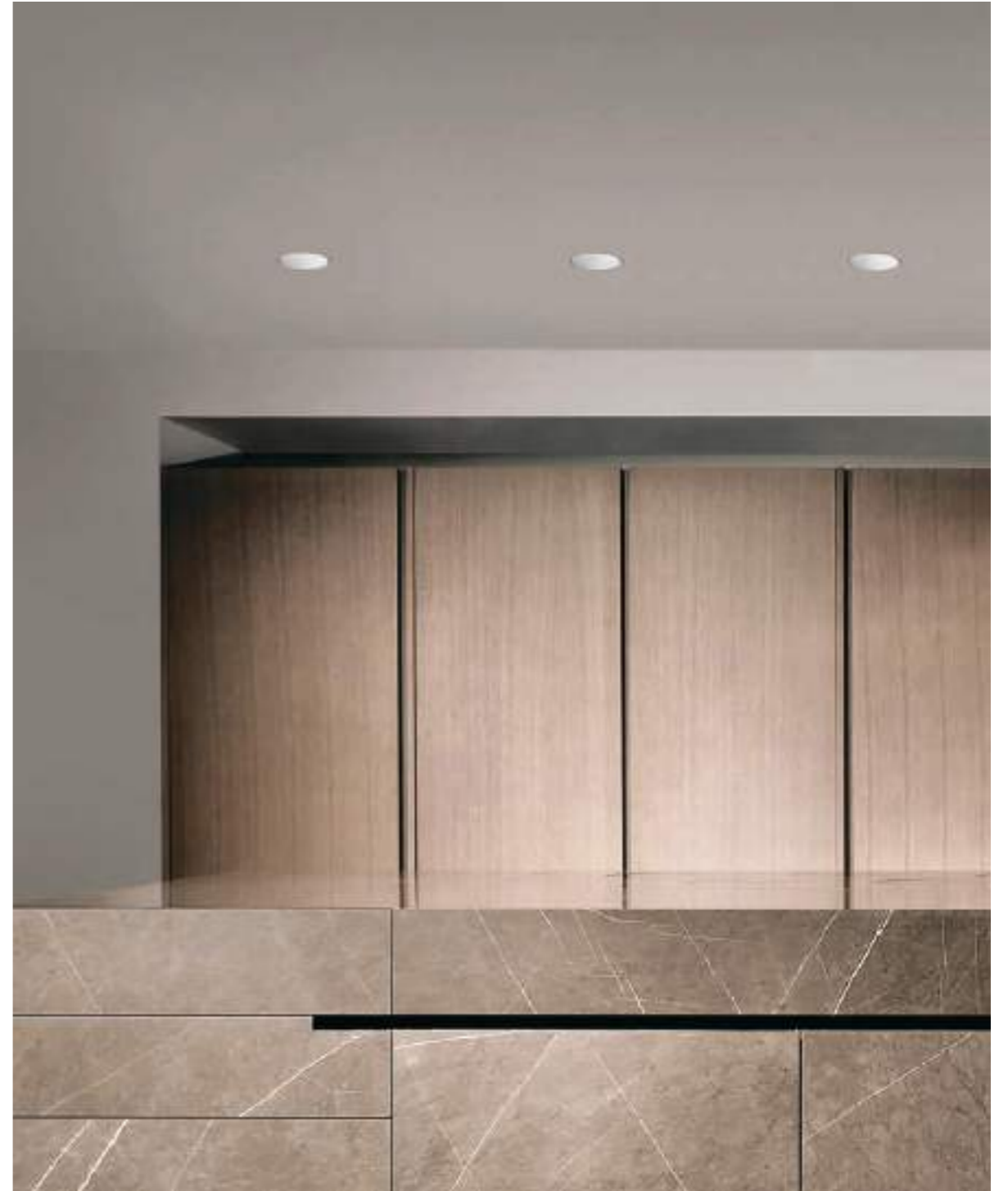

←↑
391 Thessaly Raso
 Flush recessed plaster spotlight
 with matte white painted ring finishing
 GU10 – 1x40W
 Ø60 mm aluminium ring

Recessed lights



↑↑→

T392 Thessaly Raso

Flush recessed plaster spotlight
with brushed brass ring finishing
GU10 – 1x40W
Ø60 mm aluminium ring

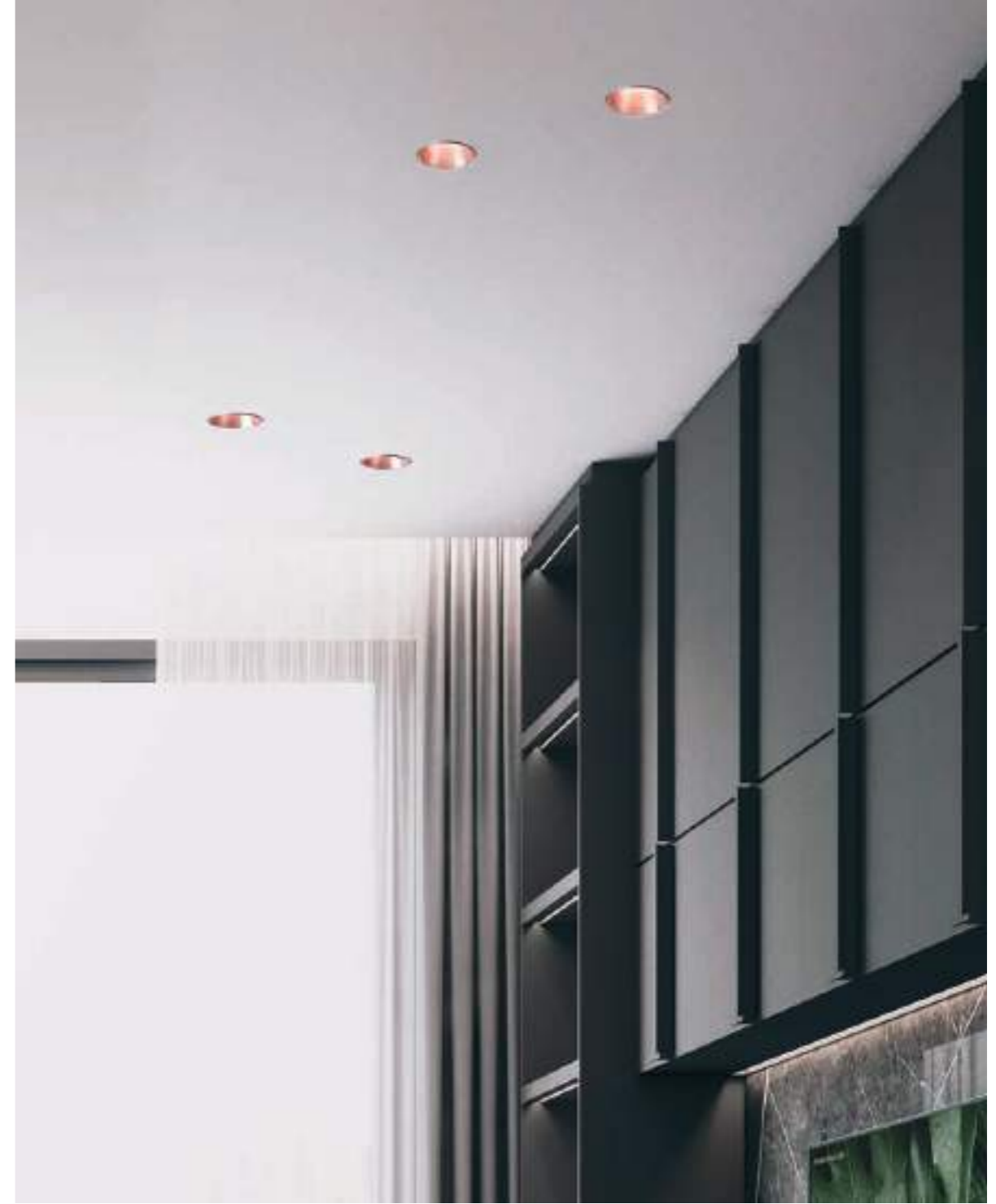

←↑

T393 Thessaly Raso

Flush recessed plaster spotlight
with brushed copper ring finishing
GU10 – 1x40W
Ø60 mm aluminium ring

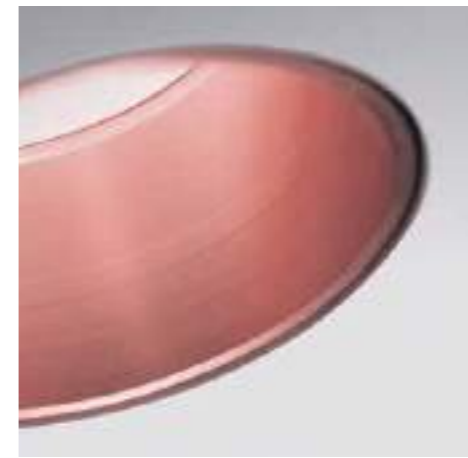

Recessed lights

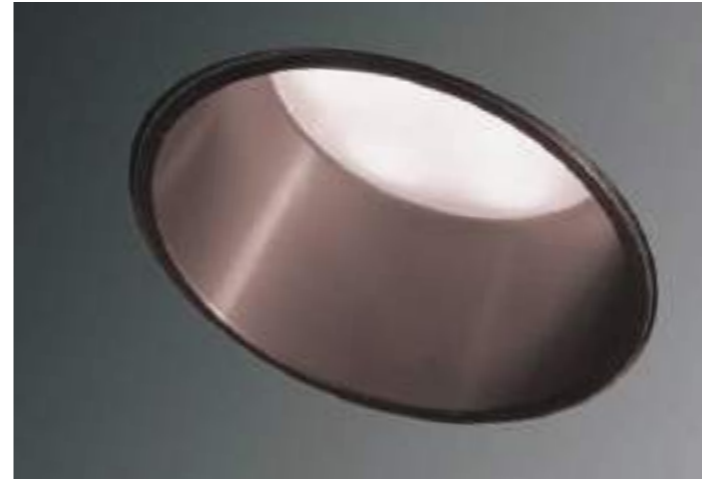

← ↓
T411 Thessaly Raso
 Flush recessed plaster spotlight
 with brushed bronze ring finishing
 GU10 - 1x40W
 Ø60 mm aluminium ring



↑ →
T410 Thessaly Raso
 Flush recessed plaster spotlight
 with brushed aluminium ring finishing
 GU10 - 1x40W
 Ø60 mm aluminium ring





Elis



T418 / T419 / T420 / T421

_blank design studio

A light-sculpting painting. Elis is a single-light recessed plaster lamp. With its square projecting frame available in four finishes, it stands out for its essential nature.

IT Un quadro che scolpisce la luce. La lampada ad incasso per cartongesso ad una luce Elis, grazie alla cornice sporgente quadrata presentata in quattro finiture, si distingue per la sua essenzialità.

ES Un cuadro que esculpe la luz. La luminaria empotrable Elis de una luz para paredes de pladur, con su marco saliente cuadrado presentado en cuatro acabados, destaca por su esencialidad.

DE Ein Gemälde, das das Licht formt. Die einflammige Einbauleuchte aus Gips Elis mit ihrem quadratischen, vorspringenden Rahmen, der in vier Ausführungen angeboten wird, zeichnet sich durch ihre Wesentlichkeit aus.

RU Картина, излучающая свет. Встраиваемый светильник Elis с одним источником света, предназначенный для гипсокартона, отличается лаконичностью и имеет выступающую квадратную рамку с четырьмя вариантами отделки.

Material / Materiale / Material / Material / Материал

Plaster and aluminium / Gesso e alluminio / Gips und Aluminium / Yeso y aluminio / Гипс и алюминий

Finish / Finitura / Fertigstellen / Terminar / закончить

Matte black / Nero opaco / Mattschwarz / Negro mate / матовый черный

Matte white / Bianco opaco / Matt Weiß / Blanco Mate / Мэтт Уайт

Brushed brass / Ottone spazzolato / Gebürstetes Messing / Latón cepillado / Матовая латунь

Brushed copper / Rame spazzolato / Gebürstetes Kupfer / Cobre cepillado / Матовая медь

Light source / Fonte di luce / Lichtquelle / Fuente de luz / Источник света

GU10 x 40W

Type-approvals / Omologazioni / Zulassungen / Homologaciones / Разрешения



Ø 120 mm - Recommended installation hole
 Ø 120 mm - Foro per installazione suggerito
 Ø 120 mm - Empfohlene Einbauöffnung
 Ø 120 mm - Orificio para instalación aconsejado
 Ø 120 mm - Рекомендуемое установочное отверстие

Once installed in the plasterboard, it is flush with the ceiling and it can be painted over.
 Dopo averlo installato nel cartongesso risulta parte integrante del soffitto e può essere tinteggiato.
 Nach dem Einbau in Gipskartonplatten ist es ein integraler Bestandteil der Decke und kann gestrichen werden.
 Tras su instalación en pladur, forma parte integrante del techo y puede pintarse.
 После установки в гипсокартон становится составной частью потолка и может быть окрашен



↓ →
T418 Elis
 Recessed plaster spotlight with
 matte black painted aluminium frame and bottom
 GU10 x 1x40W
 w80 x d80 mm aluminium frame



← ↑
T419 Elis
 Recessed plaster spotlight with
 matte white painted aluminium frame
 GU10 x 1x40W
 w80 x d80 mm aluminium frame



↑ → →

T420 Elis

Recessed plaster spotlight with
brushed brass finished aluminium frame
GU10 x 1x40W
w80 x d80 mm aluminium frame



← ↑

T421 Elis

Recessed plaster spotlight with
brushed copper finished aluminium frame
GU10 x 1x40W
w80 x d80 mm aluminium frame

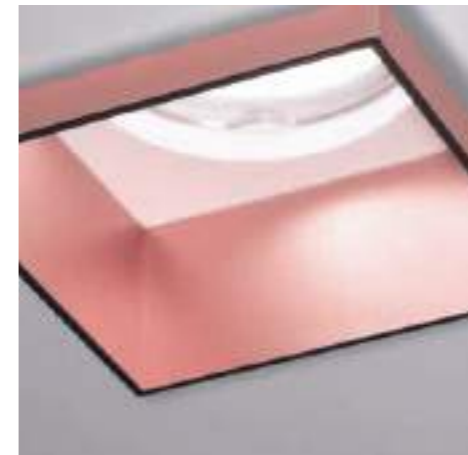

Elis Raso



T414 / T415 / T416 / T417

_blank design studio

Essential light-modelling shapes. In the 'flush' version, Elis features a square flush frame in four alternative finishes. It frames light and adds a discreet detail to any room.

IT Forme essenziali che scolpiscono la luce. Nella versione "raso" Elis presenta una cornice filomuro quadrata in quattro alternative di finiture, capace di incorniciare la luce aggiungendo un dettaglio discreto all'ambiente.

ES Formas esenciales que esculpen la luz. En la versión empotrable, Elis presenta un marco de pared cuadrado enrasado en cuatro acabados alternativos, que enmarca la luz y añade un discreto detalle al ambiente.

DE Wesentliche Formen, die das Licht formen. In der satinieren Version verfügt Elis über einen quadratischen, bündigen Wandrahmen in vier alternativen Ausführungen, der die Leuchte einrahmt und dem Raum ein diskretes Detail verleiht.

RU Сдержанные формы, моделирующие свет. Светильник Elis в версии заподлицо имеет квадратную рамку, устанавливаемую вровень с поверхностью, с четырьмя вариантами отделки: световой контур, добавляющий помещению элегантный штрих.

Material / Materiale / Material / Material / Material / Material

Plaster and aluminium / Gesso e alluminio / Gips und Aluminium / Yeso y aluminio / Гипс и алюминий

Finish / Finitura / Fertigstellen / Terminar / закончить

Matte black / Nero opaco / Mattschwarz / Negro mate / матовый черный

Matte white / Bianco opaco / Matt Weiß / Blanco Mate / Мэтт Уайт

Brushed brass / Ottone spazzolato / Gebürstetes Messing / Latón cepillado / Матовая латунь

Brushed copper / Rame spazzolato / Gebürstetes Kupfer / Cobre cepillado / Матовая медь

Light source / Fonte di luce / Lichtquelle / Fuente de luz / Источник света

GU10 x 40W

Type-approvals / Omologazioni / Zulassungen / Homologaciones / Разрешения



Ø 110 mm - Recommended installation hole
 Ø 110 mm - Foro per installazione suggerito
 Ø 110 mm - Empfohlene Einbauöffnung
 Ø 110 mm - Orificio para instalación aconsejado
 Ø 110 mm - Рекомендуемое установочное отверстие

Once installed in the plasterboard, it is flush with the ceiling and it can be painted over.
 Dopo averlo installato nel cartongesso risulta parte integrante del soffitto e può essere tinteggiato.
 Nach dem Einbau in Gipskartonplatten ist es ein integraler Bestandteil der Decke und kann gestrichen werden.
 Tras su instalación en pladur, forma parte integrante del techo y puede pintarse.
 После установки в гипсокартон становится составной частью потолка и может быть окрашен.



Recessed lights

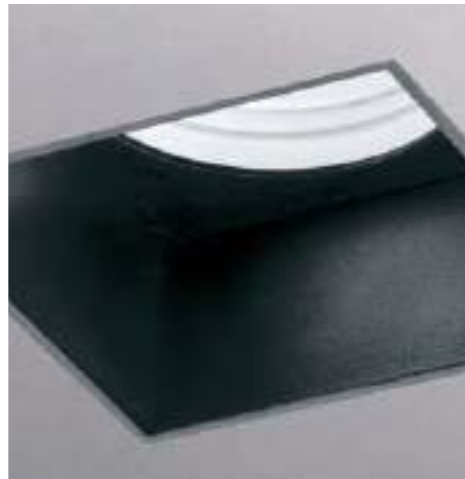

↓ →
T414 Elis Raso
 Flush recessed plaster spotlight with
 matte black painted aluminium frame and bottom
 GU10 x 1x40W
 w80 x d80 mm aluminium frame



← ↑
T415 Elis Raso
 Flush recessed plaster spotlight with
 matte white painted aluminium frame
 GU10 x 1x40W
 w80 x d80 mm aluminium frame



↑→
T416 Elis Raso
 Flush recessed plaster spotlight with
 brushed brass finished aluminium frame
 GU10 x 1x40W
 w80 x d80 mm aluminium frame



←↓
T417 Elis Raso
 Flush recessed plaster spotlight with
 brushed copper finished aluminium frame
 GU10 x 1x40W
 w80 x d80 mm aluminium frame





Rhodia



T464 / T465 / T446 / T467
T479* / T480* / T481* / T482*

_blank design studio

The exclusivity of details. Rhodia shapes the space with understated and unique accents. Thanks to its discreet size and protruding painted aluminium frame, it blends in harmoniously with the lines of the room.

IT L'esclusività dei dettagli. Rhodia firma gli spazi con discrezione ed accenti unici. La dimensione discreta e la cornice sporgente in alluminio verniciato permettono di integrarla in armonia con le linee degli ambienti.

ES La exclusividad de los detalles. Rhodia marca los espacios con discreción y acentos únicos. Su tamaño discreto y su marco saliente de aluminio pintado le permiten integrarse armoniosamente en las líneas de los ambientes.

DE Die Exklusivität der Details. Rhodia kennzeichnet Räume mit Diskretion und einzigartigen Akzenten. Durch seine diskrete Größe und den vorstehenden Rahmen aus lackiertem Aluminium fügt sie sich harmonisch in die Linienführung des Raumes ein.

RU Уникальность деталей. Rhodia сдержанно моделирует пространство, привнося уникальные акценты. Компактный размер и выступающая рамка из окрашенного алюминия позволяют светильнику гармонично вписываться в помещения.

Material / Materiale / Material / Material / Material / Material / Material / Material

Plaster and aluminium / Gesso e alluminio / Gips und Aluminium / Yeso y aluminio / Гипс и алюминий

Finish / Finitura / Fertigstellen / Terminar / закончить

Matte black / Nero opaco / Mattschwarz / Negro mate / матовый черный

Matte white / Bianco opaco / Matt Weiß / Blanco Mate / Мэтт Уайт

Brushed brass / Ottone spazzolato / Gebürstetes Messing / Latón cepillado / Матовая латунь

Brushed copper / Rame spazzolato / Gebürstetes Kupfer / Cobre cepillado / Матовая медь

Light source / Fonte di luce / Lichtquelle / Fuente de luz / Источник света

LED module 7W
(* dimmable version)

Type-approvals / Omologazioni / Zulassungen / Homologaciones / Разрешения



Ø 100 mm - Recommended installation hole
Ø 100 mm - Foro per installazione suggerito
Ø 100 mm - Empfohlene Einbauöffnung
Ø 100 mm - Orificio para instalación aconsejado
Ø 100 mm - Рекомендуемое установочное отверстие

Once installed in the plasterboard, it is flush with the ceiling and it can be painted over.
Dopo averlo installato nel cartongesso risulta parte integrante del soffitto e può essere tinteggiato.
Nach dem Einbau in Gipskartonplatten ist es ein integraler Bestandteil der Decke und kann gestrichen werden.
Tras su instalación en pladur, forma parte integrante del techo y puede pintarse.
После установки в гипсокартон становится составной частью потолка и может быть окрашен



→↓
T464 / T479 Rhodia
Recessed plaster light with
matte black painted ring finishing
LED Module – 7W
Ø20 mm aluminium ring



←↑
T465 / T480 Rhodia
Recessed plaster light with
matte white painted ring finishing
LED Module – 7W
Ø20 mm aluminium ring



← ↓
T467 / T482 Rhodia
Recessed plaster lamp
with brushed copper ring finishing
LED Module – 7W
Ø20 mm aluminium ring



↑ →
T466 / T481 Rhodia
Recessed plaster lamp with
brushed brass ring finishing
LED Module – 7W
Ø20 mm aluminium ring



Rhodia



T468 / T469 / T470 / T471
T483* / T484* / T485* / T486*

_blank design studio

A functional detail. This version of Rhodia incorporates all the electronics in the lighting fixture. It can be easily inspected using the ring, without any masonry works. Shape meets function in this lamp, blending elegantly with the geometries of the environment.

IT Un dettaglio funzionale. Questa versione di Rhodia, incorpora l'elettronica completa nel corpo illuminante e grazie all'anello può essere facilmente ispezionata senza opere. La silhouette semplice incorpora la funzione fondendosi elegantemente con le geometrie dell'ambiente.

ES Un detalle funcional. Esta versión de Rhodia incorpora toda la electrónica en el cuerpo de la luminaria y, gracias al anillo, puede inspeccionarse fácilmente sin obras. Su sencilla silueta incorpora funcionalidad, combinándose con elegancia con las geometrías del entorno.

DE Ein funktionelles Detail. Bei dieser Version von Rhodia ist die komplette Elektronik in den Körper der Leuchte integriert und kann dank des Rings ohne Arbeiten leicht inspiziert werden. Die schlichte Silhouette integriert die Funktion und fügt sich elegant in die Geometrie der Umgebung ein.

RU Функциональная деталь. В этой версии Rhodia вся электроника находится в корпусе светильника и легко доступна для осмотра благодаря кольцу. Функциональный световой контур отличается изящной простотой и элегантно сливается с геометрией интерьера.

Material / Materiale / Material / Material / Material / Material

Plaster and aluminium / Gesso e alluminio / Gips und Aluminium / Yeso y aluminio / Гипс и алюминий

Finish / Finitura / Fertigstellen / Terminar / закончить

Matte black / Nero opaco / Mattschwarz / Negro mate / матовый черный

Matte white / Bianco opaco / Matt Weiß / Blanco Mate / Мэтт Уайт

Brushed brass / Ottone spazzolato / Gebürstetes Messing / Latón cepillado / Матовая латунь

Brushed copper / Rame spazzolato / Gebürstetes Kupfer / Cobre cepillado / Матовая медь

Light source / Fonte di luce / Lichtquelle / Fuente de luz / Источник света

LED module 10,5W
(* dimmable version)

Type-approvals / Omologazioni / Zulassungen / Homologaciones / Разрешения



Ø 150 mm - Recommended installation hole
Ø 150 mm - Foro per installazione suggerito
Ø 150 mm - Empfohlene Einbauöffnung
Ø 150 mm - Orificio para instalación aconsejado
Ø 150 mm - Рекомендуемое установочное отверстие

Once installed in the plasterboard, it is flush with the ceiling and it can be painted over.
Dopo averlo installato nel cartongesso risulta parte integrante del soffitto e può essere tinteggiato.
Nach dem Einbau in Gipskartonplatten ist es ein integraler Bestandteil der Decke und kann gestrichen werden.
Tras su instalación en pladur, forma parte integrante del techo y puede pintarse.
После установки в гипсокартон становится составной частью потолка и может быть окрашен.





↓ →
T468 / T483 Rhodia
 Recessed plaster light with
 matte black painted ring finishing
 LED Module – 10,5W
 Ø20 mm aluminium ring



← ↑
T469 / T484 Rhodia
 Recessed plaster light with
 matte white painted ring finishing
 LED Module – 10,5W
 Ø20 mm aluminium ring



↓ →
T470 / T485 Rhodia
 Recessed plaster lamp with
 brushed brass ring finishing
 LED Module – 10,5W
 Ø20 mm aluminium ring



← ↑
T471 / T486 Rhodia
 Recessed plaster lamp with
 brushed copper ring finishing
 LED Module – 10,5W
 Ø20 mm aluminium ring



Lelanto



T356 / T357 / T412 / T413

_blank design studio

Directional light. Lelanto - adjustable recessed plaster spotlight with directional beam to adjust it as required. The dual emission version further accentuates its versatility, while the visible aluminium frame - available in two different finishes - allows it to blend in with the architectural style of any space.

IT Luce direzionabile. Lelanto, faretto orientabile da incasso per cartongesso, permette di direzionare il fascio luminoso in funzione delle esigenze. La versione a doppia emissione ne accentua ulteriormente la duttilità, la cornice a vista in alluminio - disponibile in due diverse finiture - le consente di sposarsi con lo stile architettonico di ogni spazio.

ES Luz orientable. Lelanto, foco empotrable orientable para pladur, permite dirigir el haz de luz según las necesidades. La versión de doble emisión acentúa aún más su ductilidad y el marco de aluminio visible - disponible en dos acabados diferentes - le permite integrarse en el estilo arquitectónico de cualquier espacio.

DE Lenkbares Licht. Lelanto, ein verstellbarer Einbaustrahler für Gipskartonplatten, ermöglicht die Ausrichtung des Lichtstrahls nach Bedarf. Die Version mit doppelter Emission unterstreicht seine Flexibilität, und der sichtbare Aluminiumrahmen, der in zwei verschiedenen Ausführungen erhältlich ist, ermöglicht es ihm, sich in den architektonischen Stil jedes Raumes einzufügen.

RU Направленный свет. Lelanto, поворотный встраиваемый точечный светильник, предназначенный для гипсокартона, позволяет направить луч света в нужную сторону. Двойная версия подчеркивает его универсальность, а видимая алюминиевая рамка, предлагаемая в двух вариантах отделки, обеспечивает гармоничное сочетание с архитектурным стилем любого помещения.

Material / Materiale / Material / Material / Material / Material

Plaster and aluminium / Gesso e alluminio / Gips und Aluminium / Yeso y aluminio / Гипс и алюминий

Finish / Finitura / Fertigstellen / Terminar / закончить

Matte black / Nero opaco / Mattschwarz / Negro mate / матовый черный

Matte white / Bianco opaco / Matt Weiß / Blanco Mate / Мэйт Уайт

Light source / Fonte di luce / Lichtquelle / Fuente de luz / Источник света

GU10 x 40W

Type-approvals / Omologazioni / Zulassungen / Homologaciones / Разрешения



Once installed in the plasterboard, it is flush with the ceiling and it can be painted over.
Dopo averlo installato nel cartongesso risulta parte integrante del soffitto e può essere tinteggiato.
Nach dem Einbau in Gipskartonplatten ist es ein integraler Bestandteil der Decke und kann gestrichen werden.
Tras su instalación en pladur, forma parte integrante del techo y puede pintarse.
После установки в гипсокартон становится составной частью потолка и может быть окрашен





↑→
T357 Lelanto
 Two-lights adjustable recessed plasterboard spotlight
 with matte black painted ring finishing. Adjustable 15° tilt light.
 GU10 - 2x40W
 Ø50 mm double aluminium ring



←↓
T356 Lelanto
 One-light adjustable recessed plasterboard spotlight
 with matte black painted ring finishing. Adjustable 15° tilt light.
 GU10 - 1x40W
 Ø50 mm aluminium ring

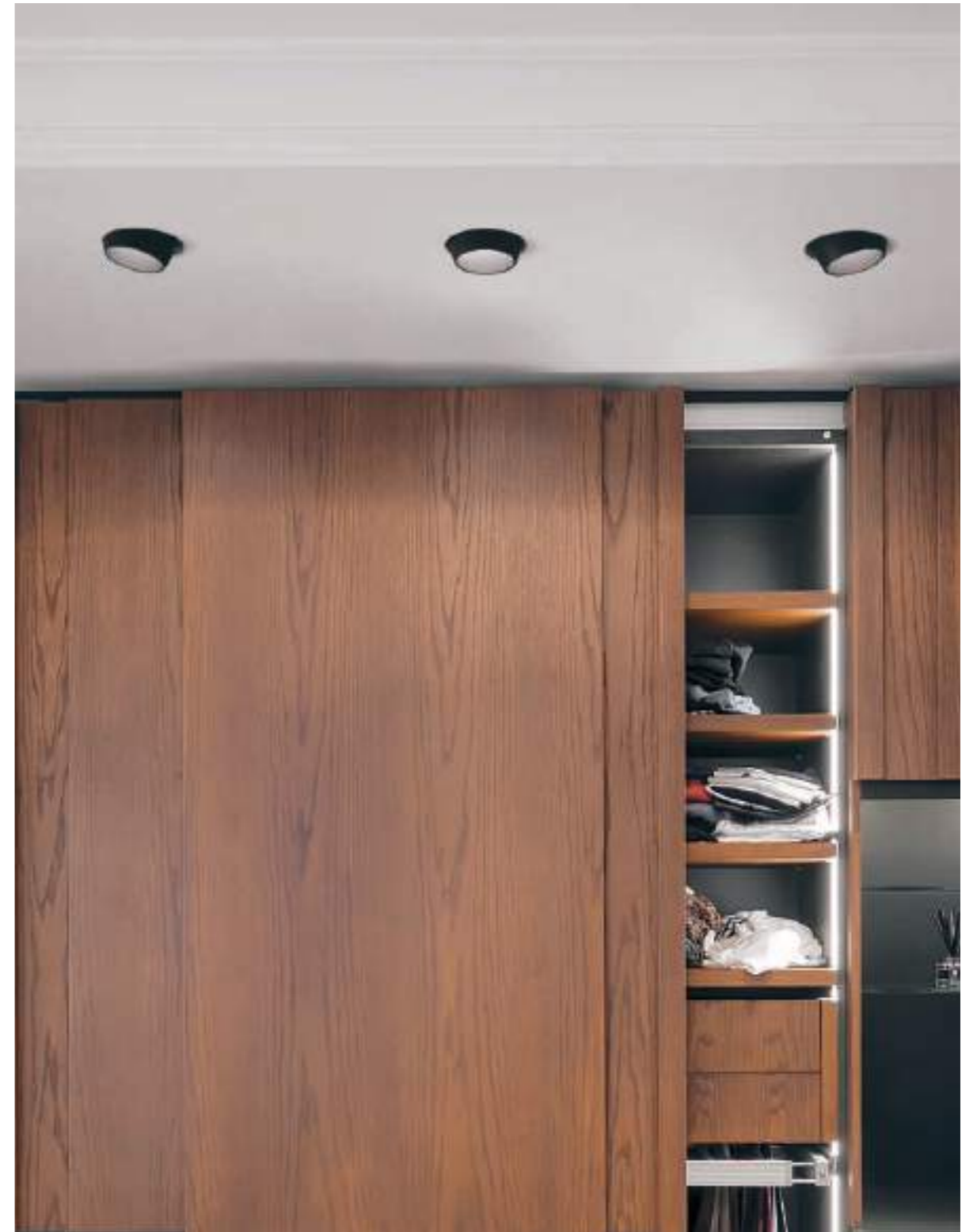

Recessed lights



T412 Lelanto

One-light adjustable recessed plasterboard spotlight with matte white painted ring finishing. Adjustable 15° tilt light.
GU10 - 1x40W
Ø50 mm aluminium ring



T413 Lelanto

Two-lights adjustable recessed plasterboard spotlight with matte white painted ring finishing. Adjustable 15° tilt light.
GU10 - 2x40W
Ø50 mm double aluminium ring





Filiatrà



T337 / T338
T381 / T382 / T383

_blank design studio

Multifaceted simplicity. The Filiatrà recessed plaster lamp, with its range of available shapes and combinations - white or black painted inner edge and opal glass options - is a discreet and versatile solution.

IT Semplicità poliedrica. La lampada a incasso per cartongesso Filiatrà, con la sua gamma di forme e combinazioni disponibili - con bordo interno verniciato bianco o nero ed opzioni in vetro opalino - è una soluzione discreta e versatile.

ES Simplicidad polifacética. La luminaria empotrable Filiatrà para pladur, con su gama de formas y combinaciones disponibles - con borde interior pintado en blanco o negro y opciones de vidrio opalino - es una solución discreta y versátil.

DE Vielfältige Einfachheit. Die Einbauleuchte für Gipskarton Filiatrà ist mit ihren verschiedenen Formen und Kombinationen - mit weiß oder schwarz lackiertem Innenrand und Opalglas - eine diskrete und vielseitige Lösung.

RU Многогранная простота. Предназначенный для гипсокартона встраиваемый светильник Filiatrà, с многообразием предлагаемых форм и комбинаций, с внутренней рамкой, окрашенной в белый или черный цвет, включая возможные варианты с опаловым стеклом, является благородным и универсальным решением.

Material / Materiale / Material / Material / Material / Material / Material

Plaster / Gesso / Gips / Yeso / Гипсовый

Plaster and aluminium / Gesso e alluminio / Gips und Aluminium / Yeso y aluminio / Гипс и алюминий

Plaster, aluminium and glass / Gesso, alluminio e vetro / Gips, Aluminium und Glas / Yeso, aluminio y vidrio / Гипс, алюминий и стекло

Finish / Finitura / Fertigstellen / Terminar / закончить

Matte black / Nero opaco / Mattschwarz / Negro mate / матовый черный

Matte white / Bianco opaco / Mattweiß / Blanco Mate / Мэтт Уайт

Light source / Fonte di luce / Lichtquelle / Fuente de luz / Источник света

GX53 x 10W

Type-approvals / Omologazioni / Zulassungen / Homologaciones / Разрешения



Once installed in the plasterboard, it is flush with the ceiling and it can be painted over.
Dopo averlo installato nel cartongesso risulta parte integrante del soffitto e può essere tinteggiato.
Nach dem Einbau in Gipskartonplatten ist es ein integraler Bestandteil der Decke und kann gestrichen werden.
Tras su instalación en pladur, forma parte integrante del techo y puede pintarse.
После установки в гипсокартон становится составной частью потолка и может быть окрашен.



↓ →
T337 Filiatrà
Recessed plaster spotlight
GX53 - 1x10W
Ø80 mm lighted hole

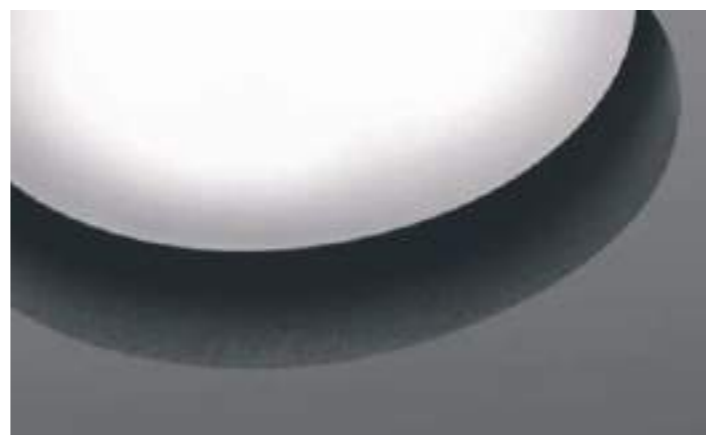

← ↑
T338 Filiatrà
Recessed plaster spotlight
with black painted inner edge
GX53 - 1x10W
Ø80 mm lighted hole



↑→
T381 Filiatrà
 Recessed plaster spotlight
 GX53 – 1x10W
 w80 x d80 mm lighted hole

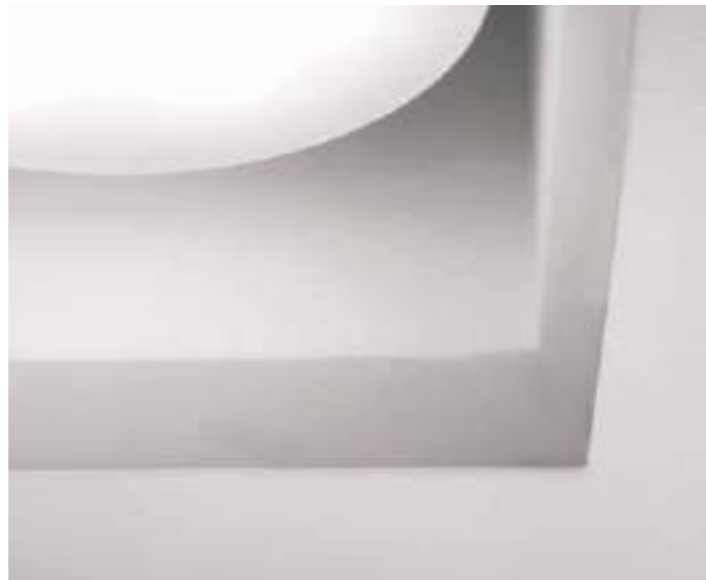

←↓
T382 Filiatrà
 Recessed plaster spotlight with
 black painted inner edge and opal glass
 GX53 – 1x10W
 w80 x d80 mm lighted hole



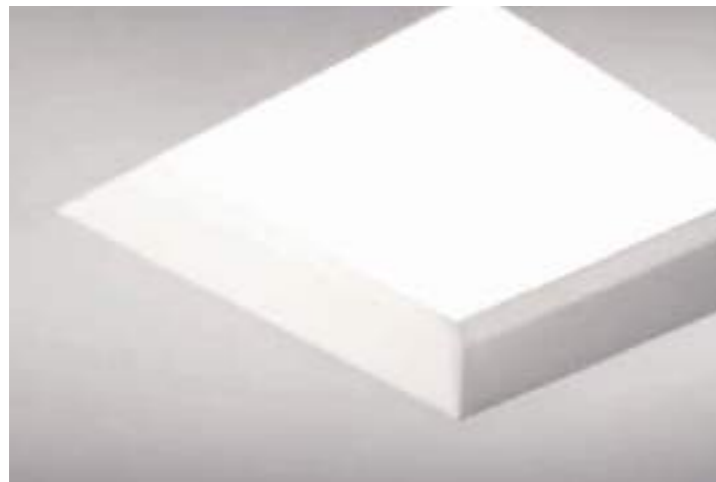

↓→
T383 Filiatrà
Recessed plaster spotlight with opal glass
GX53 – 1x10W
w80 x d80 mm lighted hole



Phocis



T384

_blank design studio

Forging light. Phocis is a recessed plaster lamp, equipped with a honeycomb grid that regulates the light beam, limiting the lateral emission. Seen from the side, the light source is concealed, and it reveals its presence only through the pinpoint effect caused by bouncing light. The black painted ring is its iconic feature.

IT Plasmare la luce. Phocis è la lampada a incasso per cartongesso dotata di griglia a nido d'ape che regola il fascio luminoso, limitando l'emissione laterale. Vista lateralmente la fonte luminosa viene celata rivelando la sua presenza solo dagli effetti puntuali della luce di rimbalzo. La ghiera, verniciata nera, resta l'elemento distintivo ed iconico.

DE Licht formen. Phocis ist die Einbauleuchte für Gipskartonplatten, die mit einem Wabengitter ausgestattet ist, das den Lichtstrahl reguliert und die seitliche Emission begrenzt. Von der Seite gesehen ist die Lichtquelle verdeckt und wird nur durch die punktuellen Effekte des zurückprallenden Lichts sichtbar. Der schwarz lackierte Ring bleibt das charakteristische und ikonische Element.

ES Dar forma a la luz. Phocis es la luminaria empotrable para pladur equipada con una rejilla en forma de panal que regula el haz luminoso, limitando la emisión lateral. Vista de perfil, la fuente de luz queda oculta, revelando su presencia solo por los efectos puntuales de la luz de rebote. El bisel, pintado de negro, sigue siendo el elemento distintivo e icónico.

RU Моделирование света. Phocis - встраиваемый светильник, предназначенный для гипсокартона, оснащается ячеистой решеткой, которая регулирует световой пучок, ограничивая боковое излучение. При взгляде сбоку источник света скрыт, поэтому о его присутствии можно догадаться только благодаря точечным эффектам, создаваемым отраженным светом. Окрашенное в черный цвет кольцо является отличительным, фирменным элементом этого светильника.

Material / Materiale / Material / Material / Material / Material

Plaster and aluminium / Cesso e alluminio / Gips und Aluminium / Yeso y aluminio / Гипс и алюминий

Finish / Finitura / Fertigstellen / Terminar / закончить

Matte black / Nero opaco / Mattschwarz / Negro mate / матовый черный

Light source / Fonte di luce / Lichtquelle / Fuente de luz / Источник света

GU10 x 40W

Type-approvals / Omologazioni / Zulassungen / Homologaciones / Разрешения



Ø 100 mm - Recommended installation hole
Ø 100 mm - Foro per installazione suggerito
Ø 100 mm - Empfohlene Einbauöffnung
Ø 100 mm - Orificio para instalación aconsejado
Ø 100 mm - Рекомендуемое установочное отверстие

Once installed in the plasterboard, it is flush with the ceiling and it can be painted over.
Dopo averlo installato nel cartongesso risulta parte integrante del soffitto e può essere tinteggiato.
Nach dem Einbau in Gipskartonplatten ist es ein integraler Bestandteil der Decke und kann gestrichen werden.
Tras su instalación en pladur, forma parte integrante del techo y puede pintarse.
После установки в гипсокартон становится составной частью потолка и может быть окрашен



Recessed lights

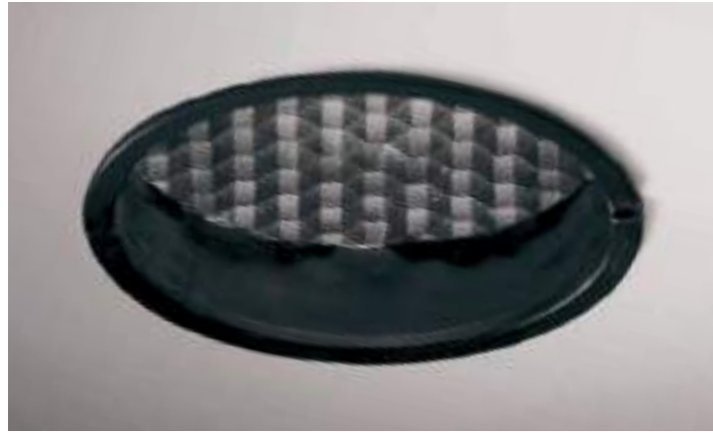

↑→
T384 Phocis
Recessed plaster spotlight with
matte black painted ring and mesh finishing
GU10 – 1x40W
Ø60 mm aluminium ring



Recessed lights



Doride



T353 / T354

Tecnico R&D

Light inspires, shape defines. The Doride single-light recessed plaster lamp, available in the round or square version, combines minimalist aesthetics and function. The hole, which follows the lamp geometry, creates a discreet yet sophisticated detail. The IP44 degree of protection makes it suitable for installation in humid environments.

IT La luce ispira, la forma la definisce. Nella lampada ad incasso per cartongesso ad una luce Doride, disponibile in versione tonda o quadrata, si uniscono estetica minimale e funzionalità. Il foro che segue la geometria della lampada, crea un dettaglio discreto ma sofisticato. Il grado di protezione IP44 la rende adatta anche ad installazioni in ambiente con presenza di umidità.

ES La luz inspira, la forma define. En la luminaria empotrada Doride de una luz para pladur, disponible en versión redonda o cuadrada, se combinan la estética minimalista y la funcionalidad. El orificio, que sigue la geometría de la lámpara, crea un detalle discreto pero sofisticado. El grado de protección IP44 también la hace adecuada para su instalación en entornos húmedos.

DE Licht inspiriert, Form definiert. In der einflammigen Einbauleuchte für Gipskarton Doride, die in runder oder quadratischer Ausführung erhältlich ist, vereinen sich minimalistische Ästhetik und Funktionalität. Das Loch, das der Geometrie der Leuchte folgt, schafft ein diskretes, aber raffiniertes Detail. Dank des Schutzgrades IP44 ist es auch für die Installation in feuchten Umgebungen geeignet.

RU Свет вдохновляет, форма дарит ему очертания. Во встраиваемом светильнике Doride с одним источником света, предназначенном для гипсокартона и доступном в круглом или квадратном исполнении, сочетаются эстетика минимализма и функциональность. Отверстие, повторяющее геометрию светильника, представляет собой неброскую, но изысканную деталь. Степень защиты IP44 позволяет устанавливать его во влажных помещениях.

Material / Materiale / Material / Material / Material / Material / Material

Plaster and aluminium / Gesso e alluminio / Gips und Aluminium / Yeso y aluminio / Гипс и алюминий

Finish / Finitura / Fertigstellen / Terminar / закончить

White / Bianco / Weiß / Blanco / белый

Light source / Fonte di luce / Lichtquelle / Fuente de luz / Источник света

GU10 x 40W

Type-approvals / Omologazioni / Zulassungen / Homologaciones / Разрешения



Ø 140 mm / w140 x d140 mm - Recommended installation hole
 Ø 140 mm / w140 x d140 mm - Foro per installazione suggerito
 Ø 140 mm / w140 x d140 mm - Empfohlene Einbauöffnung
 Ø 140 mm / w140 x d140 mm - Orificio para instalación aconsejado
 Ø 140 mm / w140 x d140 mm - Рекомендуемое установочное отверстие

Once installed in the plasterboard, it is flush with the ceiling and it can be painted over.

Dopo averlo installato nel cartongesso risulta parte integrante del soffitto e può essere tinteggiato.
 Nach dem Einbau in Gipskartonplatten ist es ein integraler Bestandteil der Decke und kann gestrichen werden.
 Tras su instalación en pladur, forma parte integrante del techo y puede pintarse.
 После установки в гипсокартон становится составной частью потолка и может быть окрашен

Degree of protection: IP44 / Grado di protezione IP44 / Schutzart IP44 / Grado de protección IP44 / Уровень защиты IP44



↓ →
T353 Doride
 Recessed plaster spotlight.
 Internal metal housing with IP44 protection rating
 GU10 – 1x40W
 Ø90 mm lighted hole



← ↑
T354 Doride
 Recessed plaster spotlight.
 Internal metal housing with IP44 protection rating
 GU10 – 1x40W
 w90 x d90 mm lighted hole

Heraea



T255 / T256 / T257

Acero Studio Design

Harmony of contrasts. Heraea - a recessed plaster lamp, available in the two, three or five-light version - creates an interplay of solids and voids. Flush elements intertwine with embossed frames, making architectural surfaces more dynamic.

IT Armonia di contrasti. Heraea, incasso per controsoffitti disponibile nelle versioni a due, tre o cinque luci, crea un gioco di pieni e vuoti: elementi a raso si intrecciano a cornici in rilievo, conferendo dinamismo alle superfici dell'architettura.

ES Armonía de contrastes. Heraea, una luminaria empotrable en el techo disponible en versiones de dos, tres o cinco luces, crea un juego de sólidos y vacíos: elementos enrasados se entrelazan con marcos en relieve, aportando dinamismo a las superficies de la arquitectura.

DE Harmonie der Gegensätze. Heraea, eine Einbauleuchte für Decken, die in zwei-, drei- oder fünfflammiger Ausführung erhältlich ist, erzeugt ein Wechselspiel von Voll- und Hohlräumen: Flächenbündige Elemente verflechten sich mit Reliefrahmen und verleihen den Oberflächen der Architektur Dynamik.

RU Гармония контрастов. Встраиваемый светильник Heraea для потолков из гипсокартона, доступный в версиях с двумя, тремя или пятью источниками света, создает игру объемов: плоские элементы сплетаются с рельефными рамками, придавая динамизм поверхностям помещения.

Material / Materiale / Material / Material / Material

Plaster / Gesso / Gips / Yeso / Гипсовый

Finish / Finitura / Fertigstellen / Terminar / закончить

White / Bianco / Weiß / Blanco / белый

Light source / Fonte di luce / Lichtquelle / Fuente de luz / Источник света

GU10 x 40W

Type-approvals / Omologazioni / Zulassungen / Homologaciones / Разрешения



Once installed in the plasterboard, it is flush with the ceiling and it can be painted over.
Dopo averlo installato nel cartongesso risulta parte integrante del soffitto e può essere tinteggiato.
Nach dem Einbau in Gipskartonplatten ist es ein integraler Bestandteil der Decke und kann gestrichen werden.
Tras su instalación en pladur, forma parte integrante del techo y puede pintarse.
После установки в гипсокартон становится составной частью потолка и может быть окрашен



↓ →
T255 Heraea
 Two-lights recessed plaster spotlight
 GU10 - 2x40W
 Visible area w185 x d135 mm
 (two lighted holes w80 x d80 mm)



← ↓
T256 Heraea
 Three-lights recessed plaster spotlight
 GU10 - 3x40W
 Visible area w240 x d200 mm
 (three lighted holes w80 x d80 mm)





↓↓→
T257 Heraea
 Five-lights recessed plaster spotlight
 GU10 – 5x40W
 Visible area w330 x d240 mm
 (five lighted holes w80 x d80 mm)



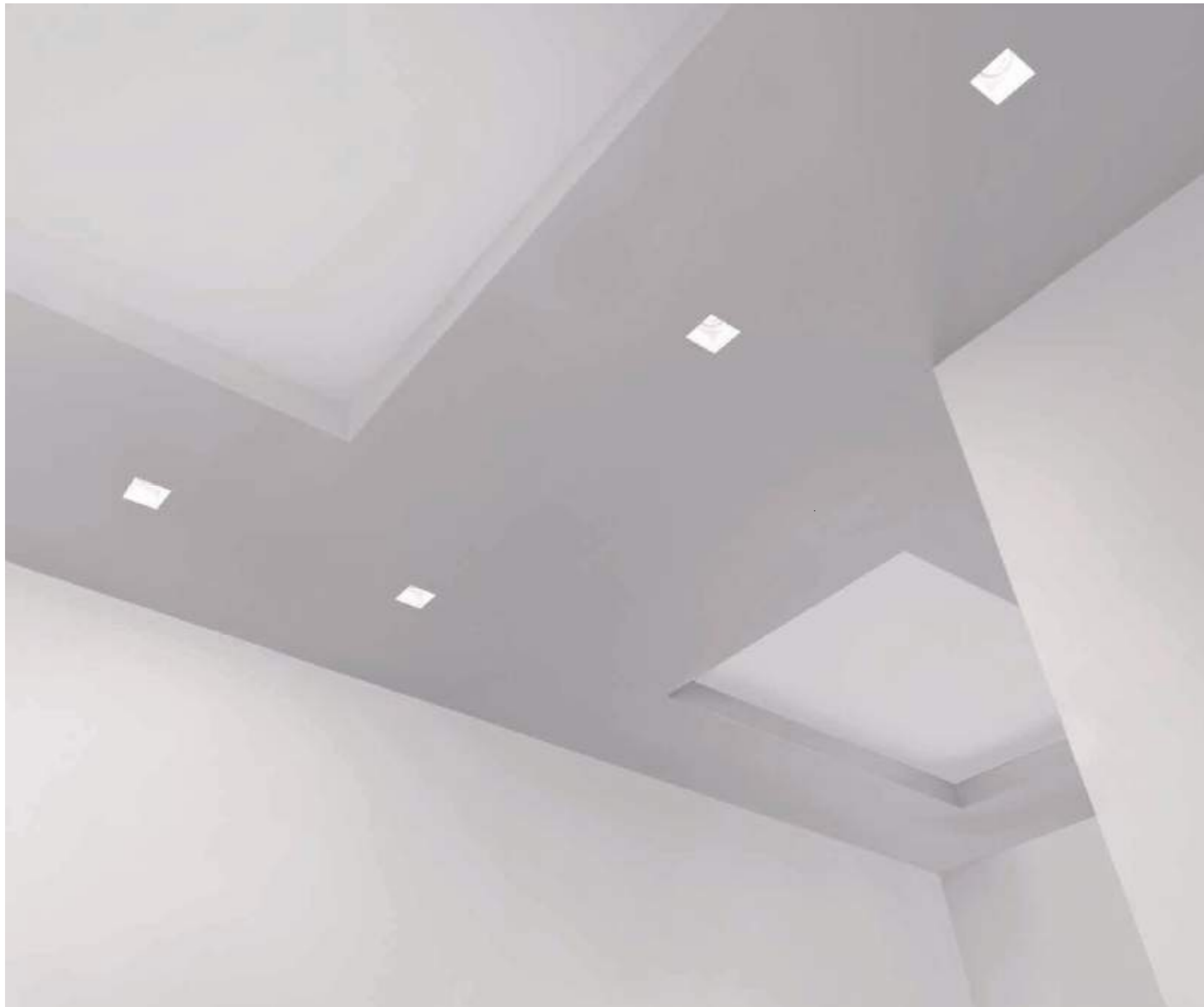

Siris



T165

Tecnico R&D

Understated and essential. Siris round light source - a recessed plaster lamp - elegantly fills the square space in which it is installed, providing an understated and essential light point. The fusion with the ceiling creates a discreet detail that makes light the protagonist.

IT Rigorosa ed essenziale. La sorgente luminosa circolare di Siris - lampada ad incasso per cartongesso - riempie elegantemente lo spazio quadrato in cui è inserita, restituendo un punto luce sobrio ed essenziale. La fusione con il soffitto crea un dettaglio discreto che rende protagonista la luce.

ES Rigurosa y esencial. La fuente de luz circular de Siris - una lámpara empotrable para pladur - llena con elegancia el espacio cuadrado en el que se coloca, proporcionando un punto de luz sobrio y esencial. La fusión con el techo crea un discreto detalle que convierte a la luz en protagonista.

DE Streng und wesentlich. Die runde Lichtquelle von Siris - eine Einbauleuchte für Gipskarton - füllt den quadratischen Raum, in den sie eingesetzt ist, auf elegante Weise aus und bietet einen nüchternen und wesentlichen Lichtpunkt. Die Verschmelzung mit der Decke schafft ein diskretes Detail, das das Licht zum Protagonisten macht.

RU Лаконичная строгость. Встраиваемый светильник Siris, предназначенный для гипсокартона, комплектуется круглым источником света в элегантном квадратном обрамлении и обеспечивает сдержанное и лаконичное освещение. Благодаря слиянию с потолком сам светильник становится практически незаметным, выводя на первый план свет.

Material / Materiale / Material / Material / Material

Plaster / Gesso / Gips / Yeso / Гипсовый

Finish / Finitura / Fertigstellen / Terminar / закончить

White / Bianco / Weiß / Blanco / белый

Light source / Fonte di Luce / Lichtquelle / Fuente de luz / Источник света

CU10 x 40W

Type-approvals / Omologazioni / Zulassungen / Homologaciones / Разрешения



Ø 100 mm - Recommended installation hole
 Ø 100 mm - Foro per installazione suggerito
 Ø 100 mm - Empfohlene Einbauöffnung
 Ø 100 mm - Orificio para instalación aconsejado
 Ø 100 mm - Рекомендуемое установочное отверстие

Once installed in the plasterboard, it is flush with the ceiling and it can be painted over.
 Dopo averlo installato nel cartongesso risulta parte integrante del soffitto e può essere tinteggiato.
 Nach dem Einbau in Gipskartonplatten ist es ein integraler Bestandteil der Decke und kann gestrichen werden.
 Tras su instalación en pladur, forma parte integrante del techo y puede pintarse.
 После установки в гипсокартон становится составной частью потолка и может быть окрашен

Attica



T04 / T28 / T177

Tecnico R&D

A sign of light. Attica - an invisible recessed plaster lamp, with fixed or adjustable light - is ideal both as a vertical light beam, and as source of light to illuminate any detail in the room. A sophisticated option for contemporary ceilings.

IT Un segno di luce. Attica, incasso invisibile per controsoffitti, con la sua natura duplice - luce fissa o orientabile - risponde sia all'esigenza di un fascio luminoso verticale quanto alla necessità di direzionare il fascio di luce per illuminare i dettagli dell'ambiente. Opzione raffinata per controsoffitti contemporanei.

DE Ein Zeichen des Lichts. Attica, eine unsichtbare Decken-einbauleuchte, erfüllt mit ihrer Doppelnatur - festes oder verstellbares Licht - sowohl den Bedarf an einem vertikalen Lichtstrahl als auch den Bedarf, den Lichtstrahl zu lenken, um Details im Raum zu beleuchten. Eine raffinierte Option für moderne Decken.

ES Un signo de luz. Attica, un plafón empotrable invisible, con su doble naturaleza - luz fija u orientable - satisface tanto la necesidad de un haz de luz vertical como la de dirigir el haz de luz para iluminar los detalles del ambiente. Opción refinada para techos contemporáneos.

RU Световое пятно. Attica, встраиваемый заподлицо светильник для подвесных потолков, благодаря сочетанию фиксированного и регулируемого угла освещения может создавать как вертикальный, так и направленный поток света, для освещения определенных деталей интерьера. Изысканное решение для современных подвесных потолков.

Material / Materiale / Material / Material / Material / Material

Plaster / Gesso / Gips / Yeso / Гипсовый

Finish / Finitura / Fertigstellen / Terminar / закончить

White / Bianco / Weiß / Blanco / белый

Light source / Fonte di luce / Lichtquelle / Fuente de luz / Источник света

GU10 x 40W

Type-approvals / Omologazioni / Zulassungen / Homologaciones / Разрешения



Once installed in the plasterboard, it is flush with the ceiling and it can be painted over.

Dopo averlo installato nel cartongesso risulta parte integrante del soffitto e può essere tinteggiato.
Nach dem Einbau in Gipskartonplatten ist es ein integraler Bestandteil der Decke und kann gestrichen werden.
Tras su instalación en pladur, forma parte integrante del techo y puede pintarse.
После установки в гипсокартон становится составной частью потолка и может быть окрашен.



Example of painted product
Esempio di prodotto verniciato
Beispiel für das gestrichene Produkt
Ejemplo de producto pintado
Пример окрашенного прибора



←↓
T28 Attica Glass
Invisible recessed fitting for false ceilings
GU10 – 1x40W
w70 x d70 mm lighted hole



↑→
T04 Attica
Recessed plaster spotlight
GU10 – 1x40W
w70 x d70 mm lighted hole



→
T177 Attica orientabile
Recessed plaster spotlight
with adjustable light point
GU10 – 1x40W
w70 x d70 mm lighted hole





Wall, ceiling and pendant lamps

Lampade da parete, a soffitto e a sospensione
 Wand-, decken- und aufhängungsleuchten
 Lámparas de pared, techo y colgantes
 Настенные, потолочные и подвесные светильники

A series of wall and ceiling plaster lighting fixtures, designed for different applications with multiple, coordinated light points.

IT Serie di apparecchi da parete e soffitto in gesso nati per soddisfare le diverse applicazioni con punti luce multipli e coordinati.

ES Serie de luminarias de pared y techo de yeso diseñadas para satisfacer diferentes aplicaciones con múltiples puntos de luz coordinados.

DE Serie von Wand - und Deckenleuchten aus Gips, die für verschiedene Anwendungen mit mehreren, aufeinander abgestimmten Lichtpunkten konzipiert sind.

RU линейка настенных и потолочных светильников из гипса для самого разнообразного применения, с несколькими скоординированными источниками света.

Propilei



T406 / T487
T407 / T488

_blank design studio

A refined detail that illuminates. The Propilei plaster suspension or ceiling light is a perfect cylinder, embellished with a protruding aluminum ring available in six colors. Combine two or more lamps to create an elegant composition.

IT Un raffinato dettaglio che illumina. La lampada in gesso a sospensione o a soffitto Propilei è un cilindro perfetto, impreziosito da un anello in alluminio sporgente disponibile in sei varianti colore. Combinando due o più lampade, si possono creare raffinate composizioni.

ES Un detalle refinado que ilumina. El colgante o plafón de yeso Propilei es un cilindro perfecto adornado con un aro de aluminio saliente y está disponible en seis colores. Combinando dos o más lámparas se pueden crear composiciones refinadas.

DE Ein raffiniertes Detail, das leuchtet. Die Pendel- oder Deckenleuchte Propilei aus Gips ist ein perfekter Zylinder, der mit einem hervorstehenden Aluminiumring verziert ist, der in sechs Farben erhältlich ist. Durch die Kombination von zwei oder mehr Lampen können raffinierte Kompositionen geschaffen werden.

RU Изысканная световая деталь. Гипсовый подвесной или потолочный светильник Propilei - это идеальный цилиндр в сочетании с благородным рельефным кольцом из алюминия, доступном в шести вариантах расцветки. Вы сможете создавать элегантные композиции, комбинируя два или более светильника.

Material / Materiale / Material / Material / Материал

Plaster and aluminium / Gesso e alluminio / Gips und Aluminium / Yeso y aluminio / Гипс и алюминий

Matte black / Nero opaco / Mattschwarz / Negro mate / матовый черный

Matte white / Bianco opaco / Matt Weiß / Blanco Mate / Мэтт Уайт

Brushed brass / Ottone spazzolato / Gebürstetes Messing / Latón cepillado / Матовая латунь

Finish / Finitura / Fertigstellen / Terminar / закончить

Brushed copper / Rame spazzolato / Gebürstetes Kupfer / Cobre cepillado / Матовая медь

Brushed aluminium / Alluminio spazzolato / Gebürstetes Aluminium / Aluminio cepillado / Матовый алюминий

Brushed bronze / Bronzo spazzolato / Gebürstete Bronze / Bronce cepillado / Матовая бронза

Light source / Fonte di luce / Lichtquelle / Fuente de luz / Источник света

GU10 x 40W

Type-approvals / Omologazioni / Zulassungen / Homologaciones / Разрешения





←↓
T406 Propilei
 Plaster suspension lamp with
 matte white painted ring finishing
 GU10 – 1x40W
 Cable 2 m
 Ø100 x h 70 mm
 (product supplied with 4 interchangeable rings:
 matte white, matte black, brushed brass, brushed copper)



↑→
T406 Propilei
 Plaster suspension lamp with
 matte black painted ring finishing
 GU10 – 1x40W
 Cable 2 m
 Ø100 x h70 mm
 (product supplied with 4 interchangeable rings:
 matte white, matte black, brushed brass, brushed copper)





T406 Propilei

Plaster suspension lamp with
brushed brass ring finishing
GU10 – 1x40W
Cable 2 m
Ø100 x h70 mm

(product supplied with 4 interchangeable rings:
matte white, matte black, brushed brass, brushed copper)



T406 Propilei

Plaster suspension lamp with
brushed copper ring finishing
GU10 – 1x40W
Cable 2 m
Ø100 x h70 mm

(product supplied with 4 interchangeable rings:
matte white, matte black, brushed brass, brushed copper)





↑→
T487 Propilei
 Plaster suspension lamp with
 brushed aluminium ring finishing
 GU10 – 1x40W
 Cable 2 m
 Ø100 x h70 mm
 (product supplied with 2 interchangeable rings:
 brushed aluminium, brushed bronze)



←↓
T487 Propilei
 Plaster suspension lamp with
 brushed bronze ring finishing
 GU10 – 1x40W
 Cable 2 m
 Ø100 x h70 mm
 (product supplied with 2 interchangeable rings:
 brushed aluminium, brushed bronze)





T407 Propilei

Plaster ceiling lamp with
matte black painted ring finishing
GU10 – 1x40W
Ø100 x h70 mm
(product supplied with 4 interchangeable rings:
matte white, matte black, brushed brass, brushed copper)



T407 Propilei

Plaster ceiling lamp with
matte white painted ring finishing
GU10 – 1x40W
Ø100 x h70 mm
(product supplied with 4 interchangeable rings:
matte white, matte black, brushed brass, brushed copper)





↑ →
T407 Propilei
 Plaster ceiling lamp with
 brushed brass ring finishing
 GU10 – 1x40W
 Ø100 x h70 mm
 (product supplied with 4 interchangeable rings:
 matte white, matte black, brushed brass, brushed copper)



← ↓
T407 Propilei
 Plaster ceiling lamp with
 brushed copper ring finishing
 GU10 – 1x40W
 Ø100 x h70 mm
 (product supplied with 4 interchangeable rings:
 matte white, matte black, brushed brass, brushed copper)



↓ →
T488 Propilei
 Plaster ceiling lamp with
 brushed aluminium ring finishing
 GU10 – 1x40W
 Ø100 x h70 mm
 (product supplied with 2 interchangeable rings:
 brushed aluminium, brushed bronze)



← ↑
T488 Propilei
 Plaster ceiling lamp with
 brushed bronze ring finishing
 GU10 – 1x40W
 Ø100 x h70 mm
 (product supplied with 2 interchangeable rings:
 brushed aluminium, brushed bronze)





Nasso quadrata



T426 / T427 / T428 / T429
T434 / T435 / T436 / T437

_blank design studio

Function and decoration. Nasso Square version is a plaster ceiling or wall lamp. It stands out as a source of light and a fascinating decorative element. The purity of its shapes and the different finishes make it versatile in any environment.

IT Funzione e decoro. Nasso Quadrata, lampada in gesso da soffitto o parete, si distingue come fonte di luce e affascinante elemento decorativo. La purezza delle sue forme e le diverse finiture la rendono versatile in ogni ambiente.

DE Funktion und Dekor. Nasso Quadrata, eine Decken- oder Wandleuchte aus Gips, besticht als Lichtquelle und faszinierendes Dekorationselement. Die Reinheit der Formen und die verschiedenen Ausführungen machen ihn in jeder Umgebung vielseitig einsetzbar.

Material / Materiale / Material / Material / Material / Material / Material

Finish / Finitura / Fertigstellen / Terminar / закончить

Light source / Fonte di luce / Lichtquelle / Fuente de luz / Источник света

Type-approvals / Omologazioni / Zulassungen / Homologaciones / Разрешения

ES Función y decoración. Nasso Quadrata, plafón o aplique de yeso, destaca como fuente de luz y elemento decorativo fascinante. La pureza de sus formas y sus diferentes acabados lo hacen versátil en cualquier ambiente.

RU Функциональность и декор. Гипсовый потолочный или настенный светильник Nasso в квадратном исполнении - это не только источник освещения, но и очаровательный декоративный элемент. Чистота форм и различные варианты отделки делают светильник универсальным и адаптируемым под любой интерьер.

Plaster and aluminium / Gesso e alluminio / Gips und Aluminium / Yeso y aluminio / Гипс и алюминий

Matte black / Nero opaco / Mattschwarz / Negro mate / матовый черный

Matte white / Bianco opaco / Matt Weiß / Blanco Mate / Мэтт Уайт

Brushed brass / Ottone spazzolato / Gebürstetes Messing / Latón cepillado / Матовая латунь

Brushed copper / Rame spazzolato / Gebürstetes Kupfer / Cobre cepillado / Матовая медь

GX53 x 10W



↓ →
T426 Nasso
 Plaster ceiling lamp with
 matte black painted frame finishing
 GX53 - 1x10W
 w120 x d120 x h70 mm



← ↑
T427 Nasso
 Plaster ceiling lamp with
 matte white painted frame finishing
 GX53 - 1x10W
 w120 x d120 x h70 mm

↓→
T428 Nasso
 Plaster ceiling lamp with
 brushed brass frame finishing
 GX53 – 1x10W
 w120 x d120 x h70 mm



←↑
T429 Nasso
 Plaster ceiling lamp with
 brushed copper frame finishing
 GX53 – 1x10W
 w120 x d120 x h70 mm





↑→
T434 Nasso
 Plaster wall lamp for indirect lighting
 with matte black painted frame finishing
 GX53 – 1x10W
 w120 x d120 x h80 mm



←↓
T435 Nasso
 Plaster wall lamp for indirect lighting
 with matte white painted frame finishing
 GX53 – 1x10W
 w120 x d120 x h80 mm





↓ →
T436 Nasso
 Plaster wall lamp for indirect lighting
 with brushed brass frame finishing
 GX53 - 1x10W
 w120 x d120 x h80 mm



← ↑
T437 Nasso
 Plaster wall lamp for indirect lighting
 with brushed copper frame finishing
 GX53 - 1x10W
 w120 x d120 x h80 mm

Nasso tonda



T422 / T423 / T424 / T425
T430 / T431 / T432 / 433

_blank design studio

Function in its purest form. Plaster ceiling or wall lamp. Its perfect roundness is emphasized by an aluminum ring, and it becomes a precious detail in any environment. Nasso Round version is available in four colors to match any architectural finish.

IT Funzione nella sua forma più pura. Lampada in gesso da soffitto o parete. La sua perfetta circolarità viene sottolineata da un anello in alluminio e dona un dettaglio prezioso in ogni ambiente. Nasso Tonda è disponibile in quattro colorazioni che possono sposare ogni tipo di finitura architettonale.

DE Funktion in ihrer reinsten Form. Decken - oder Wandleuchte aus Gips. Seine perfekte Rundung wird durch einen Aluminiumring hervorgehoben und verleiht jeder Umgebung ein kostbares Detail. Nasso Tonda ist in vier Farben erhältlich, die sich an jede architektonische Oberfläche anpassen lassen.

ES Función en estado puro. Plafón o aplique de yeso. Su perfecta circularidad se acentúa con un aro de aluminio y confiere un detalle precioso a cualquier ambiente. Nasso Tonda está disponible en cuatro colores que pueden combinarse con cualquier acabado arquitectónico.

RU Функциональность в чистом виде. Гипсовый потолочный или настенный светильник. Светильник, чья идеально круглая форма дополнительно подчеркивается алюминиевым кольцом, внесет благородный штрих в любой интерьер. Nasso в круглом исполнении выпускается в четырех расцветках, благодаря чему вы сможете подобрать вариант, наиболее подходящий к цветам отделки вашей комнаты.

Material / Materiale / Material / Material / Material

Plaster and aluminium / Gesso e alluminio / Gips und Aluminium / Yeso y aluminio / Гипс и алюминий

Finish / Finitura / Fertigstellen / Terminar / закончить

Matte black / Nero opaco / Mattschwarz / Negro mate / матовый черный

Matte white / Bianco opaco / Matt Weiß / Blanco Mate / Мэтт Уайт

Brushed brass / Ottone spazzolato / Gebürstetes Messing / Latón cepillado / Матовая латунь

Brushed copper / Rame spazzolato / Gebürstetes Kupfer / Cobre cepillado / Матовая медь

Light source / Fonte di luce / Lichtquelle / Fuente de luz / Источник света

GX53 x 10W

Type-approvals / Omologazioni / Zulassungen / Homologaciones / Разрешения





↑→
T422 Nasso
 Plaster ceiling lamp with
 matte black painted ring finishing
 GX53 - 1x10W
 Ø120 x h70 mm



←↓
T423 Nasso
 Plaster ceiling lamp with
 matte white painted ring finishing
 GX53 - 1x10W
 Ø120 x h70 mm



↓ →
T424 Nasso
 Plaster ceiling lamp with
 brushed brass ring finishing
 GX53 – 1x10W
 Ø120 x h70 mm



← ↓
T425 Nasso
 Plaster ceiling lamp with
 brushed copper ring finishing
 GX53 – 1x10W
 Ø120 x h70 mm





↓ →
T430 Nasso
 Plaster wall lamp for indirect lighting
 with matte black painted ring finishing
 GX53 - 1x10W
 Ø120 x h80 mm



← ↑
T431 Nasso
 Plaster wall lamp for indirect lighting
 with matte white painted ring finishing
 GX53 - 1x10W
 Ø120 x h80 mm



↑→
T432 Nasso
 Plaster wall lamp for indirect lighting
 with brushed brass ring finishing
 GX53 – 1x10W
 Ø120 x h80 mm



←↓
T433 Nasso
 Plaster wall lamp for indirect lighting
 with brushed copper ring finishing
 GX53 – 1x10W
 Ø120 x h80 mm



Syme quadrata



T442 / T443 / T444 / T445
T450 / T451 / 452 / T453

_blank design studio

The refinement of essential forms. Plaster wall or ceiling lamp, in the square version, it features a protruding aluminium frame that emphasises its pure forms. With single-light in the ceiling version, or double light in the wall-mounted version, Syme offers timeless elegance.

IT La raffinatezza delle forme essenziali. Lampada in gesso per parete o soffitto, nella variante quadrata, presenta una cornice in alluminio sporgente che enfatizza le sue forme pure. Con emissione singola a soffitto o doppia emissione per la versione a parete, Syme regala un'eleganza senza tempo.

DE Die Verfeinerung der wesentlichen Formen. Die quadratische Variante der Gipsleuchte für Wand oder Decke hat einen hervorstehenden Aluminiumrahmen, der die reinen Formen betont. Mit einfachem Lichtaustritt für die Decke oder doppeltem Lichtaustritt für die Wandmontage bietet Syme zeitlose Eleganz.

ES El refinamiento de las formas esenciales. Lámpara de yeso para pared o techo, en la variante cuadrada, presenta un marco de aluminio saliente que acentúa sus formas puras. Con emisión simple para el techo o doble para la versión de pared, Syme ofrece una elegancia atemporal.

RU Изысканность лаконичных форм. Гипсовый настенный или потолочный светильник в квадратном исполнении комплектуется рельефной алюминиевой рамкой, которая подчеркивает его чистую форму. Syme в потолочной версии с однонаправленным свечением либо в настенной версии с двунаправленным свечением дарит неподвластную времени элегантность.

Material / Materiale / Material /
Material / Материал

Plaster and aluminium / Gesso e
alluminio / Gips und Aluminium /
Yeso y aluminio / Гипс и алюминий

Finish / Finitura / Fertigstellen /
Terminar / закончить

Matte black / Nero opaco / Matt-
schwarz / Negro mate / матовый
черный

Matte white / Bianco opaco / Matt
Weiß / Blanco Mate / Мэтт Уайт

Brushed brass / Ottone spazzolato /
Gebürstetes Messing / Latón
cepillado / Матовая латунь

Brushed copper / Rame
spazzolato / Gebürstetes Kupfer /
Cobre cepillado / Матовая медь

Light source / Fonte di luce /
Lichtquelle / Fuente de luz /
Источник света

GX53 x 10W

Type-approvals / Omologazioni /
Zulassungen / Homologaciones /
Разрешения





↑→
T442 Syme
 Plaster ceiling lamp with
 matte black painted frame finishing
 GX53 - 1x10W
 w110 x d110 x h80 mm



←↓
T443 Syme
 Plaster ceiling lamp with
 matte white painted frame finishing
 GX53 - 1x10W
 w110 x d110 x h80 mm

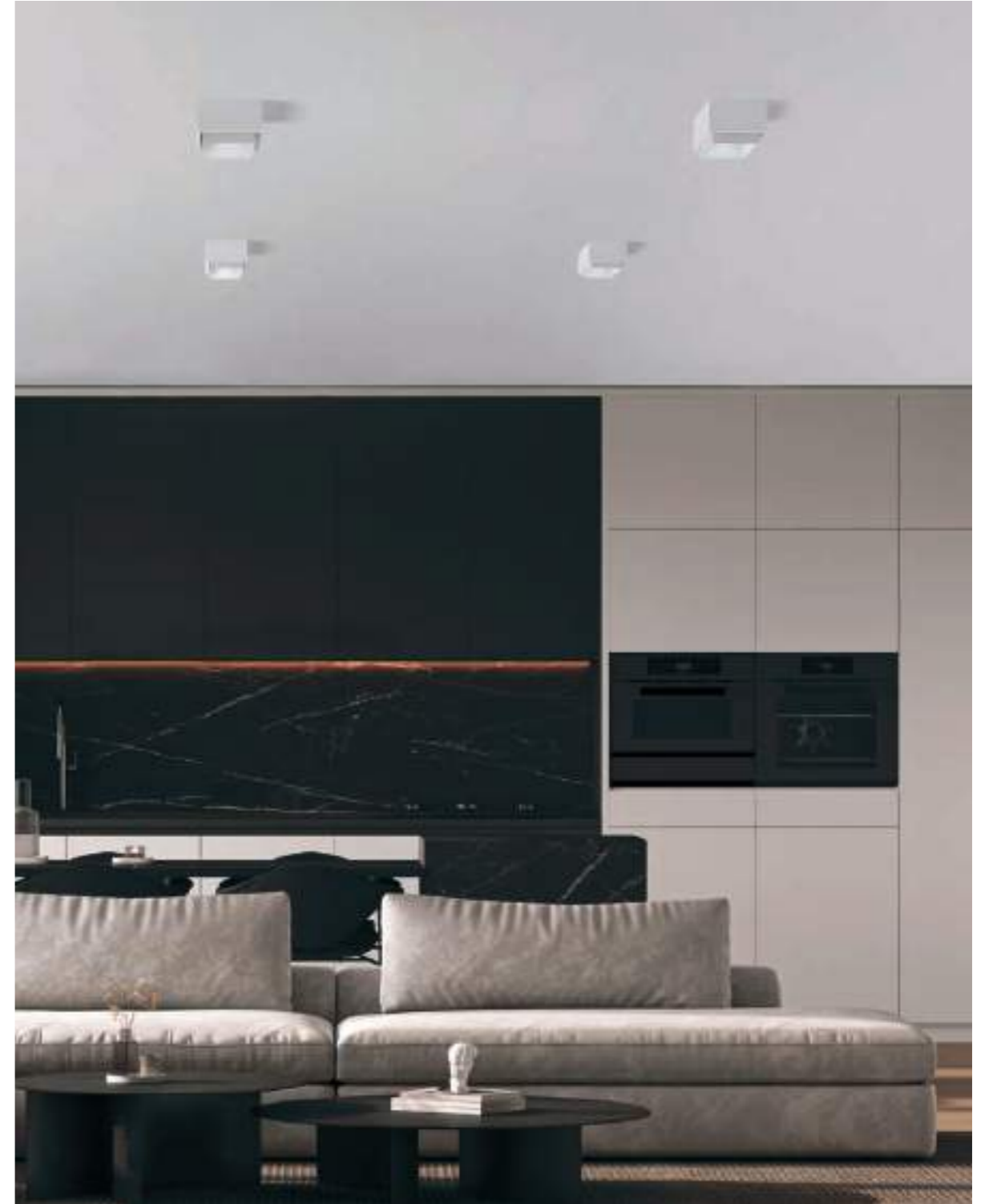

↓ →
T444 Syme
 Plaster ceiling lamp with
 brushed brass frame finishing
 GX53 – 1x10W
 w110 x d110 x h80 mm



← ↑
T445 Syme
 Plaster ceiling lamp with
 brushed copper frame finishing
 GX53 – 1x10W
 w110 x d110 x h80 mm





↓→
T450 Syme
 Plaster wall lamp with
 matte black painted frame finishing
 GX53 – 2x10W
 w110 x d130 x h150 mm



←↓
T451 Syme
 Plaster wall lamp with
 matte white painted frame finishing
 GX53 – 2x10W
 w110 x d130 x h150 mm



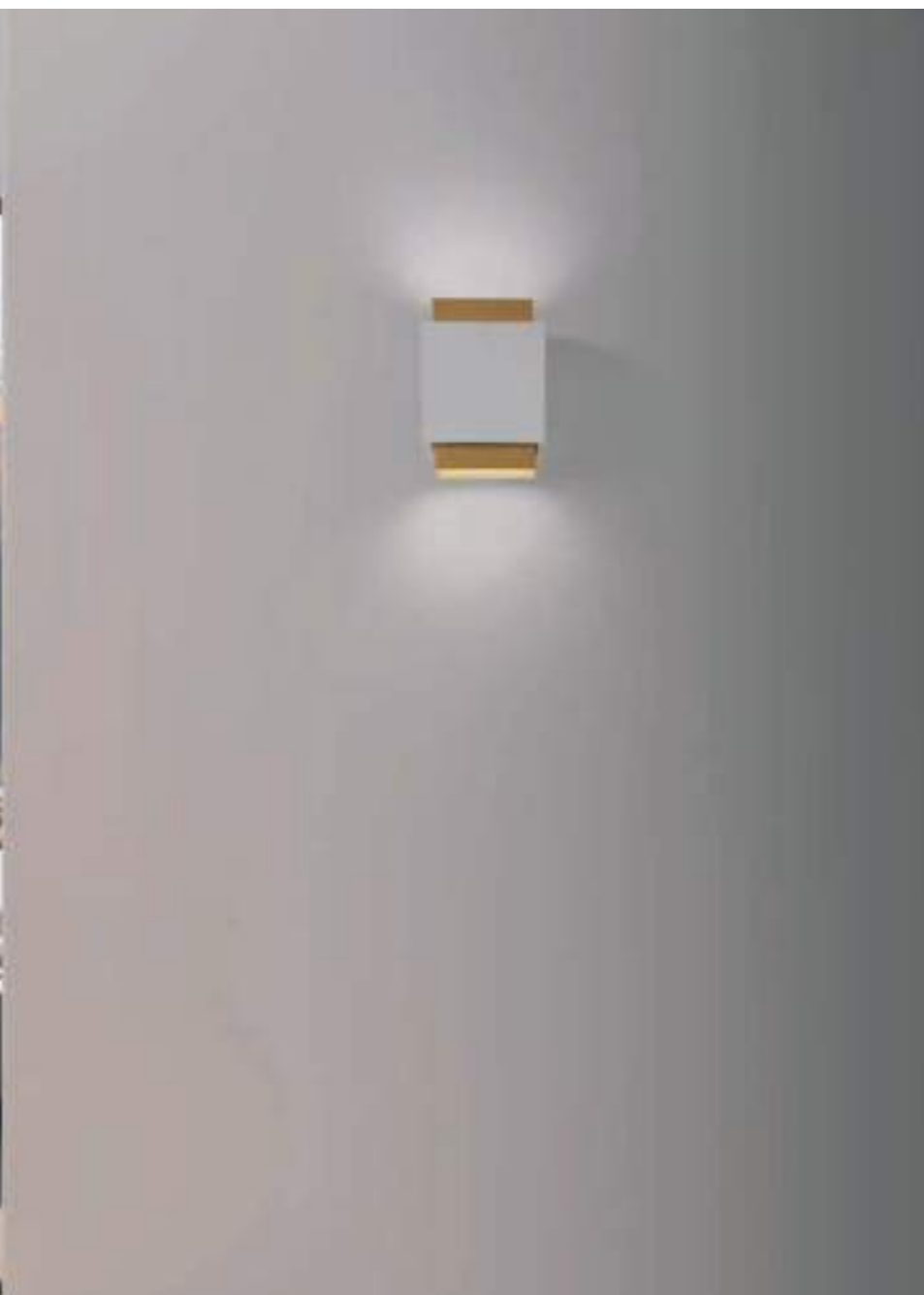

↓ →
T452 Syme
 Plaster wall lamp with
 brushed brass frame finishing
 GX53 - 2x10W
 w110 x d130 x h150 mm



← ↑
T453 Syme
 Plaster wall lamp with
 brushed copper frame finishing
 GX53 - 2x10W
 w110 x d130 x h150 mm



Syme tonda



T438 / T439 / T440 / T441
T446 / T447 / T448 / T449

_blank design studio

Elegant and refined shapes. Syme - plaster wall or ceiling lamp - in its cylindrical version is characterised by a projecting aluminium ring that emphasises its roundness. With single-light in the ceiling version, or double light in the wall-mounted version, Syme offers timeless elegance.

IT Forme eleganti e raffinate. Syme, lampada in gesso per parete o soffitto, nella variante cilindrica è caratterizzata da un anello in alluminio sporgente che ne enfatizza la circolarità. Con emissione singola a soffitto o doppia emissione per la versione a parete, Syme regala un'eleganza senza tempo.

DE Elegante und raffinierte Formen. Syme, eine Wand- oder Deckenleuchte aus Gips, zeichnet sich in ihrer zylindrischen Version durch einen vortretenden Aluminiumring aus, der ihre Kreisform unterstreicht. Mit einfachem Lichtaustritt für die Decke oder doppeltem Lichtaustritt für die Wand, bietet Syme zeitlose Eleganz.

ES Formas elegantes y refinadas. Syme, lámpara de yeso para pared o techo, en su versión cilíndrica se caracteriza por un anillo saliente de aluminio que acentúa su circularidad. Con emisión simple para el techo o doble para la versión de pared, Syme ofrece una elegancia atemporal.

RU Элегантные и утонченные формы. Гипсовый настенный или потолочный светильник Syme в цилиндрической версии комплектуется выпуклым алюминиевым кольцом, подчеркивающим его круглую форму. Syme в потолочной версии с однонаправленным свечением либо в настенной версии с двунаправленным свечением дарит вечно актуальную элегантность.

Material / Materiale / Material / Material / Material / Material / Material

Plaster and aluminium / Gesso e alluminio / Gips und Aluminium / Yeso y aluminio / Гипс и алюминий

Finish / Finitura / Fertigstellen / Terminar / закончить

Matte black / Nero opaco / Mattschwarz / Negro mate / матовый черный

Matte white / Bianco opaco / Mattweiß / Blanco Mate / Мэтт Уайт

Brushed brass / Ottone spazzolato / Gebürstetes Messing / Latón cepillado / Матовая латунь

Brushed copper / Rame spazzolato / Gebürstetes Kupfer / Cobre cepillado / Матовая медь

Light source / Fonte di luce / Lichtquelle / Fuente de luz / Источник света

GX53 x 10W

Type-approvals / Omologazioni / Zulassungen / Homologaciones / Разрешения



↓ →
T438 Syme
 Plaster ceiling lamp with
 matte black painted ring finishing
 GX53 - 1x10W
 Ø110 x h80 mm



← ↑
T439 Syme
 Plaster ceiling lamp with
 matte white painted ring finishing
 GX53 - 1x10W
 Ø110 x h80 mm





← ↓
T441 Syme
Plaster ceiling lamp with
brushed copper ring finishing
GX53 – 1x10W
Ø110 x h80 mm



↑ →
T440 Syme
Plaster ceiling lamp with
brushed brass ring finishing
GX53 – 1x10W
Ø110 x h80 mm





↑ → →

T446 Syme

Plaster wall lamp with
matte black painted ring finishing
GX53 – 2x10W
w110 x d130 x h146 mm



← ← ↓

T447 Syme

Plaster wall lamp with
matte white painted ring finishing
GX53 – 2x10W
w110 x d130 x h146 mm



↓ → →
T448 Syme
 Plaster wall lamp with
 brushed brass ring finishing
 GX53 – 2x10W
 w110 x d130 x h146 mm



← ← ↑
T449 Syme
 Plaster wall lamp with
 brushed copper ring finishing
 GX53 – 2x10W
 w110 x d130 x h146 mm



Mysia



T454 / T455 / T456 / T457 / T458 / T459
T460 / T461 / T477 / T462 / T463 / T478

Acero design studio

Sinuous wholeness. The Mysia plaster wall or ceiling lamp, available with one, two or three lights, features soft lines that gently envelops the light points. The lamp fixture is available in two colours.

IT Sinuosa integrità. La lampada in gesso da parete o soffitto Mysia, disponibile nelle versioni ad una, due o tre luci, con le sue linee morbide avvolge delicatamente i punti luce. Il corpo lampada è disponibile con finitura a scelta in due colorazioni.

ES Integridad sinuosa. El aplique o plafón Mysia, disponible en versiones de una, dos o tres luces, con sus suaves líneas envuelve suavemente los puntos de luz. El cuerpo de la lámpara está disponible en dos colores.

DE Gewundene Integrität. Die Wand - oder Deckenleuchte Mysia, die in ein-, zwei- oder dreiflammiger Ausführung erhältlich ist, umhüllt mit ihren weichen Linien sanft die Lichtpunkte. Der Körper der Leuchte ist in zwei Farben erhältlich.

RU Плавная завершенность. Гипсовый настенный или потолочный светильник Mysia предлагается в версиях с одним, двумя или тремя источниками света, которые мягко обрамляются плавными линиями корпуса. Корпус светильника предлагается в двух разных цветах на выбор.

Material / Materiale / Material / Material / Material / Material

Plaster / Gesso / Gips / Yeso / Гипсовый

Finish / Finitura / Fertigstellen / Terminar / закончить

White / Bianco / Weiß / Blanco / Белый

Quartz grey / Grigio quarzo / Quarzgrau / Gris cuarzo / Кварц серый

Light source / Fonte di luce / Lichtquelle / Fuente de luz / Источник света

GX53 x 10W

Type-approvals / Omologazioni / Zulassungen / Homologaciones / Разрешения





←←↓
T455 Mysia
 Two-lights plaster ceiling lamp
 GX53 - 2x10W
 w200 x d110 x h75 mm

↑→
T454 Mysia
 One-light plaster ceiling lamp
 GX53 - 1x10W
 Ø110 x h75 mm



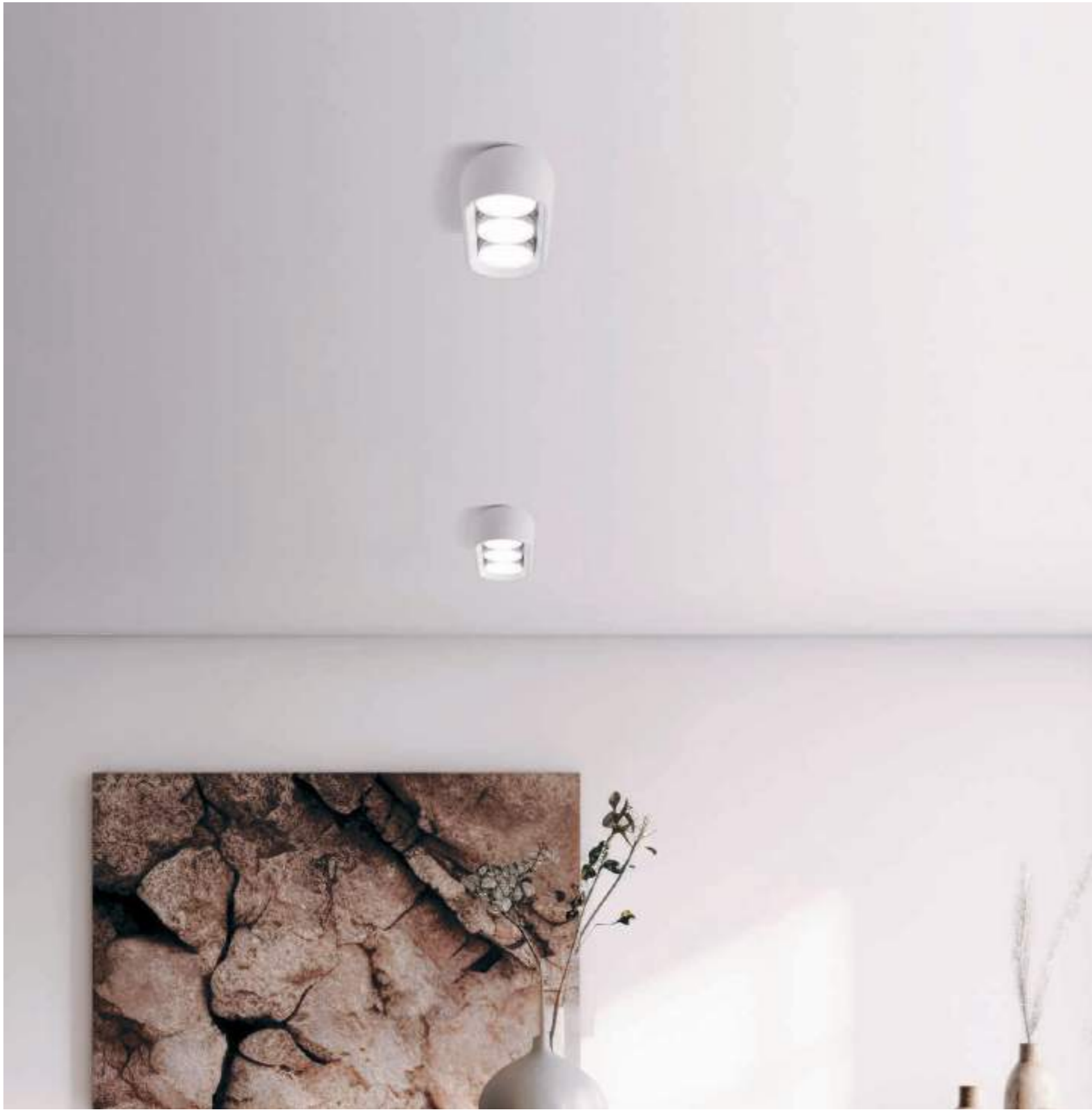

↙↘
T456 Mysia
Three-lights plaster ceiling lamp
GX53 – 3x10W
w280 x d110 x h75 mm



↓→
T457 Mysia
 One-light plaster ceiling lamp
 GX53 – 1x10W
 Ø110 x h75 mm



←↓
T458 Mysia
 Two-lights plaster ceiling lamp
 GX53 – 2x10W
 w200 x d110 x h75 mm

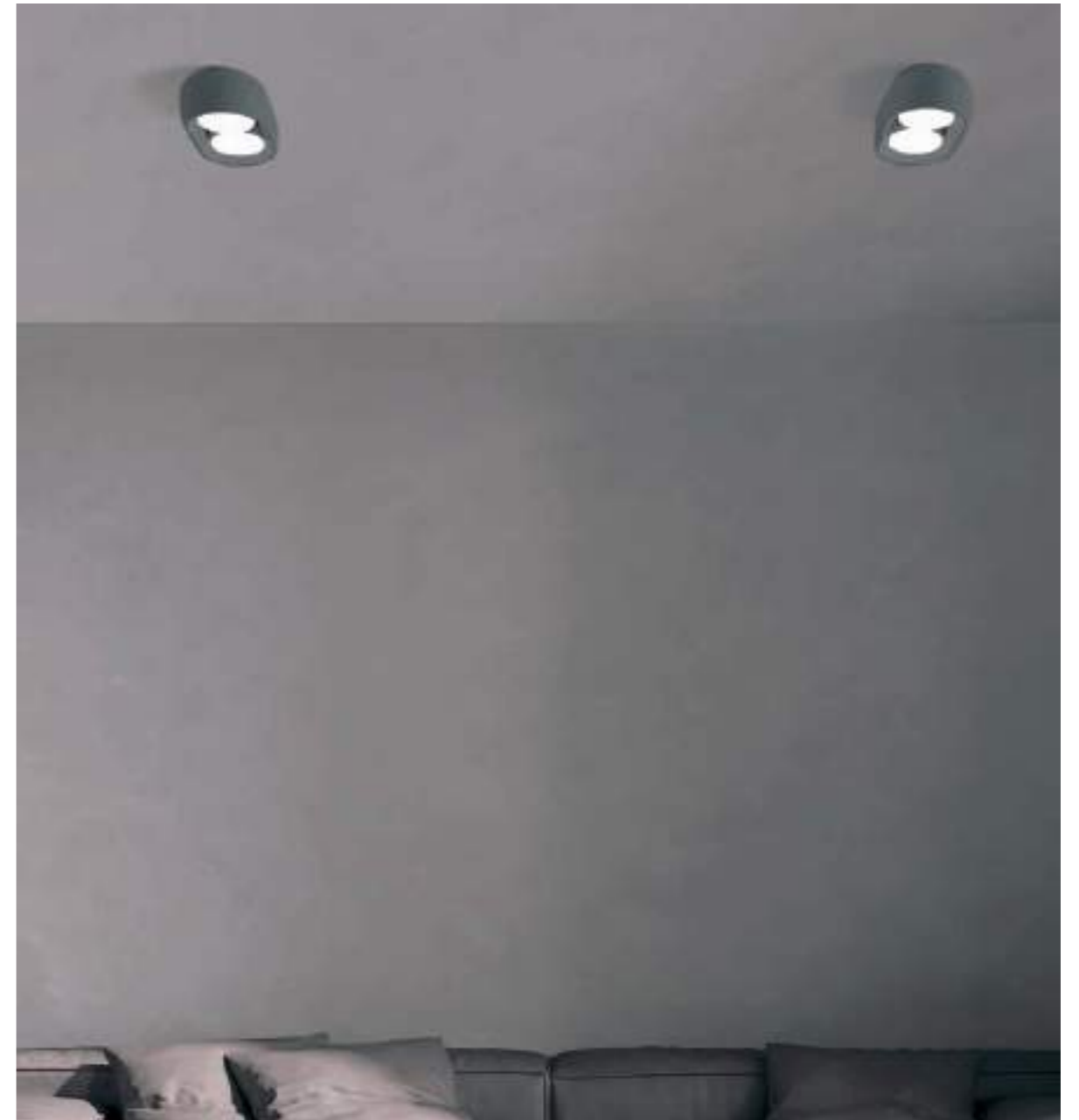



↑→
T459 Mysia
Three-lights plaster ceiling lamp
GX53 – 3x10W
w280 x d110 x h75 mm



| Wall, ceiling and pendant



↓ →
T460 Mysia
 One-light plaster wall lamp
 GX53 – 1x10W
 w110 x d120 x h75 mm



← ↑
T461 Mysia
 Two-lights plaster wall lamp
 GX53 – 2x10W
 w200 x d120 x h75 mm



↓↓→
T477 Mysis
Three-lights plaster wall lamp
GX53 - 3x10W
w275 x d120 x h75 mm



↓ →
T462 Mysia
 One-light plaster wall lamp
 GX53 – 1x10W
 w110 x d120 x h75 mm



← ↑
T463 Mysia
 Two-lights plaster wall lamp
 GX53 – 2x10W
 w200 x d120 x h75 mm





←↓↓↓
T478 Mysia
Three-lights plaster wall lamp
CX53 – 3x10W
w275 x d120 x h75 mm



Milet



T472 / T473 /
T474 / T475 / T476

_blank design studio

A refined detail that emphasises shapes. Milet - available in various wall- and ceiling-mounted solutions - blends perfectly into any room, giving it a modern accent. Available with one, two or four lights, the painted aluminium element emphasises its geometric and rigorous structure.

IT Un dettaglio ricercato che sottolinea le forme. Milet, disponibile in diverse soluzioni sia da parete che da soffitto, si inserisce nell'ambiente dando un accento di modernità. Disponibile in varianti da una, due o quattro luci, l'elemento in alluminio verniciato ne enfatizza la struttura geometrica e rigorosa.

ES Un detalle refinado que realza las formas. Milet, que está disponible en varias soluciones de pared y techo, se integra en el ambiente y le da un acento moderno. Disponible en variantes de una, dos o cuatro luces, el elemento de aluminio pintado resalta su estructura geométrica y rigurosa.

DE Ein raffiniertes Detail, das die Formen unterstreicht. Milet, das in verschiedenen Wand- und Deckenlösungen erhältlich ist, fügt sich in den Raum ein und verleiht ihm einen modernen Akzent. Das lackierte Aluminiumelement, das in Varianten mit einer, zwei oder vier Leuchten erhältlich ist, unterstreicht seine geometrische und strenge Struktur.

RU Изысканная деталь, подчеркивающая формы. Светильник Milet, предлагаемый в различных настенных и потолочных версиях, гармонично вписывается в интерьер, принося современные ноты. Светильник в вариантах с одним, двумя или четырьмя источниками света, имеет геометрически строгий корпус, лаконичность которого подчеркивается декоративным элементом из окрашенного алюминия.

Material / Materiale / Material / Material / Material / Material / Material

Plaster and aluminium / Gesso e alluminio / Gips und Aluminium / Yeso y aluminio / Гипс и алюминий

Finish / Finitura / Fertigstellen / Terminar / закончить

White / Bianco / Weiß / Blanco / Белый

Quartz grey / Grigio quarzo / Quarzgrau / Gris cuarzo / Кварц серый

Light source / Fonte di luce / Lichtquelle / Fuente de luz / Источник света

CX53 x 10W

Type-approvals / Omologazioni / Zulassungen / Homologaciones / Разрешения





↓→
T472 Milet
 Plaster wall lamp with Quartz Grey
 (RAL 7039) painted aluminium element
 GX53 – 1x10W
 w180 x d152 x h50 mm



←↑
T473 Milet
 Plaster wall lamp with Quartz Grey
 (RAL 7039) painted aluminium element
 GX53 – 2x10W
 w320 x d155 x h80 mm

↓→
T474 Milet
 Plaster ceiling lamp with Quartz Grey
 (RAL 7039) painted aluminium elements
 GX53 – 1x10W
 w153 x d160 x h50 mm

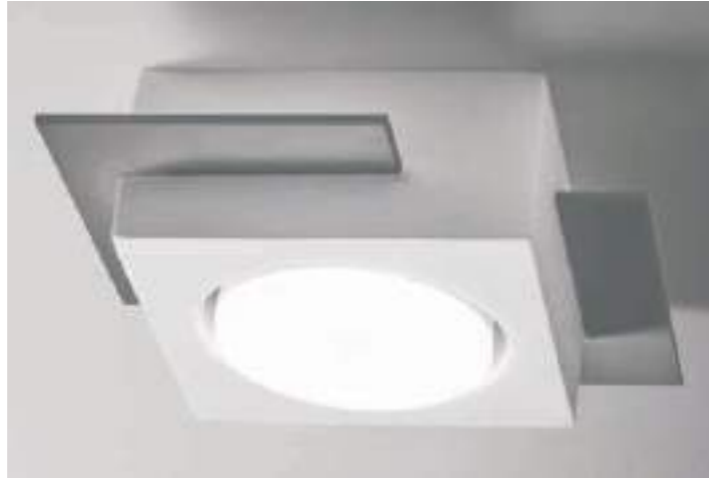

←↓
T475 Milet
 Plaster ceiling lamp with Quartz Grey
 (RAL 7039) painted aluminium elements
 GX53 – 2x10W
 w245 x d180 x h50 mm





T476 Milet

Plaster ceiling lamp with Quartz Grey
(RAL 7039) painted aluminium elements
CX53 - 4x10W
w330 x d305 x h50 mm



Cicladi tonda



T403 / T404 / T405

_blank design studio

Harmonious roundness. Cicladi (Round) - plaster and glass ceiling or wall lamp - stands out for its timeless elegance. Available with one or multiple lights. Each lighting element has a round blown glass diffuser that creates a soft and pleasant light.

IT Armoniosa circolarità.

Cicladi tonda, lampada a soffitto o parete in gesso e vetro, si distingue per la sua eleganza senza tempo. Disponibile ad una o più luci. Ogni elemento illuminante dispone di un diffusore rotondo in vetro soffiato che crea un'illuminazione morbida e piacevole.

DE Harmonische Zirkularität.

Cicladi tonda, eine Decken- oder Wandleuchte aus Gips und Glas, zeichnet sich durch ihre zeitlose Eleganz aus. Erhältlich mit einer oder mehreren Leuchten. Jedes Leuchtelement hat einen runden Diffusor aus geblasenem Glas, der eine weiche und angenehme Beleuchtung erzeugt.

ES Circularidad armoniosa.

Cicladi tonda, lámpara de techo o aplique de yeso y cristal, se distingue por su elegancia atemporal. Disponible con una o varias luces. Cada elemento de iluminación tiene un difusor redondo de vidrio soplado que crea una iluminación suave y agradable.

RU Гармоничная округлость.

Потолочный или настенный светильник Cicladi в круглом исполнении, выполненный из гипса и стекла, отличается неподвластной времени элегантностью. Имеются варианты с одним или несколькими источниками света. Каждый световой элемент комплектуется круглым рассеивателем из выдувного стекла, который создает мягкое и приятное освещение.

Material / Materiale / Material /
Material / Материал

Plaster and glass / Gesso e
vetro / Gips und Glas / Yeso y
vidrio / Гипс и стекло

Finish / Finitura / Fertigstellen /
Terminar / закончить

White / Bianco / Weiß / Blanco /
Белый

Light source / Fonte di luce /
Lichtquelle / Fuente de luz /
Источник света

GX53 x 10W

Type-approvals / Omologazioni /
Zulassungen / Homologaciones /
Разрешения





↑→
T403 Cicladi
Plaster ceiling/wall lamp
with one round blown glass
GX53 – 1x10W
Ø230 x h130 mm



←↓
T404 Cicladi
Plaster ceiling/wall lamp
with two round blown glass
GX53 – 2x10W
w410 x d245 x h130 mm





T405 Cicladi

Plaster ceiling/wall lamp with three round blown glass
GX53 - 3x10W
w400 x d400 x h135 mm

Cicladi



T385 / T386 / T396
T387 / T388 / T389

_blank design studio

Delicate balance of volumes. The Cicladi plaster wall and ceiling lamp, with round blown glass diffuser, is available in one-, two- or three-light configurations, to meet different diffuse lighting needs. Its peculiar feature is the irregularly shaped base that supports the diffuser, creating an interplay of balances and contrasts.

IT Delicato equilibrio di volumi.

La lampada a parete e a soffitto in gesso Cicladi, con diffusore sferico in vetro soffiato, è disponibile in configurazioni a una, due o tre luci andando incontro a diverse esigenze di illuminazione diffusa. La base di forma irregolare, sostenendo il diffusore, crea un interessante gioco di bilanciamenti e contrasti che sono il suo carattere distintivo.

DE Ausgewogenes Gleichgewicht der Volumen.

Die Wand- und Deckenleuchte Cicladi aus Gips mit einem kugelförmigen Diffusor aus mundgeblasenem Glas ist in ein-, zwei- oder dreiflämmiger Ausführung erhältlich, um unterschiedlichen Anforderungen an eine diffuse Beleuchtung gerecht zu werden. Der unregelmäßig geformte Sockel, der den Diffusor trägt, schafft ein Zusammenspiel von Gleichgewichten und Kontrasten, die sein besonderes Merkmal sind.

ES Delicado equilibrio de volúmenes.

El aplique y plafón de yeso Cicladi, con difusor esférico de vidrio soplado, está disponible en configuraciones de una, dos o tres luces para satisfacer diferentes necesidades de iluminación difusa. La base de forma irregular, que soporta el difusor, crea un juego de equilibrios y contrastes que son su seña de identidad.

RU Изящный баланс объемов.

Гипсовый настенный и потолочный светильник Cicladi со сферическим рассеивателем из выдувного стекла предлагается в конфигурациях с одним, двумя или тремя источниками света, для удовлетворения различных потребностей в рассеянном освещении. Основание неправильной формы, на которое опирается рассеиватель, создает игру баланса и контраста, которая становится отличительной чертой этого светильника.

Material / Materiale / Material / Material / Материал

Plaster and glass / Gesso e vetro / Gips und Glas / Yeso y vidrio / Гипс и стекло

Finish / Finitura / Fertigstellen / Terminar / закончить

White / Bianco / Weiß / Blanco / Белый

Light source / Fonte di luce / Lichtquelle / Fuente de luz / Источник света

GX53 x10W

Type-approvals / Omologazioni / Zulassungen / Homologaciones / Разрешения

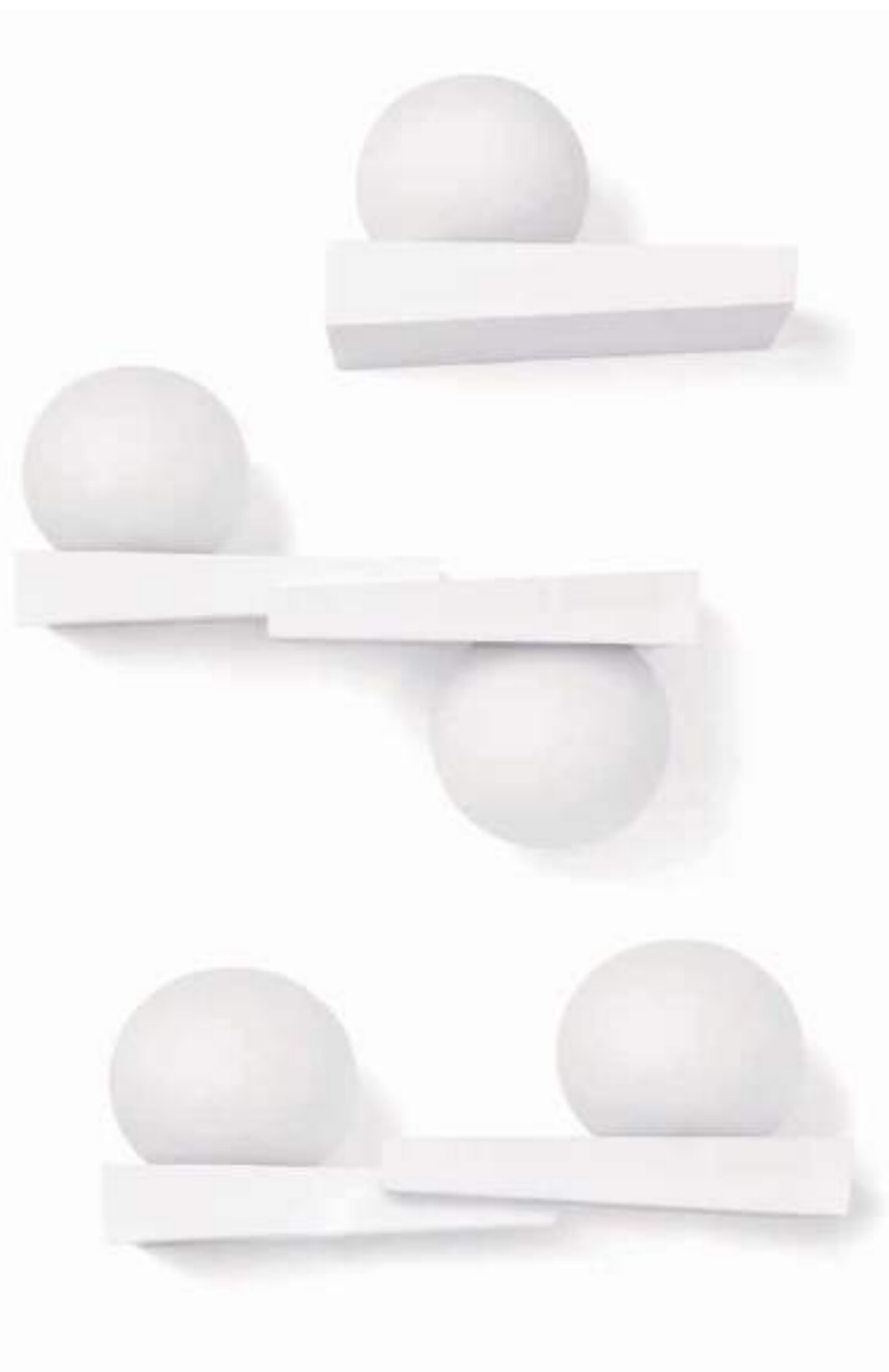



↓→
T385 Cicladi
Plaster wall lamp with one round blown glass
GX53 - 1x10W
w250 x d145 x h135 mm





↑→→
T386 Cicladi
Plaster wall lamp
with two round blown glass
GX53 - 2x10W
w430 x d170 x h155 mm



←↓
T396 Cicladi
Up/down lights plaster wall lamp
with two round blown glass
GX53 - 2x10W
w400 x d165 x h230 mm



↓ → →
T387 Cicladi
 Plaster ceiling lamp
 with one round blown glass
 GX53 - 1x10W
 w215 x d215 x h125 mm

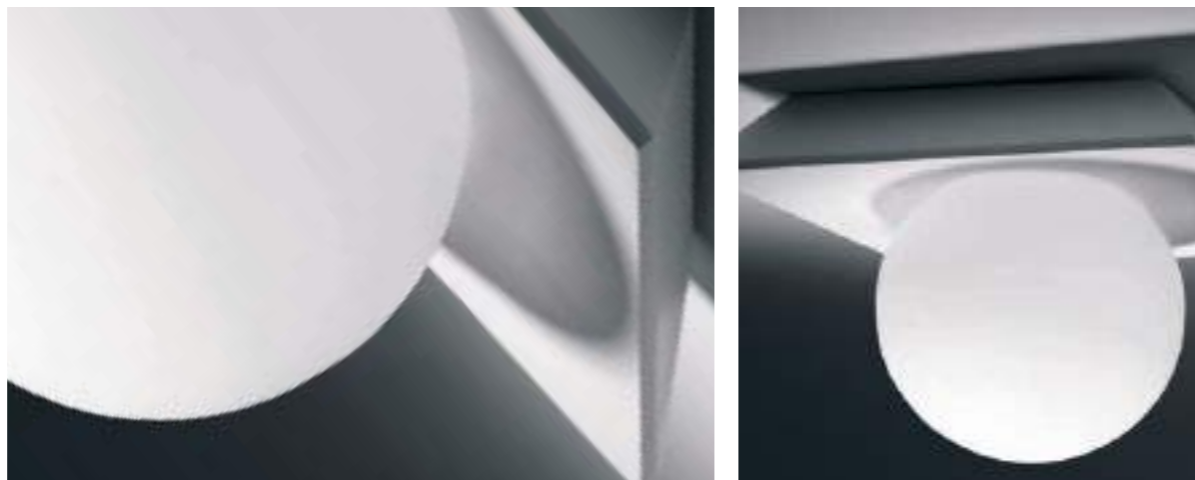

← ↑
T388 Cicladi
 Plaster ceiling lamp
 with two round blown glass
 GX53 - 2x10W
 w445 x d275 x h125 mm



↓↓→
T389 Cicladi
Plaster ceiling lamp
with three round blown glass
GX53 - 3x10W
w427 x d370 x h135 mm



Patra



T394 / T395

_blank design studio

Softness that draws light and shadows. Patra's - plaster wall lamp for indirect lighting - round structure elegantly conceals the light source, creating an enveloping atmosphere.

IT Morbidezza che disegna luci e ombre. La struttura circolare di Patra, lampada da parete in gesso per illuminazione indiretta, cela elegantemente la fonte luminosa creando un'atmosfera avvolgente.

ES Suavidad que dibuja luces y sombras. La estructura circular de Patra, un aplique de yeso para iluminación indirecta, oculta con elegancia la fuente de luz creando una atmósfera envolvente.

DE Weichheit, die Licht und Schatten zeichnet. Die kreisförmige Struktur von Patra, einer Wandleuchte aus Gips für indirekte Beleuchtung, verbirgt elegant die Lichtquelle und schafft eine einhüllende Atmosphäre.

RU Мягкость, рождающая свет и тени. Круглый корпус гипсового настенного светильника Patra, предназначенного для непрямого освещения, элегантно скрывает источник света, создавая обволакивающую атмосферу.

Material / Materiale / Material / Material / Материал

Plaster / Gesso / Gips / Yeso / Гипсовый

Finish / Finitura / Fertigstellen / Terminar / закончить

White / Bianco / Weiß / Blanco / Белый

Light source / Fonte di luce / Lichtquelle / Fuente de luz / Источник света

GX53 x 10W

Type-approvals / Omologazioni / Zulassungen / Homologaciones / Разрешения



↓ ↓ →
T394 Patra
 Plaster wall lamp for indirect lighting
 GX53 - 1x10W
 w180 x d133 x h137 mm





↓ → →
T395 Patra
Plaster wall lamp for indirect lighting
GX53 – 2x10W
w340 x d148 x h175 mm





Pitane



T399 / T400
T401 / T402

_blank design studio

Tradition and contemporaneity. Pitane - plaster and glass ceiling lamp - houses an opal glass diffuser set in the lamp fixture socket. Available with one, two or three lights, it elegantly evokes the forms of the past, reinterpreting them in a modern key.

IT Tradizione e contemporaneità. Pitane, lampada a soffitto in gesso e vetro, ospita un diffusore in vetro opalino incastonato nell'incavo del corpo lampada. Disponibile in versioni a una, due o tre luci, rievoca con eleganza le forme del passato, reinterpretandole in chiave moderna.

ES Tradición y contemporaneidad. Pitane, una lámpara de techo de yeso y cristal, alberga un difusor de cristal opalino encajado en el hueco del cuerpo de la lámpara. Disponible en versiones de una, dos o tres luces, evoca con elegancia las formas del pasado reinterpretándolas en clave moderna.

DE Tradition und Zeitgenossenschaft. Pitane, eine Deckenleuchte aus Gips und Glas, beherbergt einen Diffusor aus Opalglas, der in den Hohlraum des Körpers der Leuchte eingelassen ist. Erhältlich in Versionen mit einer, zwei oder drei Leuchten, erinnert sie auf elegante Weise an die Formen der Vergangenheit und interpretiert sie auf moderne Weise neu.

RU Традиции и современный дух. Потолочный светильник Pitane, выполненный из гипса и стекла, оснащен рассеивателем из опалового стекла, установленным в углублении корпуса. Светильники, предлагаемые в версии с одним, двумя или тремя источниками света, представляют собой элегантное переосмысление форм прошлого в современном ключе.

Material / Materiale / Material / Material / Материал

Plaster and glass / Gesso e vetro / Gips und Glas / Yeso y vidrio / Гипс и стекло

Finish / Finitura / Fertigstellen / Terminar / закончить

White / Bianco / Weiß / Blanco / Белый

Light source / Fonte di luce / Lichtquelle / Fuente de luz / Источник света

GX53 x 10W

Type-approvals / Omologazioni / Zulassungen / Homologaciones / Разрешения





↑→
T399 Pitane
 Plaster ceiling/wall lamp
 with one round blown glass
 GX53 - 1x10W
 Ø250 x d90 mm



↑←←
T400 Pitane
 Plaster ceiling/wall lamp
 with two round blown glass
 GX53 - 2x10W
 w410 x d90 x h300 mm





↑→
T401 Pitane
 Plaster ceiling/wall lamp
 with two round blown glass
 GX53 - 2x10W
 w390 x d330 x h90 mm



←↓
T402 Pitane
 Plaster ceiling/wall lamp with
 three round blown glass
 GX53 - 3x10W
 w410 x d410 x h90 mm





Demetra



T339 / T358 / T359
T360 / T361 / T362

_blank design studio

The frame of pure light. The Demetra plaster ceiling lamp, with one, two or three lights, is also available in dual-emission one-light or two-light wall-mounted versions. In all its variations, it features a round base, with rings containing the light point resting on it.

IT La cornice per una luce pura. La lampada a soffitto in gesso Demetra, a una, due o tre luci, è disponibile anche in versioni da parete ad una luce o biemissiva a due luci. In ogni sua declinazione presenta una base circolare su cui poggiano gli anelli che contengono il punto luce.

ES El marco para una luz pura. La lámpara de techo de yeso Demetra, con una, dos o tres luces, también está disponible en versiones de pared de una o dos luces. En cada una de sus variantes tiene una base circular sobre la que descansan los anillos que contienen el punto luminoso.

DE Der Rahmen für pures Licht. Die ein -, zwei - oder dreiflämmige Deckenleuchte aus Gips Demetra ist auch als ein - oder zweiflämmige Wandleuchte erhältlich. In jeder seiner Varianten hat er einen runden Sockel, auf dem die Ringe mit dem Lichtpunkt ruhen.

RU Обрамление для чистого света. Гипсовый потолочный светильник Demetra с одним, двумя или тремя источниками света предлагается и в настенных версиях с однонаправленным или двунаправленным свечением. Во всех версиях светильник имеет круглое основание с кольцами, внутри которых находится источник света.

Material / Materiale / Material / Material / Material / Материал

Plaster / Gesso / Gips / Yeso / штукатурка

Finish / Finitura / Fertigstellen / Terminar / закончить

White / Bianco / Weiß / Blanco / Белый

Light source / Fonte di luce / Lichtquelle / Fuente de luz / Источник света

GX53 x 10W

Type-approvals / Omologazioni / Zulassungen / Homologaciones / Разрешения





←↓
T339 Demetra
One-light plaster ceiling lamp
GX53 - 1x10W
Ø160 x h 60 mm





↑→
T358 Demetra
 Two-lights plaster ceiling lamp
 GX53 - 2x10W
 w290 x d180 x h55 mm



←↑
T359 Demetra
 Three-lights plaster ceiling lamp
 GX53 - 3x10W
 w280 x d255 x h58 mm





← ↑
T360 Demetra
One-light plaster wall lamp
GX53 - 1x10W
w165 x d130 x h65 mm



↑→
T361 Demetra
Two-lights plaster wall lamp
GX53 – 2x10W
w215 x d150 x h70 mm



←←↓
T362 Demetra
Two-lights double emission plaster wall lamp
GX53 – 2x10W
w190 x d150 x h105 mm



Sibari



T377 / T378
T379 / T380

_blank design studio

Essential and rational. Sibari - plaster ceiling lamp with one-, two- or three-lights - is also available in dual-emission one-light or two-light wall-mounted versions. It is characterised by rigorous lines and repeated geometric shapes, with variations in volume, size and thickness. In all its versions, it features an embossed square frame that houses the light point.

IT Essenziale e razionale. Sibari, lampada a soffitto in gesso con opzioni a una, due o tre luci è disponibile anche come lampada da parete ad una luce o doppia luce biemissiva e si caratterizza per linee rigorose e forme geometriche ripetute con variazioni di volumi, dimensioni e spessori. In tutte le declinazioni, una cornice quadrata in rilievo accoglie il punto luce.

ES Esencial y racional. Sibari, lámpara de techo de escayola con opciones de una, dos o tres luces, también está disponible como aplique de una o dos luces y se caracteriza por líneas rigurosas y formas geométricas repetidas con variaciones de volumen, tamaño y grosor. En todas las variantes, un marco cuadrado en relieve aloja el punto luminoso.

DE Wesentlich und rational. Sibari, eine ein-, zwei- oder dreiflämmige Deckenleuchte aus Gips, ist auch als ein- oder zweiflämmige Wandleuchte erhältlich und zeichnet sich durch strenge Linien und sich wiederholende geometrische Formen mit Variationen in Volumen, Größe und Dicke aus. Bei allen Deklinationen nimmt ein quadratischer Reliefrahmen den Lichtpunkt auf.

RU Сдержанность и рациональность. Гипсовый потолочный светильник Sibari, который может быть с одним, двумя или тремя источниками света, также доступен в настенной версии с однонаправленным или двунаправленным свечением. Изделие характеризуется строгими линиями и повторяющимися геометрическими формами с изменяющимися размерами, объемом и толщиной. Во всех версиях светильник комплектуется квадратной рельефной рамкой, охватывающей источник света.

Material / Materiale / Material / Material / Material / Material

Plaster / Gesso / Gips / Yeso / штукатурка

Finish / Finitura / Fertigstellen / Terminar / закончить

White / Bianco / Weiß / Blanco / Белый

Light source / Fonte di luce / Lichtquelle / Fuente de luz / Источник света

GX53 x 10W

Type-approvals / Omologazioni / Zulassungen / Homologaciones / Разрешения





↓ →
T377 Sibari
 Two-lights plaster ceiling lamp
 GX53 – 2x10W
 w290 x d207 x h53 mm



← ↑
T378 Sibari
 Three-lights plaster ceiling lamp
 GX53 – 3x10W
 w310 x d290 x h53 mm



↓ →
T379 Sibari
One-light plaster wall lamp
GX53 – 1x10W
w165 x d133 x h55 mm



← ← ↑
T380 Sibari
Two-lights double emission plaster wall lamp
GX53 – 2x10W
w206 x d153 x h95 mm



Anchise



T371 / T372 / T373
T374 / T375

_blank design studio

The Anchise plaster ceiling lamp with one, two or three lights available also in dual-emission one-light or two-light wall-mounted versions, is characterised by an irregular structure. Geometrical elements merge into broken surfaces, making it a protagonist when nestled between architectural profiles.

IT La lampada a soffitto in gesso Anchise a una, due o tre luci, disponibile da parete a una luce o biemissiva, si distingue per una struttura irregolare. Gli elementi geometrici si fondono in superfici spezzate che la rendono protagonista tra le linee dell'architettura.

ES La lámpara de techo de yeso Anchise de una, dos o tres luces, disponible como aplique de una luz o doble emisión, se caracteriza por una estructura irregular. Los elementos geométricos se funden en superficies quebradas que lo convierten en protagonista entre las líneas de la arquitectura.

DE Die ein-, zwei- oder dreiflämmige Deckenleuchte aus Gips Anchise, die auch als ein- oder zweiflämmige Wandleuchte erhältlich ist, zeichnet sich durch eine unregelmäßige Struktur aus. Geometrische Elemente gehen in gebrochene Flächen über, die ihn zu einem Protagonisten inmitten der Linien der Architektur machen.

RU Гипсовый потолочный светильник Anchise с одним, двумя или тремя источниками света, который предлагается и в настенной версии с однонаправленным или двунаправленным свечением, имеет основание неправильной формы. Геометрические элементы сливаются, образуя ломаные поверхности, благодаря чему светильник выигрышно выделяется среди линий интерьера.

Material / Materiale / Material / Material / Материал

Plaster / Gesso / Gips / Yeso / штукатурка

Finish / Finitura / Fertigstellen / Terminar / закончить

White / Bianco / Weiß / Blanco / Белый

Light source / Fonte di luce / Lichtquelle / Fuente de luz / Источник света

GX53 x 10W

Type-approvals / Omologazioni / Zulassungen / Homologaciones / Разрешения



↓ → →
T371 Anchise
 One light plaster ceiling lamp
 with irregular geometry
 GX53 – 1x10W
 w180 x d175 x h45 mm



← ↑
T372 Anchise
 Two light plaster ceiling lamp
 with irregular geometry
 GX53 – 2x10W
 w320 x d235 x h55 mm





↓↓→
T373 Anchise
Three light plaster ceiling lamp
with irregular geometry
GX53 - 3x10W
w338 x d320 x h45 mm





↓→
T374 Anchise
 One-light plaster wall lamp
 with irregular geometry
 GX53 – 1x10W
 w160 x d150 x h53 mm

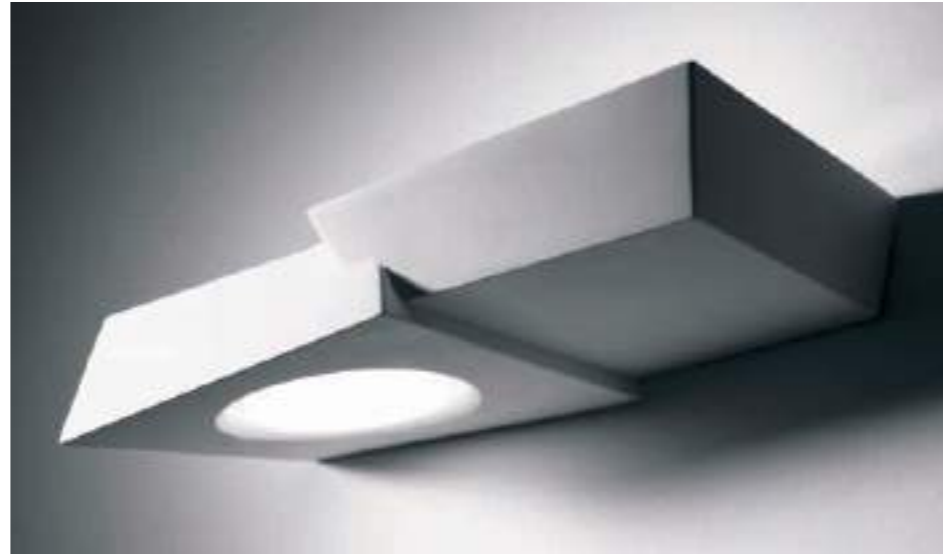

←↓
T375 Anchise
 Up/Down dual lighting plaster wall lamp
 with irregular geometry
 GX53 – 2x10W
 w274 x d150 x h64 mm



Chio



T262 / T263 / T264 / T274 / T278
T319 / T320 / T321 / T322

Acero design studio

Round architectures that welcome light. Chio - plaster ceiling or wall lamp - offers multiple combinations, with its many different versions from one to five lights, and dual-emission options. A fascinating interplay of solids and voids characterises the structure, in which cylindrical shapes of different thicknesses alternate with spaces housing the lighting point.

IT Architetture rotonde che accolgono la luce. Chio, lampada a soffitto o a parete in gesso, offre molteplici possibilità di combinazione grazie alle diverse versioni da una a cinque luci, con possibilità di varianti biemissive. Un affascinante gioco di pieni e vuoti caratterizza la struttura, in cui forme cilindriche di spessori differenti si alternano a spazi che ospitano il punto luce.

ES Arquitecturas redondas que acogen la luz. Chio, un plafón o aplique de yeso, ofrece múltiples posibilidades de combinación gracias a diferentes versiones de una a cinco luces, con posibilidad de variantes de doble emisión. Un fascinante juego de sólidos y vacíos caracteriza la estructura, en la que formas cilíndricas de distintos grosores se alternan con espacios que albergan el punto de luz.

DE Runde Architekturen, die das Licht willkommen heißen. Chio, eine Decken- oder Wandleuchte aus Gips, bietet vielfältige Kombinationsmöglichkeiten dank verschiedener Versionen von einer bis zu fünf Leuchten, mit der Möglichkeit von bi-emissiven Varianten. Ein faszinierendes Wechselspiel von Körpern und Hohlräumen kennzeichnet die Struktur, in der sich zylindrische Formen unterschiedlicher Dicke mit Räumen abwechseln, die den Lichtpunkt beherbergen.

RU Круглые формы, вобравшие в себя свет. Гипсовый потолочный или настенный светильник Chio обеспечивает возможность создания самых разнообразных комбинаций благодаря различным версиям, содержащим от одного до пяти источников света, включая варианты с двунаправленным свечением. В конструкции искусно обыгрывается сочетание геометрических тел и пустот: цилиндрические формы разной толщины чередуются с промежутками, в которых располагаются источники света.

Material / Materiale / Material / Material / Material / Material

Plaster / Gesso / Gips / Yeso / штукатурка

Finish / Finitura / Fertigstellen / Terminar / закончить

White / Bianco / Weiß / Blanco / Белый

Light source / Fonte di luce / Lichtquelle / Fuente de luz / Источник света

GX53 x 10W

Type-approvals / Omologazioni / Zulassungen / Homologaciones / Разрешения



| Wall, ceiling and pendant



T262 Chio

Three-lights plaster ceiling lamp
GX53 – 3x10W
w450 x d165 x h65 mm



T263 Chio

Three-lights plaster ceiling lamp
GX53 – 3x10W
w340 x d350 x h65 mm





↑↑→
T264 Chio
Five-lights plaster ceiling lamp
GX53 – 5x10W
w450 x d410 x h65 mm



↓ →
T274 Chio
 One-light plaster ceiling lamp
 GX53 - 1x10W
 w250 x d145 x h65 mm



← ↑
T278 Chio
 Two-lights plaster ceiling lamp
 GX53 - 2x10W
 w315 x d175 x h65 mm





↑ → →
T319 Chio
 One-light plaster wall lamp
 GX53 - 1x10W
 w200 x d125 x h85 mm



← ↓
T320 Chio
 Two-lights plaster wall lamp
 GX53 - 2x10W
 w335 x d150 x h105 mm



↓ →
T321 Chio
 Two-lights plaster wall lamp
 GX53 – 2x10W
 w340 x d150 x h105 mm



← ↑
T322 Chio
 Three-lights plaster wall lamp
 GX53 – 3x10W
 w415 x d150 x h110 mm



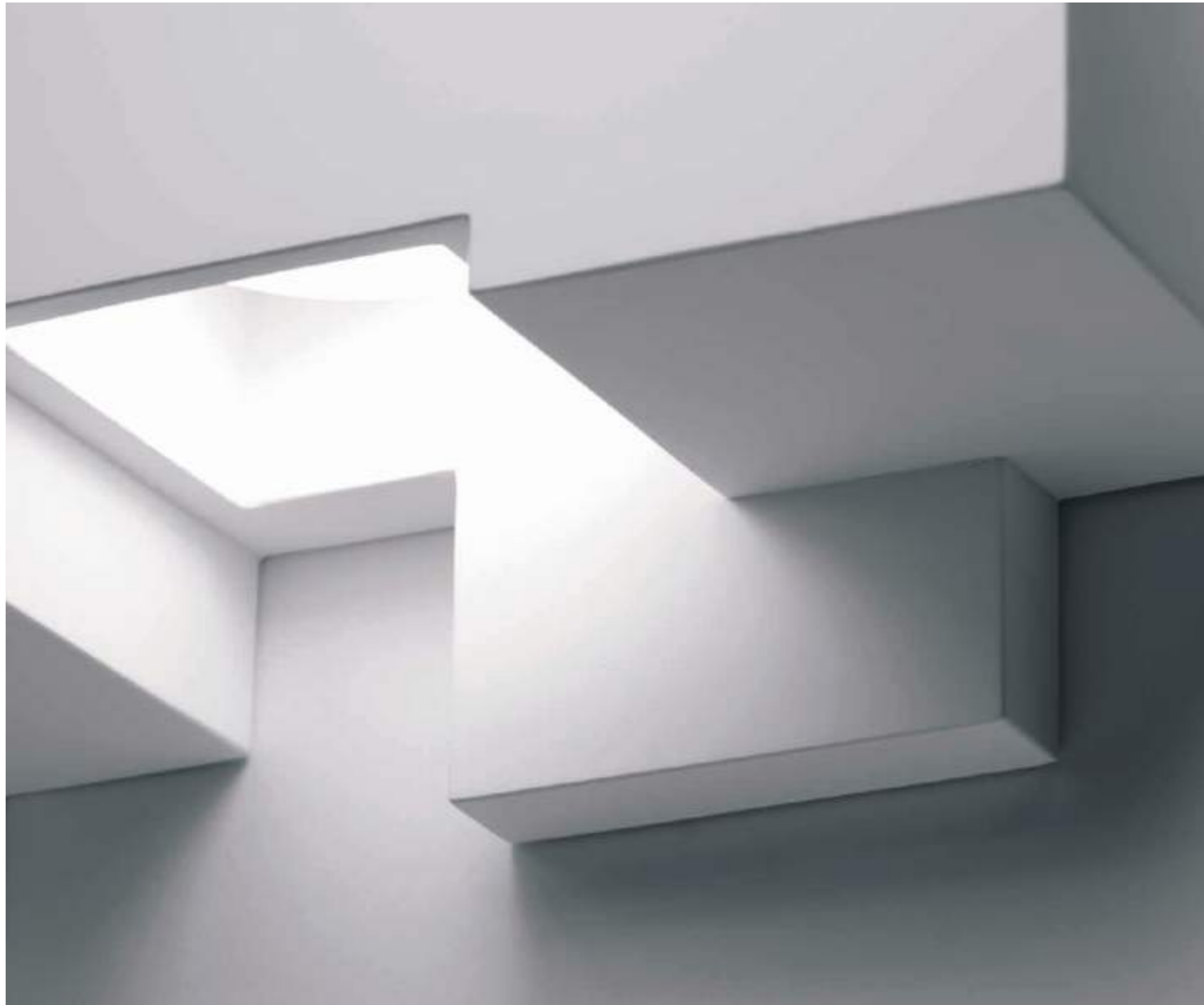

Side



T291 / T292 / T293
T326

Acero design studio

Essential and contemporary. The Side plaster lamp combines function and aesthetics in different combinations from one to three lights, with dual-emission variants in the wall-mounted version. In its geometric structure, regular shapes are interspersed with elements that frame illuminated spaces.

IT Essenziale e contemporanea. La lampada in gesso Side unisce funzionalità ed estetica in differenti combinazioni da una a tre luci, con varianti bi-emissive nella versione da parete. Nella sua struttura geometrica di forme regolari si intersecano elementi che incorniciano spazi illuminati.

ES Esencial y contemporánea. La lámpara de yeso Side combina funcionalidad y estética en distintas combinaciones de una a tres luces, con variantes de doble emisión en la versión de pared. En su estructura geométrica de formas regulares se entrecruzan elementos que enmarcan espacios iluminados.

DE Wesentlich und zeitgemäß. Die Gipsleuchte Side verbindet Funktionalität und Ästhetik in verschiedenen Kombinationen von ein bis drei Leuchten, mit bi-emissiven Varianten in der Wandversion. In ihrer geometrischen Struktur aus regelmäßigen Formen überschneiden sich Elemente, die beleuchtete Räume einrahmen.

RU Актуальность и современный дух. Гипсовый светильник Side, который предлагается в различных комбинациях с одним, двумя или тремя источниками света, а также в настенных версиях с двунаправленным свечением, сочетает в себе функциональность и эстетику. Конструкция, состоящая из геометрически правильных форм, создает игру пересекающихся элементов, которые обрамляют наполненные светом пространства.

Material / Materiale / Material / Material / Material / Материал

Plaster / Gesso / Gips / Yeso / Гипсовый

Finish / Finitura / Fertigstellen / Terminar / закончить

White / Bianco / Weiß / Blanco / Белый

Light source / Fonte di luce / Lichtquelle / Fuente de luz / Источник света

GX53 x 10W

Type-approvals / Omologazioni / Zulassungen / Homologaciones / Разрешения



↓ →
T291 Side
 One-light plaster ceiling lamp
 GX53 – 1x10W
 w335 x d250 x h70 mm



← ↑
T292 Side
 Two-lights plaster ceiling lamp
 GX53 – 2x10W
 w420 x d395 x h70 mm



↓→
T293 Side
Three-lights plaster ceiling lamp
GX53 - 3x10W
w420 x d420 x h75 mm



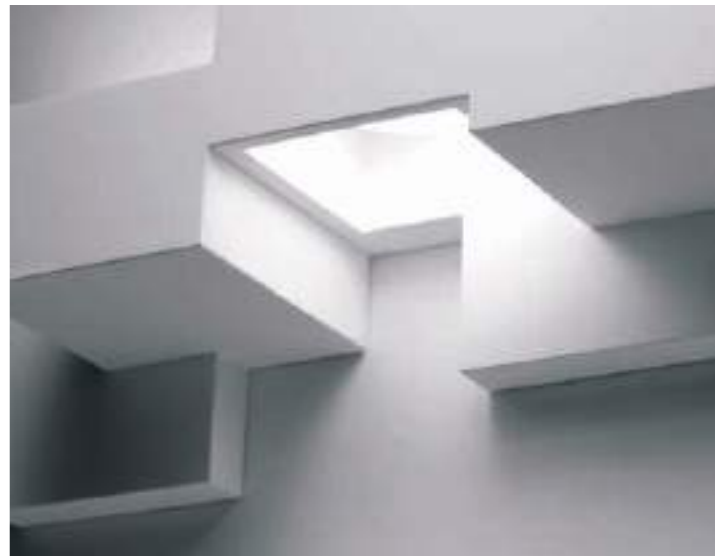

← ↑ ↑
T326 Side
Three-lights Up/down plaster wall lamp
GX53 – 3x10W
w440 x d120 x h230 mm

Side Small



T367 / T368 / T369

Acero design studio

Compact and pure. In the Small version, the Side lamp is characterised by the same formal purity, although in an essential configuration. Available in single-light ceiling-mounted and single and dual-emission wall-mounted versions. Its small dimensions make it a rational detail on the surfaces on which it is installed.

IT Compatta e pura. Nella versione Small, la lampada Side è caratterizzata dalla stessa purezza formale in una configurazione essenziale. Disponibile nelle versioni a soffitto ad una luce e a parete mono e biemissiva. Le sue dimensioni ridotte la rendono un dettaglio razionale delle superfici su cui viene installata.

DE Kompakt und rein. In der Version Small zeichnet sich die Leuchte Side durch die gleiche formale Reinheit in einer essentiellen Konfiguration aus. Erhältlich als einflam-mige Deckenleuchte sowie als ein- und zweiflammige Wandleuchte. Ihre geringen Abmessungen machen sie zu einem rationellen Detail auf den Oberflächen, auf denen sie installiert wird.

ES Compatta y pura. En la versión Small, la lámpara Side se caracteriza por la misma pureza formal en una configuración esencial. Disponible en versiones de techo de una luz y de pared de una o dos luces. Sus reducidas dimensiones lo convierten en un detalle racional de las superficies en las que se instala.

RU Компактность и лаконичность. Светильник Side в версии Small характеризуется чистотой форм, характерной и для его основной конфигурации. Предлагаются потолочные версии с одним источником света, а также настенные версии с однонаправленным и двунаправленным свечением. Компактность этого светильника позволяет рациональным образом использовать поверхности, на которые он устанавливается.

Material / Materiale / Material / Material / Материал

Plaster / Gesso / Gips / Yeso / Гипсовый

Finish / Finitura / Fertigstellen / Terminar / закончить

White / Bianco / Weiß / Blanco / Белый

Light source / Fonte di luce / Lichtquelle / Fuente de luz / Источник света

GX53 x 10W

Type-approvals / Omologazioni / Zulassungen / Homologaciones / Разрешения



I Wall, ceiling and pendant



↓→
T367 Side Small
 Two-lights plaster wall lamp
 GX53 – 2x10W
 w275 x d120 x h130 mm

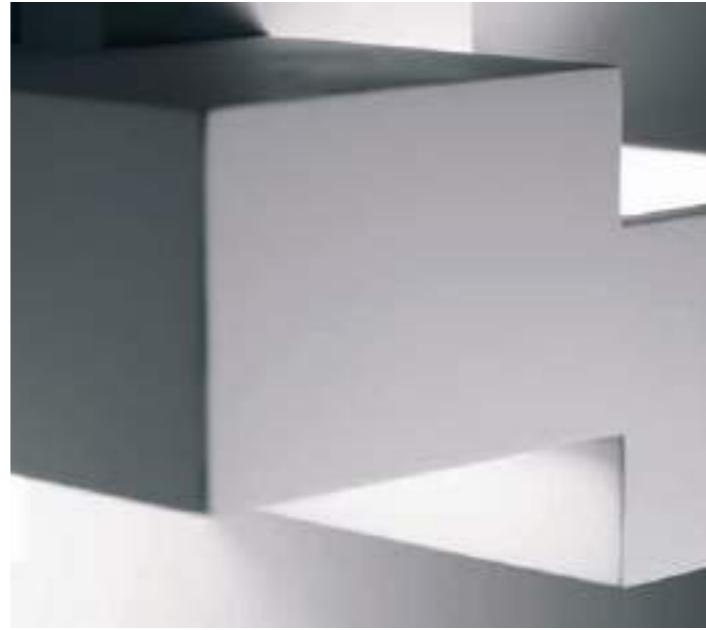

←↓
T368 Side Small
 Up/Down dual lighting plaster wall lamp
 GX53 – 2x10W
 w275 x d120 x h130 mm





↓↓→
T369 Side Small
One-light plaster ceiling lamp
GX53 – 1x10W
w220 x d195 x h70 mm



Heraea



T193 / T194
T205

Acero design studio

Simple and dynamic. The Heraea collection consists of plaster ceiling lamps with three or five lights, and a dual-emission three-light wall-mounted version. The elements, combined with each other and positioned at different heights, give verticality and dynamism to the structure.

IT Semplice e dinamica. La collezione Heraea è composta da lampade a soffitto in gesso a tre o cinque luci e presenta anche una versione da parete a tre luci con doppia emissione. Gli elementi, combinati tra loro e posizionati ad altezze diverse, conferiscono verticalità e dinamismo alla struttura.

ES Sencilla y dinámica. La colección Heraea consta de lámparas de techo de yeso con tres o cinco luces y también cuenta con una versión de pared de tres luces con doble emisión. Los elementos, combinados entre sí y colocados a distintas alturas, aportan verticalidad y dinamismo a la estructura.

DE Einfach und dynamisch. Die Kollektion Herea besteht aus Deckenleuchten aus Gips mit drei oder fünf Leuchten sowie aus einer dreiflammi- gen Wandleuchte mit dop- peltem Lichtaustritt. Die mit- einander kombinierten und in unterschiedlichen Höhen angeordneten Elemente ver- leihen der Struktur Vertikalität und Dynamik.

RU Простота и динамичность. Коллекция Heraea включает в себя гипсовые потолочные светильники с тремя или пятью источниками света, а также настенную версию с дву- направленным свечением и с тремя источниками света. Скомбинированные друг с другом элементы, расположен- ные на разной высоте, придают конструкции вертикальность и динамичность.

Material / Materiale / Material /
Material / Материал

Plaster / Gesso / Gips / Yeso /
Гипсовый

Finish / Finitura / Fertigstellen /
Terminar / закончить

White / Bianco / Weiß / Blanco /
Белый

Light source / Fonte di luce /
Lichtquelle / Fuente de luz /
Источник света

GU10 x 40W
G9 x 40W

Type-approvals / Omologazioni /
Zulassungen / Homologaciones /
Разрешения





T193 Heraea

Three-lights plaster ceiling lamp
 GU10 – 3x40W
 w240 x d190 x h150 mm



T194 Heraea

Five-lights plaster ceiling lamp
 GU10 – 5x40W
 w240 x d330 x h150 mm



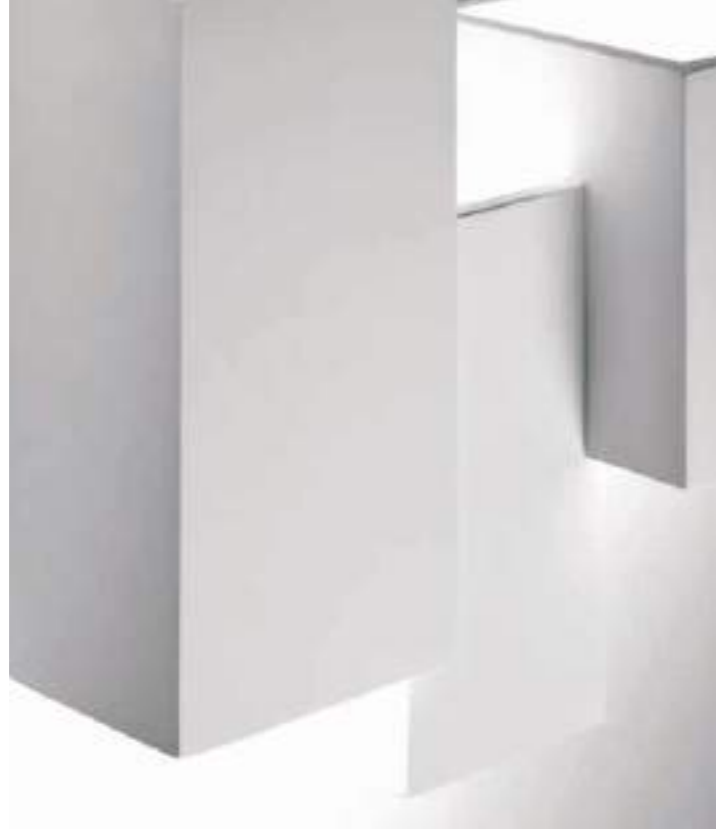

↓↓→
T205 Heraea
Up/down lights plaster wall lamp
G9 – 4x40W
w285 x d120 x h240 mm



Paro

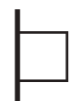

T269 / T270

Acero design studio

Contemporary design. Paro - a dual-emission two- or three-volume plaster wall lamp - is defined by rectangular, recessed elements that generate diffuse light, perfect to illuminate even larger rooms.

IT Design contemporaneo.

Paro, lampada da parete in gesso a due o tre volumi con doppia emissione, si definisce attraverso elementi rettangolari, incassati tra loro che generano una luce diffusa, capace di illuminare anche ambienti ampi.

ES Diseño contemporáneo.

Paro, aplique de yeso de dos o tres volúmenes con doble emisión, se define por unos elementos rectangulares y empotrados que generan una luz difusa, capaz de iluminar incluso grandes estancias.

DE Zeitgemäßes Design.

Paro, eine zwei - oder dreiflächige Wandleuchte aus Gips mit doppeltem Lichtaustritt, zeichnet sich durch rechteckige, eingelassene Elemente aus, die ein diffuses Licht erzeugen, das auch große Räume beleuchten kann.

RU Современный дизайн.

Paro, гипсовый настенный светильник с двунаправленным свечением, состоящий из двух или трех блоков, характеризуется прямоугольными элементами, встроенными друг в друга и подающими рассеянный свет, способный осветить даже большие помещения.

Material / Materiale / Material / Material / Material / Материал

Plaster and glass / Gesso e vetro / Cips und Glas / Yeso y vidrio / Гипс и стекло

Finish / Finitura / Fertigstellen / Terminar / закончить

White / Bianco / Weiß / Blanco / Белый

Light source / Fonte di luce / Lichtquelle / Fuente de luz / Источник света

C9 x 40W

Type-approvals / Omologazioni / Zulassungen / Homologaciones / Разрешения



↓ →
T269 Paro
 Three-lights,
 double emission plaster wall lamp
 G9 – 3x40W
 w450 x d106 x h180 mm

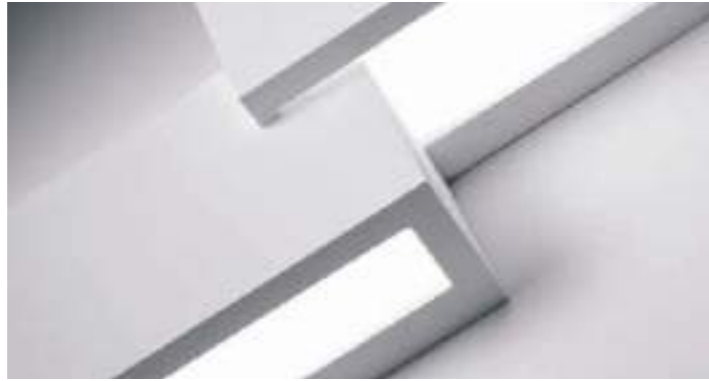

← ↑
T270 Paro
 Five-lights,
 double emission plaster wall lamp
 G9 – 5x40W
 w610 x d120 x h180 mm





Delfi



T223

Luca Artioli

A surface in sinuous movement. Delfi - dual-emission two-light plaster wall-mounted lamp for direct or indirect lighting - conceals the light points within a curved structure that gives a motion effect, breaking up the rigour of architectural surfaces. The structure framing the emission area can be painted, so that it becomes integral or contrasting with the wall on which it is installed.

IT Una superficie in sinuoso movimento. La lampada a parete in gesso Delfi a due luci a doppia emissione per illuminazione diretta o indiretta, cela i punti luce all'interno di una struttura curva che conferisce un effetto di movimento, rompendo la staticità delle superfici architettoniche. La struttura che incornicia l'area di emissione può essere verniciata per diventare parte integrante o a contrasto della parete su cui viene installata.

ES Una superficie en movimiento sinuoso. El aplique de yeso de dos luces Delfi para iluminación directa o indirecta oculta los puntos de luz dentro de una estructura curva que da un efecto de movimiento, rompiendo el rigor de las superficies arquitectónicas. La estructura que enmarca la zona de emisión puede pintarse para convertirse en parte integrante o contrastada de la pared en la que se instala.

DE Eine Oberfläche in gewundener Bewegung. Die zweiflämmige Gipswandleuchte Delfi für direkte oder indirekte Beleuchtung verbirgt die Lichtpunkte in einer geschwungenen Struktur, die einen Bewegungseffekt erzeugt und die Strenge der architektonischen Oberflächen auf bricht. Die Struktur, die den Emissionsbereich einrahmt, kann so gestrichen werden, dass sie einen integralen oder kontrastierenden Teil der Wand bildet, an der sie installiert ist.

RU Поверхность с плавным изгибом. Гипсовый настенный светильник Delfi с двумя источниками света и с двуправленным свечением предназначен для прямого или непрямого освещения. Источники света находятся внутри изогнутого корпуса, который создает эффект движения, оживляя строгие поверхности стен. Корпус, обрамляющий зону излучения светового потока, можно окрасить, благодаря чему он станет гармоничной частью либо контрастным элементом стены, на которой установлен светильник.

Material / Materiale / Material / Material / Материал

Plaster and glass / Gesso e vetro / Gips und Glas / Yeso y vidrio / Гипс и стекло

Finish / Finitura / Fertigstellen / Terminar / закончить

White / Bianco / Weiß / Blanco / Белый

Light source / Fonte di luce / Lichtquelle / Fuente de luz / Источник света

G9 x 40W

Type-approvals / Omologazioni / Zulassungen / Homologaciones / Разрешения





←
T223 Delfi
Two-lights plaster wall lamp
G9 – 2x40W
w350 x d100x h125 mm

Teos



T174.10 / T174.11 / T174.12

Acero design studio

Expression of light. Teos - dual-emission plaster wall lamp - features a sloping structure that shapes the light beam, initially wide and then delicately thin, giving it a distinctive effect. Available in different lengths, it can be painted to match the environment to blend in with the surface or contrast it to elegantly reveal its shape.

IT Espressione di luce. Teos, lampada da parete in gesso con doppia emissione, presenta una struttura inclinata che modella il fascio luminoso, inizialmente ampio e poi delicatamente sottile, che regala un effetto distintivo. Disponibile in diverse lunghezze, può essere verniciata in accordo all'ambiente per integrarsi alla superficie o a contrasto per rivelare elegantemente le sue forme.

ES Expresión de luz. Teos, un aplique de yeso con doble emisión, presenta una estructura inclinada que modela el haz de luz, inicialmente ancho y luego delicadamente fino, dándole un efecto distintivo. Disponible en diferentes longitudes, puede pintarse a juego con el entorno para mimetizarse con la superficie o contrastarse para revelar con elegancia su forma.

DE Ausdruck von Licht. Teos, eine Wandleuchte aus Gips mit doppeltem Lichtaustritt, zeichnet sich durch eine schräge Struktur aus, die das Lichtbündel zunächst breit und dann zart auslaufen lässt und ihm eine besondere Wirkung verleiht. Sie ist in verschiedenen Längen erhältlich und kann je nach Umgebung gestrichen werden, um mit der Oberfläche zu verschmelzen, oder kontrastiert werden, um ihre Form elegant zur Geltung zu bringen.

RU Олицетворение света. Гипсовый настенный светильник Teos с двунаправленным свечением имеет наклонный корпус, формирующий световой пучок, который изначально является широким, а затем мягко утончается, создавая неповторимый эффект. Светильник выпускается в разных вариантах длины и может окрашиваться в цвета интерьера, чтобы гармонично слиться с поверхностью, либо в контрастные цвета, чтобы элегантно подчеркнуть объемы.

Material / Materiale / Material / Material / Material / Material

Plaster and glass / Gesso e vetro / Gips und Glas / Yeso y vidrio / Гипс и стекло

Finish / Finitura / Fertigstellen / Terminar / закончить

White / Bianco / Weiß / Blanco / Белый

Light source / Fonte di luce / Lichtquelle / Fuente de luz / Источник света

G9 x 40W

Type-approvals / Omologazioni / Zulassungen / Homologaciones / Разрешения



Example of painted product
Esempio di prodotto verniciato
Beispiel für das gestrichene Produkt
Ejemplo de producto pintado
Пример окрашенного прибора

↓ →
T174.10 Teos
 Plaster wall light, dual emission
 G9 – 2x40W
 w230 x d105 x h78 mm

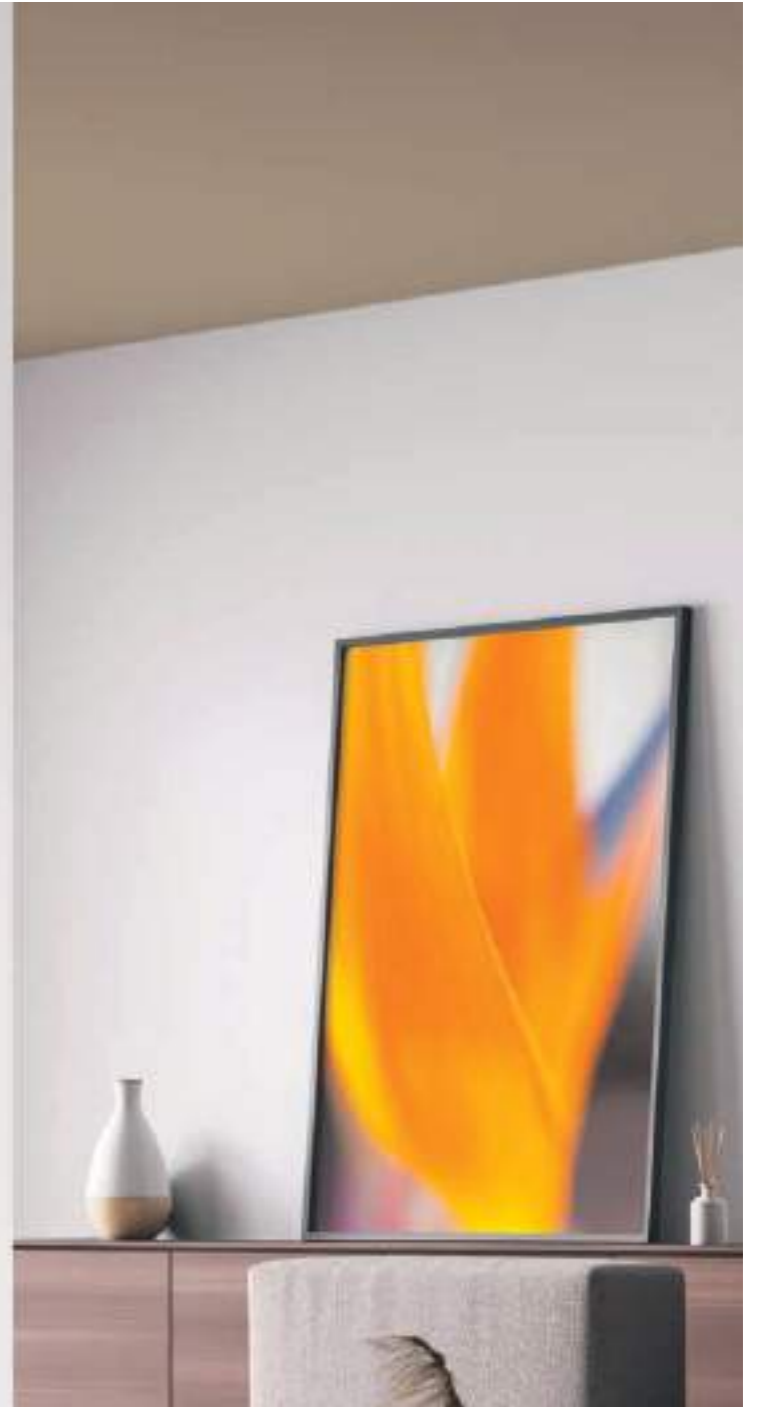

← ↑
T174.11 Teos
 Plaster wall light, dual emission
 G9 – 2x40W
 w340 x d105 x h78 mm





↙↘
T174.12 Teos
Plaster wall light, dual emission
G9 – 3x40W
w470 x d105 x h78 mm



Pellene



T200 / T201

Luca Artioi

Formality and dynamism. The Pellene plaster wall lamp, with one or two lights, creates a distinctive light emission thanks to its flared structure: thin at the bottom and wide at the top. The sinuous front wave, emphasised by the light streaming from it, lends movement and an elegant decorative effect.

IT Formalità e dinamismo. La lampada a parete in gesso Pellene, ad una o due luci, grazie alla struttura svasata crea una distintiva emissione luminosa: sottile nella parte inferiore e ampia nella parte superiore. La sinuosa onda frontale, sottolineata dalla luce che ne fuoriesce radente, conferisce movimento ed un elegante effetto decorativo.

ES Formalidad y dinamismo. El aplique de yeso Pellene, de uno o dos luces, crea una emisión luminosa distintiva gracias a su estructura acampanada: estrecha en la parte inferior y ancha en la superior. La onda sinuosa de la parte frontal, acentuada por la luz que sale de la misma, aporta movimiento y un elegante efecto decorativo.

DE Formalität und Dynamik. Die ein- oder zweiflämmige Wandleuchte Pellene aus Gips erzeugt dank ihrer aufgeweiteten Struktur, die unten dünn und oben breit ist, einen unverwechselbaren Lichtschein. Die geschwungene Welle auf der Vorderseite, die durch das von ihr ausgehende Licht hervorgehoben wird, sorgt für Bewegung und einen eleganten dekorativen Effekt.

RU Строгость и динамичность. Гипсовый настенный светильник Pellene с одним или двумя источниками света обеспечивает оригинальное освещение благодаря особой форме корпуса, более узкого в нижней части и расширяющегося вверху. Изящная волна на передней стороне, чей контур подчеркивается струящимся из нее светом, создает эффект движения и превращается в элегантный декоративный элемент.

Material / Materiale / Material / Material / Material / Материал

Plaster / Gesso / Gips / Yeso / Гипсовый

Finish / Finitura / Fertigstellen / Terminar / закончить

White / Bianco / Weiß / Blanco / Белый

Light source / Fonte di luce / Lichtquelle / Fuente de luz / Источник света

G9 x 40W

Type-approvals / Omologazioni / Zulassungen / Homologaciones / Разрешения





↓ →
T200 Pellene
One-light dual emission plaster
wall lamp with frontal beamline
G9 – 1x40W
w220 x d75 x h75 mm



← ↑
T201 Pellene
Two-lights dual emission plaster
wall lamp with frontal beamline
G9 – 2x40W
w355 x d85 x h75 mm





Hermione



T208 / T209 / T210

Acero design studio

Luminous essence. Hermione, dual-emission plaster wall lamp, conceals the light point within a structure that allows the light beam to flow upwards and downwards. Available in three sizes, it can be painted to blend in with the environment or create a bold contrast.

IT Essenza luminosa. Hermione, lampada a parete in gesso a doppia emissione, cela il punto luce all'interno di una struttura che permette al fascio luminoso di fluire verso l'alto e il basso. Proposta in tre dimensioni, può essere verniciata in modo da integrarsi con l'ambiente o creare un audace contrasto.

ES Esencia luminosa. Hermione, un aplique de yeso de doble emisión, oculta el punto de luz dentro de una estructura que permite que el haz luminoso fluya hacia arriba y hacia abajo. Disponible en tres tamaños, puede pintarse para mimetizarse con el entorno o crear un atrevido contraste.

DE Leuchtende Essenz. Hermione, eine Wandleuchte aus Gips mit doppeltem Lichtaustritt, verbirgt den Lichtpunkt in einer Struktur, die den Lichtstrahl nach oben und nach unten fließen lässt. Sie ist in drei Größen erhältlich und kann so lackiert werden, dass sie sich in die Umgebung einfügt oder einen starken Kontrast bildet.

RU Квинтэссенция света. У гипсового настенного светильника Hermione с двунаправленным свечением источник света скрыт внутри корпуса, откуда световой пучок струится в направлении вверх и вниз. Светильник представлен в трех вариантах размеров и может окрашиваться для гармоничного слияния с интерьером либо создания яркого контраста.

Material / Materiale / Material / Material / Материал

Plaster and glass / Gesso e vetro / Gips und Glas / Yeso y vidrio / Гипс и стекло

Finish / Finitura / Fertigstellen / Terminar / закончить

White / Bianco / Weiß / Blanco / Белый

Light source / Fonte di luce / Lichtquelle / Fuente de luz / Источник света

G9 x 40W

Type-approvals / Omologazioni / Zulassungen / Homologaciones / Разрешения





T208 Hermione
Plaster, dual emission wall light
G9 – 1x40W
w220 x d75 x h70 mm



T209 Hermione
Plaster, dual emission wall light
G9 – 2x40W
w350 x d70 x h70 mm

→
T210 Hermione

Plaster, dual emission wall light
G9 – 3x40W
w525 x d80 x h75 mm



Technical appendix

Appendice tecnica
Technischer Anhang
Apéndice técnico
Техническое приложение

Extruded profiles

Profili estrusi
Extrudiert Profile
Extruido perfiles
Экструдированный профили

T133 Emathia - p. 40
Aluminium - White

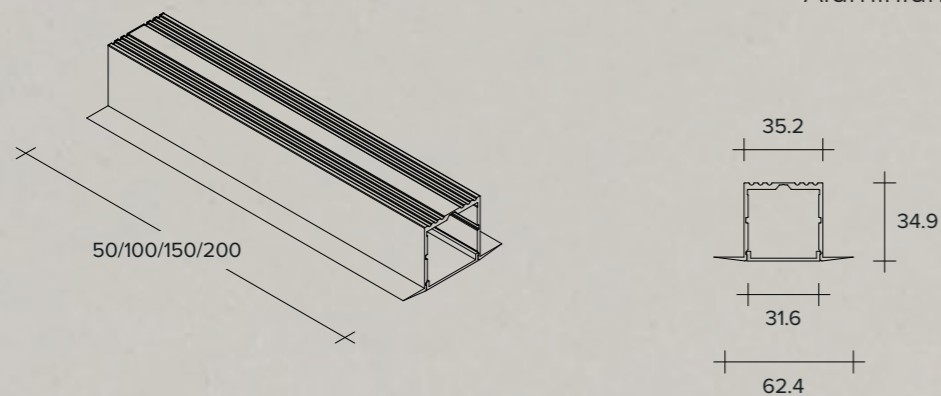

The system is made of aluminium or white coated extruded aluminium with an Opal or Satin cover

Designed by	Tecnico R&D
Mounting / Montaggio / Montage / Montaje / сборка	Recessed (T133)
Material / Materiale / Material / Material / Материал	Aluminum / Alluminio / Aluminium / Alumínio /Алюминий
Light source / Fonte di luce / Lichtquelle / Fuente de luz / Источник света	LED strip - p. 354

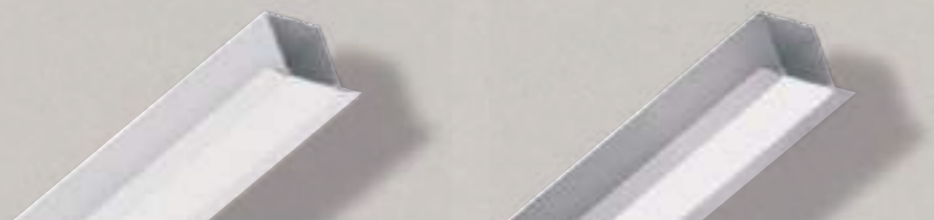

Model	cm	Cover	Finish	Model	cm	Cover	Finish
T133.W.50.OPAL	50	Opal	White	T133.AL.50.OPAL	50	Opal	Alum.
T133.W.50.SAT	50	Sat	White	T133.AL.50.SAT	50	Sat	Alum.
T133.W.100.OPAL	100	Opal	White	T133.AL.100.OPAL	100	Opal	Alum.
T133.W.100.SAT	100	Sat	White	T133.AL.100.SAT	100	Sat	Alum.
T133.W.150.OPAL	150	Opal	White	T133.AL.150.OPAL	150	Opal	Alum.
T133.W.150.SAT	150	Sat	White	T133.AL.150.SAT	150	Sat	Alum.
T133.W.200.OPAL	200	Opal	White	T133.AL.200.OPAL	200	Opal	Alum.
T133.W.200.SAT	200	Sat	White	T133.AL.200.SAT	200	Sat	Alum.

T133.w / T133.al TAGLIO

Profile cut-to-size service, according to the drawing provided / Servizio di taglio del profilo secondo disegno fornito / Profilzuschnitt nach gelieferter Zeichnung / Servicio de corte del perfil según el diseño proporcionado / Услуги резки профиля на основании предоставленного чертежа

T139 / T145 Eubea - p. 44
Aluminium - White

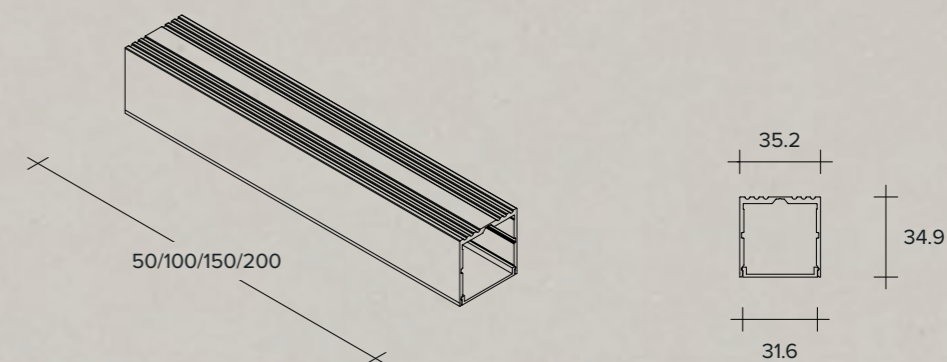

The system is made of aluminium or white coated extruded aluminium with an Opal or Satin cover

Designed by	Tecnico R&D
Mounting / Montaggio / Montage / Montaje / сборка	Recessed (T139) Surface (T145)
Material / Materiale / Material / Material / Материал	Aluminum / Alluminio / Aluminium / Alumínio /Алюминий
Light source / Fonte di luce / Lichtquelle / Fuente de luz / Источник света	LED strip - p. 354



Model	cm	Cover	Finish	Model	cm	Cover	Finish
T139.W.50.OPAL	50	Opal	White	T139.AL.50.OPAL	50	Opal	Alum.
T139.W.50.SAT	50	Sat	White	T139.AL.50.SAT	50	Sat	Alum.
T139.W.100.OPAL	100	Opal	White	T139.AL.100.OPAL	100	Opal	Alum.
T139.W.100.SAT	100	Sat	White	T139.AL.100.SAT	100	Sat	Alum.
T139.W.150.OPAL	150	Opal	White	T139.AL.150.OPAL	150	Opal	Alum.
T139.W.150.SAT	150	Sat	White	T139.AL.150.SAT	150	Sat	Alum.
T139.W.200.OPAL	200	Opal	White	T139.AL.200.OPAL	200	Opal	Alum.
T139.W.200.SAT	200	Sat	White	T139.AL.200.SAT	200	Sat	Alum.

T133.w / T133.al TAGLIO

Profile cut-to-size service, according to the drawing provided / Servizio di taglio del profilo secondo disegno fornito / Profilzuschnitt nach gelieferter Zeichnung / Servicio de corte del perfil según el diseño proporcionado / Услуги резки профиля на основании предоставленного чертежа

T221 Oropus - p. 50

Aluminium - White

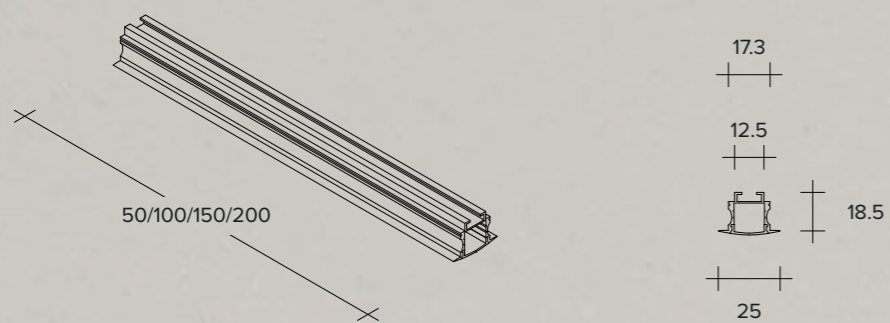

The system is made of aluminium or white coated extruded aluminium with an Opal or Satin cover

Designed by	Tecnico R&D
Mounting / Montaggio / Montage / Montaje / сборка	Recessed (T221)
Material / Materiale / Material / Material / Материал	Aluminum / Alluminio / Aluminium / Aluminio /Алюминий
Light source / Fonte di luce / Lichtquelle / Fuente de luz / Источник света	LED strip - p. 354



Model	cm	Cover	Finish	Model	cm	Cover	Finish
T221.W.50.OPAL	50	Opal	White	T221.AL.50.OPAL	50	Opal	Alum.
T221.W.50.SAT	50	Sat	White	T221.AL.50.SAT	50	Sat	Alum.
T221.W.100.OPAL	100	Opal	White	T221.AL.100.OPAL	100	Opal	Alum.
T221.W.100.SAT	100	Sat	White	T221.AL.100.SAT	100	Sat	Alum.
T221.W.150.OPAL	150	Opal	White	T221.AL.150.OPAL	150	Opal	Alum.
T221.W.150.SAT	150	Sat	White	T221.AL.150.SAT	150	Sat	Alum.
T221.W.200.OPAL	200	Opal	White	T221.AL.200.OPAL	200	Opal	Alum.
T221.W.200.SAT	200	Sat	White	T221.AL.200.SAT	200	Sat	Alum.

T133.w / T133.al TAGLIO

Profile cut-to-size service, according to the drawing provided / Servizio di taglio del profilo secondo disegno fornito / Profilzuschnitt nach gelieferter Zeichnung / Servicio de corte del perfil según el diseño proporcionado / Услуги резки профиля на основании предоставленного чертежа

T220 Chalcis - p. 52

Aluminium - White

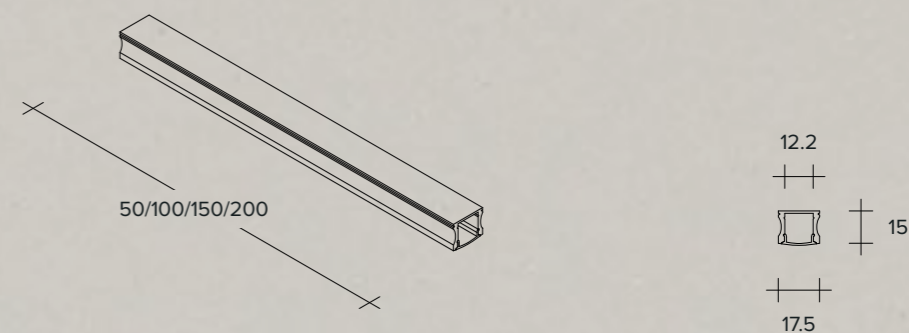

The system is made of aluminium or white coated extruded aluminium with an Opal or Satin cover

Designed by	Tecnico R&D
Mounting / Montaggio / Montage / Montaje / сборка	Surface (T220)
Material / Materiale / Material / Material / Материал	Aluminum / Alluminio / Aluminium / Aluminio /Алюминий
Light source / Fonte di luce / Lichtquelle / Fuente de luz / Источник света	LED strip - p. 354



Model	cm	Cover	Finish	Model	cm	Cover	Finish
T220.W.50.OPAL	50	Opal	White	T220.AL.50.OPAL	50	Opal	Alum.
T220.W.50.SAT	50	Sat	White	T220.AL.50.SAT	50	Sat	Alum.
T220.W.100.OPAL	100	Opal	White	T220.AL.100.OPAL	100	Opal	Alum.
T220.W.100.SAT	100	Sat	White	T220.AL.100.SAT	100	Sat	Alum.
T220.W.150.OPAL	150	Opal	White	T220.AL.150.OPAL	150	Opal	Alum.
T220.W.150.SAT	150	Sat	White	T220.AL.150.SAT	150	Sat	Alum.
T220.W.200.OPAL	200	Opal	White	T220.AL.200.OPAL	200	Opal	Alum.
T220.W.200.SAT	200	Sat	White	T220.AL.200.SAT	200	Sat	Alum.

T133.w / T133.al TAGLIO

Profile cut-to-size service, according to the drawing provided / Servizio di taglio del profilo secondo disegno fornito / Profilzuschnitt nach gelieferter Zeichnung / Servicio de corte del perfil según el diseño proporcionado / Услуги резки профиля на основании предоставленного чертежа

T309 Methoni - p. 58

White

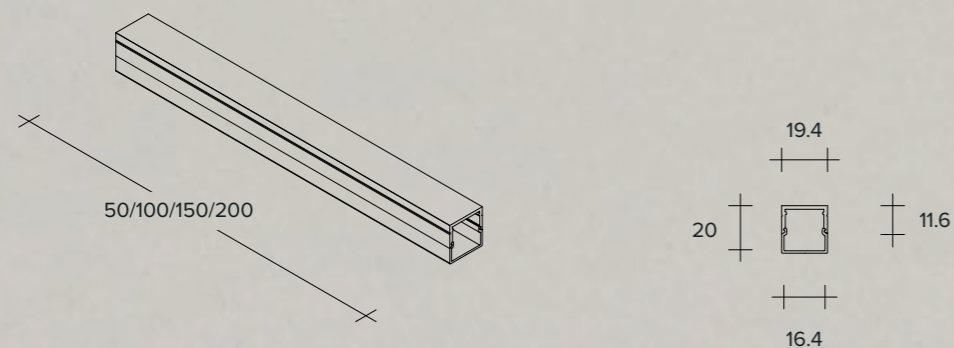

The system is made of aluminium coated extruded aluminium with an Opal or Satin cover

Designed by	Tecnico R&D
Mounting / Montaggio / Montage / Montaje / сборка	Surface (T309)
Material / Materiale / Material / Material / Материал	Aluminum / Alluminio / Aluminium / Aluminio /Алюминий
Light source / Fonte di luce / Lichtquelle / Fuente de luz / Источник света	LED strip - p. 354

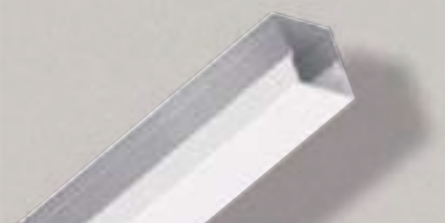

Model	cm	Cover	Finish
T309.AL.50.OPAL	50	Opal	White
T309.AL.100.OPAL	100	Opal	White
T309.AL.150.OPAL	150	Opal	White
T309.AL.200.OPAL	200	Opal	White

T133.w / T133.al TAGLIO

Profile cut-to-size service, according to the drawing provided / Servizio di taglio del profilo secondo disegno fornito / Profilzuschnitt nach gelieferter Zeichnung / Servicio de corte del perfil según el diseño proporcionado / Услуги резки профиля на основании предоставленного чертежа

T310 Icus - p. 62

White

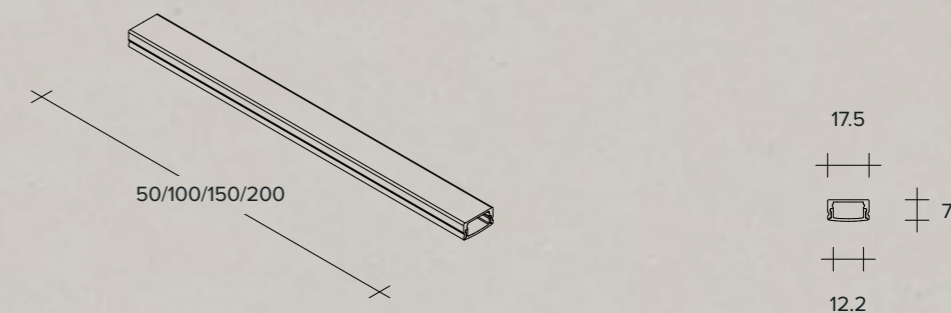

The system is made of aluminium coated extruded aluminium with an Opal or Satin cover

Designed by	Tecnico R&D
Mounting / Montaggio / Montage / Montaje / сборка	Surface (T310)
Material / Materiale / Material / Material / Материал	Aluminum / Alluminio / Aluminium / Aluminio /Алюминий
Light source / Fonte di luce / Lichtquelle / Fuente de luz / Источник света	LED strip - p. 354

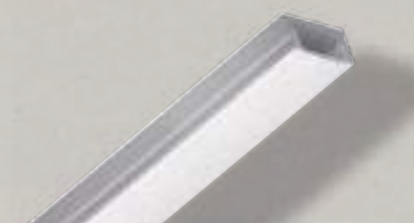

Model	cm	Cover	Finish
T310.AL.50.OPAL	50	Opal	Alum.
T310.AL.100.OPAL	100	Opal	Alum.
T310.AL.150.OPAL	150	Opal	Alum.
T310.AL.200.OPAL	200	Opal	Alum.

T133.w / T133.al TAGLIO

Profile cut-to-size service, according to the drawing provided / Servizio di taglio del profilo secondo disegno fornito / Profilzuschnitt nach gelieferter Zeichnung / Servicio de corte del perfil según el diseño proporcionado / Услуги резки профиля на основании предоставленного чертежа

LED

LED source / LED-Lichtquelle / Fuente de LED / Светодиодный источник света

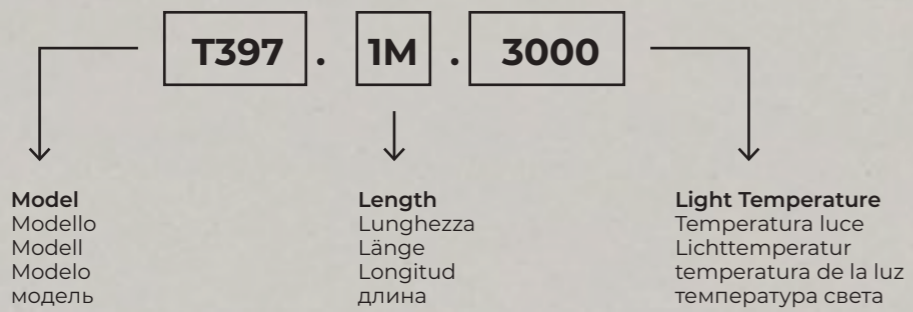
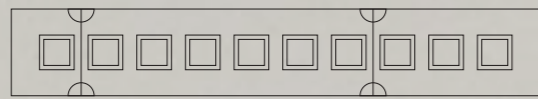

T397.__M.3000	T397.__M.4000	T398.__M.3000	T398.__M.4000
3000 K°	4000 K°	3000 K°	4000 K°
14,4 W/m	14,4 W/m	19,2 W/m	19,2 W/m
Ra80	Ra80	Ra90	Ra90
2016 lumen/m	2232 lumen/m	2400 lumen/m	2640 lumen/m
160 led/m	160 led/m	240 led/m	240 led/m
24 V	24 V	24 V	24 V

Strip Led 3000°K

Model	Length	Model	Length
T397.1M.3000	100 cm	T398.1M.3000	100 cm
T397.2M.3000	200 cm	T398.2M.3000	200 cm
T397.3M.3000	300 cm	T398.3M.3000	300 cm
T397.4M.3000	400 cm	T398.4M.3000	400 cm
T397.5M.3000	500 cm	T398.5M.3000	500 cm

Strip Led 4000°K

Model	Length	Model	Length
T397.1M.4000	100 cm	T398.1M.4000	100 cm
T397.2M.4000	200 cm	T398.2M.4000	200 cm
T397.3M.4000	300 cm	T398.3M.4000	300 cm
T397.4M.4000	400 cm	T398.4M.4000	400 cm
T397.5M.4000	500 cm	T398.5M.4000	500 cm

Power supply

Alimentatori / Netzgeräte / Fuentes de alimentación / Блоки питания

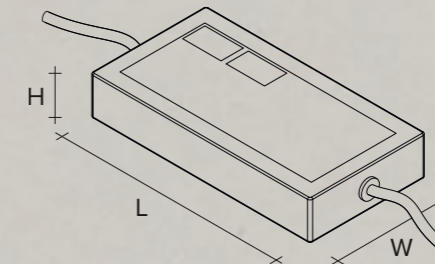

	L x H x W		L x H x W
T73.40W.24.DIM	171x30x40mm	T73.50W.24.SNP	160x58x18mm
T73.100W.24.DIM	220x30x40mm	T73.100W.24.SNP	164x56x17mm
T73.150W.24.DIM	220x40x50mm	T73.150W.24.SNP	179x63x30mm
T73.240W.24.DIM	244x40x50mm	T73.200W.24.SNP	195x67x31mm
T73.320W.24.DIM	255x40x50mm	T73.320W.24.SNP	215x77x35 mm

Linear profiles

Profili lineari
Lineare profile
Perfiles lineales
Линейные контуры

T311.10 / T311.10D / T311.11 / T311.11D Pirgos - p. 70

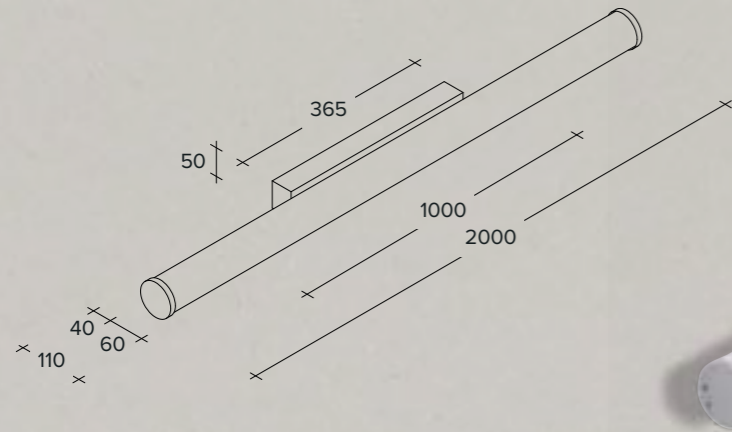

Opal polymeric wall/ceiling lamp.
Grey painted aluminium base with built-in power supply.

Designed by **Tecnico R&D**

Material / Materiale / Material / Material / Material / Material / **Aluminum and opal / Alluminio e opale / Aluminium und Opal / Aluminium u ópalo / Алюминий и опал**

Light source / Fonte di luce / Lichtquelle / Fuente de luz / Источник света
LED (19.2 W/m)

Type-approvals / Omologazioni / Zulassungen / Homologaciones / Разрешения
CE  IP40

T311.10	T311.10.D	T311.11	T311.11.D
1000 mm		2000 mm	
19.2 W		38.4 W	
24 V		24 V	
3000 °K		3000 °K	
2000 Lumen		4000 Lumen	
-	Dimmable / Dimmerabile / Dimmerfähig / Intensidad regulable / С регулируемой яркостью	-	Dimmable / Dimmerabile / Dimmerfähig / Intensidad regulable / С регулируемой яркостью

*Dimmable with normally open button
*Dimmerabile con pulsante normalmente aperto
*Dimmerbar mit taste normalerweise offen
*Intensidad luminosa no regulable con pulsador normalmente abierto
*Диммируется с помощью технологий нормально разомкнутый контакт



T311.30 / T311.30D / T311.31 / T311.31D Pirgos - p. 72

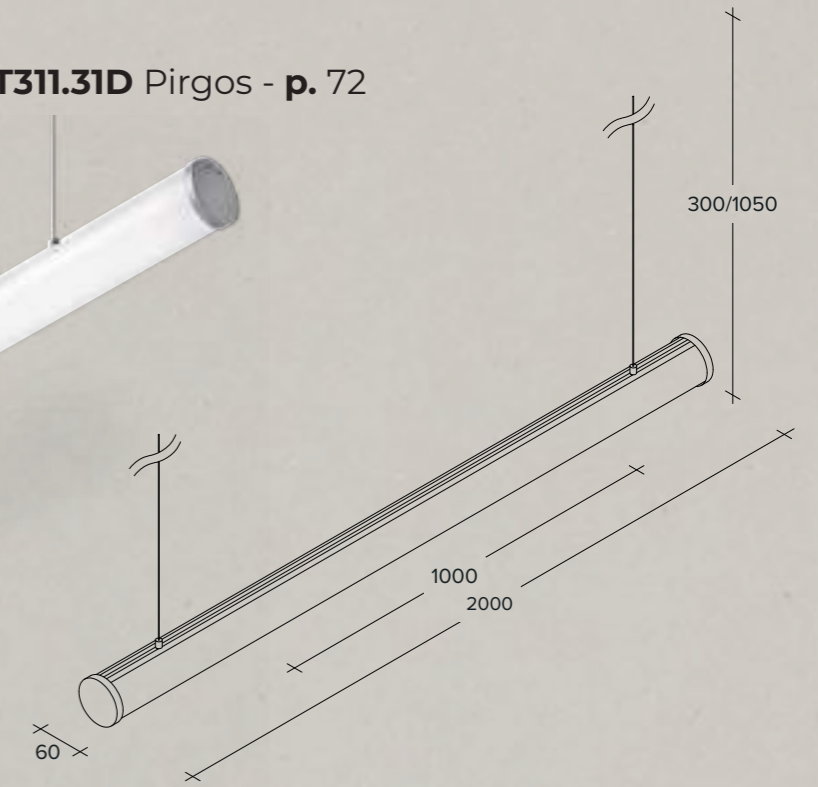

Opal polymeric suspension lamp.
Grey painted aluminium base with built-in power supply.

Designed by **Tecnico R&D**

Material / Materiale / Material / Material / Material / Material / **Aluminum and opal / Alluminio e opale / Aluminium und Opal / Aluminium u ópalo / Алюминий и опал**

Light source / Fonte di luce / Lichtquelle / Fuente de luz / Источник света
LED (19.2 W/m)

Type-approvals / Omologazioni / Zulassungen / Homologaciones / Разрешения
CE  IP40

T311.30	T311.30.D	T311.31	T311.31.D
1000 mm		2000 mm	
19.2 W		38.4 W	
24 V		24 V	
3000 °K		3000 °K	
2000 Lumen		4000 Lumen	
-	Dimmable / Dimmerabile / Dimmerfähig / Intensidad regulable / С регулируемой яркостью	-	Dimmable / Dimmerabile / Dimmerfähig / Intensidad regulable / С регулируемой яркостью

*Dimmable with normally open button
*Dimmerabile con pulsante normalmente aperto
*Dimmerbar mit taste normalerweise offen
*Intensidad luminosa no regulable con pulsador normalmente abierto
*Диммируется с помощью технологий нормально разомкнутый контакт





T311.50 Pirgos - p. 74

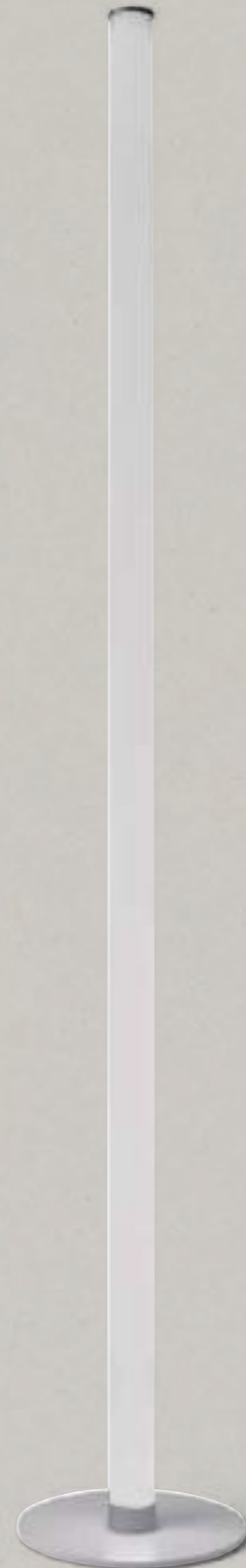

Opal polymeric floor lamp with grey painted metal base with built-in dimmable power supply

Designed by	Tecnico R&D
Material / Materiale / Material / Material / Material / Материал	Aluminum and opal / Alluminio e opale / Aluminium und Opal / Aluminium u ópalu / Алюминий и опал
Light source / Fonte di luce / Lichtquelle / Fuente de luz / Источник света	LED (19,2 W/m)
Type-approvals / Omologazioni / Zulassungen / Homologaciones / Разрешения	CE   IP40

T311.50

2000 mm

38.4 W

24 V

3000 °K

4000 Lumen

Foot operated dimmer switch / Dimmer a piede / Fußdimmer / Regulador de intensidad de pie / диммер с ножным управлением

Recessed plaster ceiling lighting

Lampade da incasso in gesso
Einbau aus gips an der decke
Empotrables de yeso para techo
Встраиваемые потолочные светильники из гипса

T332 Thessaly - p. 80
Aluminium ring - **Matte black**



T334 Thessaly - p. 81
Aluminium ring - **Matte black**



T390 Thessaly Raso - p. 88
Aluminium ring - **Matte black**



T391 Thessaly Raso - p. 89
Aluminium ring - **Matte white**



T335 Thessaly - p. 82
Aluminium ring - **Brushed brass**



T336 Thessaly - p. 83
Aluminium ring - **Brushed copper**



T392 Thessaly Raso - p. 90
Aluminium ring - **Brushed brass**



T393 Thessaly Raso - p. 91
Aluminium ring - **Brushed copper**



T408 Thessaly - p. 84
Aluminium ring - **Brushed aluminium**



T409 Thessaly - p. 85
Aluminium ring - **Brushed bronze**



T410 Thessaly Raso - p. 92
Aluminium ring - **Brushed aluminium**



T411 Thessaly Raso - p. 93
Aluminium ring - **Brushed bronze**

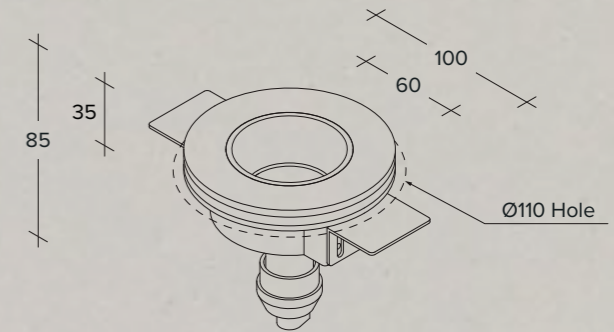
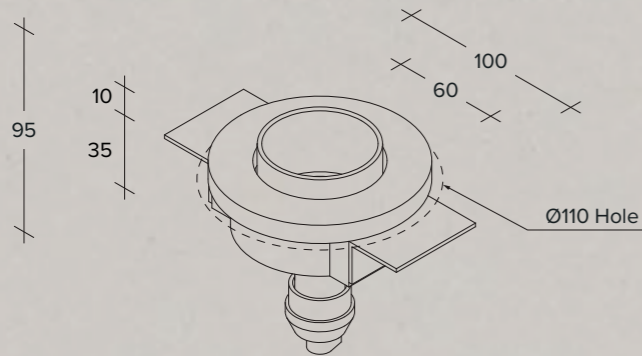



Recessed plaster spotlight with aluminium ring

Designed by **_blank design studio**

Material / Materiale / Material / Material / Material / Материал
Plaster and aluminium / Gesso e alluminio / Gips und Aluminium / Yeso y aluminio / Гипс и алюминий

Light source / Fonte di luce / Lichtquelle / Fuente de luz / Источник света
GU10
1 x 40W

Type-approvals / Omologazioni / Zulassungen / Homologaciones / Разрешения
CE  





Flush recessed plaster spotlight with aluminium ring

Designed by **_blank design studio**

Material / Materiale / Material / Material / Material / Материал
Plaster and aluminium / Gesso e alluminio / Gips und Aluminium / Yeso y aluminio / Гипс и алюминий

Light source / Fonte di luce / Lichtquelle / Fuente de luz / Источник света
GU10
1 x 40W

Type-approvals / Omologazioni / Zulassungen / Homologaciones / Разрешения
CE  



T418 Elis - p. 96

Aluminium frame - **Matte black**



T419 Elis - p. 97

Aluminium frame - **Matte white**



T414 Elis Raso - p. 102

Aluminium frame - **Matte black**



T415 Elis Raso - p. 103

Aluminium frame - **Matte white**



T420 Elis - p. 98

Aluminium frame - **Brushed brass**



T421 Elis - p. 99

Aluminium frame - **Brushed copper**



T416 Elis Raso - p. 104

Aluminium frame - **Brushed brass**



T417 Elis Raso - p. 105

Aluminium frame - **Brushed copper**

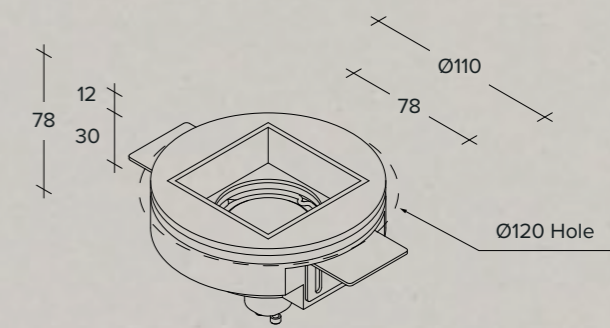
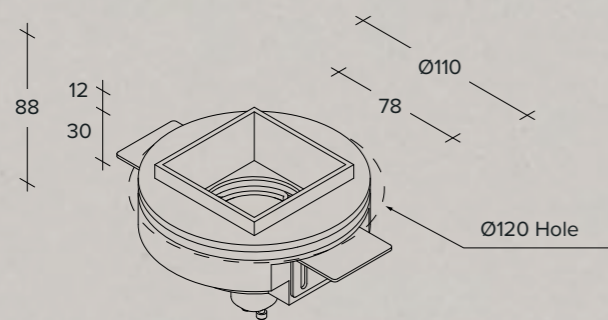

Recessed plaster spotlight with aluminium element

Designed by _blank design studio

Material / Materiale / Material / Material / Материал Plaster and aluminium / Gesso e alluminio / Gips und Aluminium / Yeso y aluminio / Гипс и алюминий

Light source / Fonte di luce / Lichtquelle / Fuente de luz / Источник света GU10 1 x 40W

Type-approvals / Omologazioni / Zulassungen / Homologaciones / Разрешения CE F OK LED BULB OK

Recessed plaster spotlight with aluminium element

Designed by _blank design studio

Material / Materiale / Material / Material / Материал Plaster and aluminium / Gesso e alluminio / Gips und Aluminium / Yeso y aluminio / Гипс и алюминий

Light source / Fonte di luce / Lichtquelle / Fuente de luz / Источник света GU10 1 x 40W

Type-approvals / Omologazioni / Zulassungen / Homologaciones / Разрешения CE F OK LED BULB OK

T464 Rhodia - p. 108
Aluminium ring - **Matte black**



T465 Rhodia - p. 109
Aluminium ring - **Matte white**



T468 Rhodia - p. 114
Aluminium ring - **Matte black**

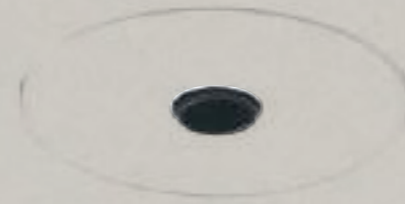

T469 Rhodia - p. 115
Aluminium ring - **Matte white**



T466 Rhodia - p. 110
Aluminium ring - **Brushed brass**



T467 Rhodia - p. 111
Aluminium ring - **Brushed copper**



T470 Rhodia - p. 116
Aluminium ring - **Brushed brass**



T471 Rhodia - p. 117
Aluminium ring - **Brushed copper**

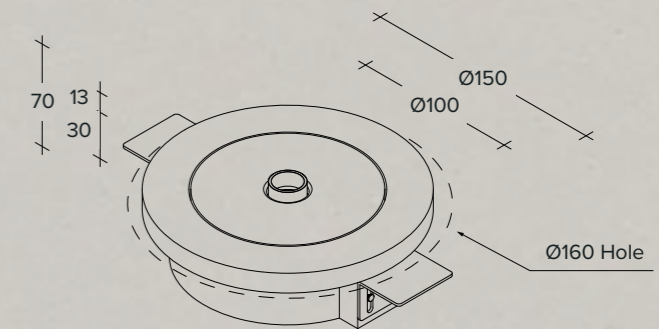
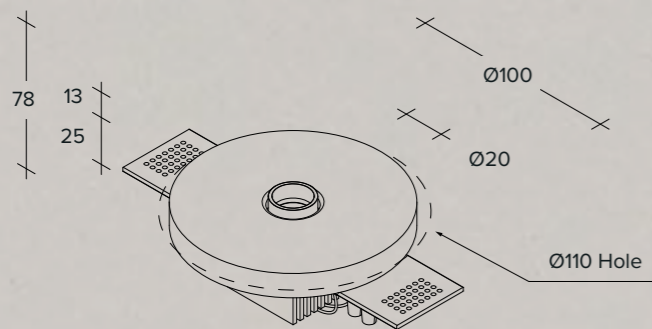

Recessed plaster lamp with aluminium ring.
20 mm diameter light point with built-in LED module.
Supplied with remote wiring power supply

Designed by **_blank design studio**

Material / Materiale / Material / Material / Материал
Plaster and aluminium / Gesso e alluminio / Gips und Aluminium / Yeso y aluminio / Гипс и алюминий

Light source / Fonte di luce / Lichtquelle / Fuente de luz / Источник света
LED Module 1 x 7 W

Type-approvals / Omologazioni / Zulassungen / Homologaciones / Разрешения
CE

Recessed plaster lamp with aluminium ring.
20 mm diameter light point with built-in LED module and power supply installed.

Designed by **_blank design studio**

Material / Materiale / Material / Material / Материал
Plaster and aluminium / Gesso e alluminio / Gips und Aluminium / Yeso y aluminio / Гипс и алюминий

Light source / Fonte di luce / Lichtquelle / Fuente de luz / Источник света
LED Module 1 x 10,5 W

Type-approvals / Omologazioni / Zulassungen / Homologaciones / Разрешения
CE

T479 Rhodia - p. 108
Aluminium ring - **Matte black**



T480 Rhodia - p. 109
Aluminium ring - **Matte white**



T483 Rhodia - p. 114
Aluminium ring - **Matte black**

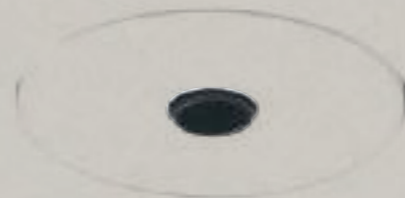

T484 Rhodia - p. 115
Aluminium ring - **Matte white**

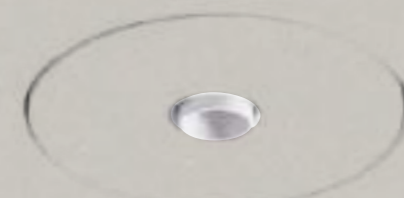

T481 Rhodia - p. 110
Aluminium ring - **Brushed brass**



T482 Rhodia - p. 111
Aluminium ring - **Brushed copper**







T485 Rhodia - p. 116
Aluminium ring - **Brushed brass**

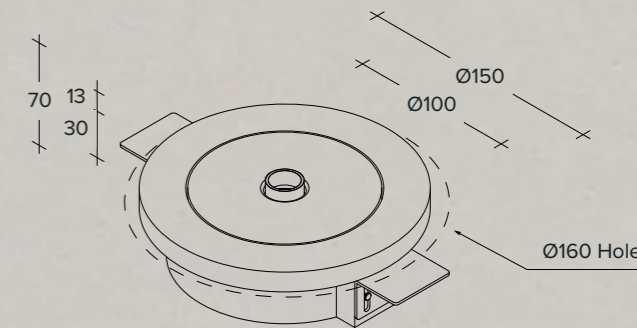
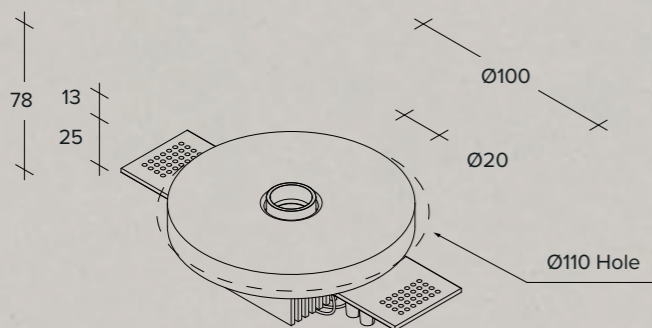





T486 Rhodia - p. 117
Aluminium ring - **Brushed copper**



Recessed plaster spotlight with aluminium ring.
Light element diameter 20 mm with integrated Triac dimmer LED module. Power supply included, to be remote cabled.
Once smoothed over, the spotlight - that can be installed in the plasterboard, blends into the structure.

Designed by	_blank design studio
Material / Materiale / Material / Material / Материал	Plaster and aluminium / Gesso e alluminio / Gips und Aluminium / Yeso y aluminio / Гипс и алюминий
	Dimmable / Dimmerabile / Dimmbar / Regulable / Диммируемый
Light source / Fonte di luce / Lichtquelle / Fuente de luz / Источник света	LED Module 1 x 7 W
Type-approvals / Omologazioni / Zulassungen / Homologaciones / Разрешения	   

Recessed plaster spotlight with aluminium ring.
Light element diameter 20 mm with integrated Triac dimmer LED module. Power supply included, to be remote cabled.
Once smoothed over, the spotlight - that can be installed in the plasterboard, blends into the structure.

Designed by	_blank design studio
Material / Materiale / Material / Material / Материал	Plaster and aluminium / Gesso e alluminio / Gips und Aluminium / Yeso y aluminio / Гипс и алюминий
	Dimmable / Dimmerabile / Dimmbar / Regulable / Диммируемый
Light source / Fonte di luce / Lichtquelle / Fuente de luz / Источник света	LED Module 1 x 10,5 W
Type-approvals / Omologazioni / Zulassungen / Homologaciones / Разрешения	   

T356 Lelanto - p. 120

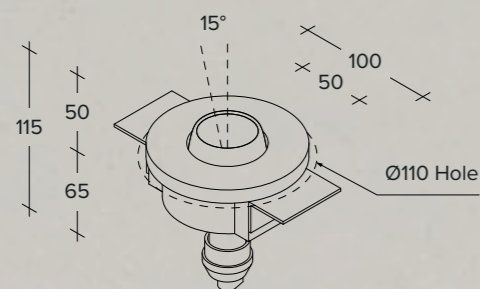

T412 Lelanto - p. 122

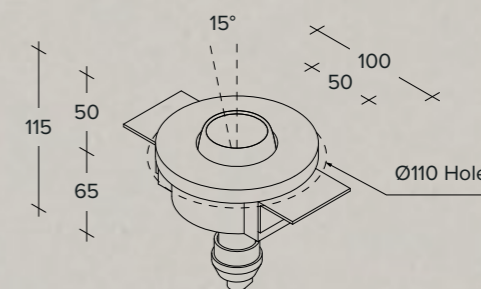

One-light adjustable recessed plasterboard spotlight with matte black painted ring finishing. Adjustable 15° tilt light.

Designed by	_blank design studio	
Material / Materiale / Material / Material / Материал	Plaster and aluminium / Gesso e alluminio / Gips und Aluminium / Yeso y aluminio / Гипс и алюминий	
Light source / Fonte di luce / Lichtquelle / Fuente de luz / Источник света	GU10 1 x 40W	
Type-approvals / Omologazioni / Zulassungen / Homologaciones / Разрешения		



One-light adjustable recessed plasterboard spotlight with matte white painted ring finishing. Adjustable 15° tilt light.

Designed by	_blank design studio	
Material / Materiale / Material / Material / Материал	Plaster and aluminium / Gesso e alluminio / Gips und Aluminium / Yeso y aluminio / Гипс и алюминий	
Light source / Fonte di luce / Lichtquelle / Fuente de luz / Источник света	GU10 1 x 40W	
Type-approvals / Omologazioni / Zulassungen / Homologaciones / Разрешения		

T357 Lelanto - p. 121

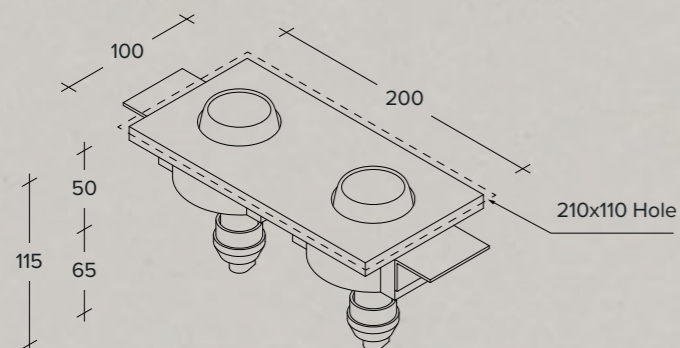

T413 Lelanto - p. 123

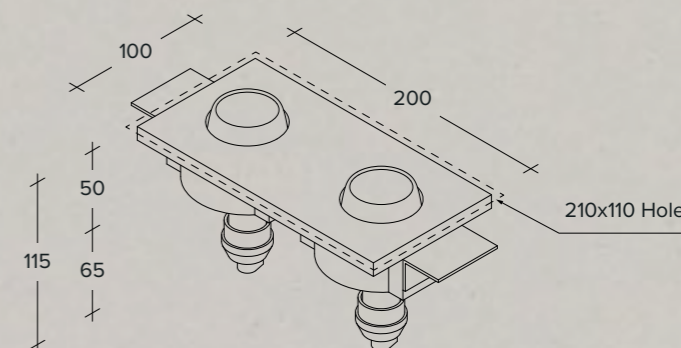

Two-lights adjustable recessed plasterboard spotlight with matte black painted ring finishing. Adjustable 15° tilt light.

Designed by	_blank design studio	
Material / Materiale / Material / Material / Материал	Plaster and aluminium / Gesso e alluminio / Gips und Aluminium / Yeso y aluminio / Гипс и алюминий	
Light source / Fonte di luce / Lichtquelle / Fuente de luz / Источник света	GU10 2 x 40W	
Type-approvals / Omologazioni / Zulassungen / Homologaciones / Разрешения		



Two-lights adjustable recessed plasterboard spotlight with matte white painted ring finishing. Adjustable 15° tilt light.

Designed by	_blank design studio	
Material / Materiale / Material / Material / Материал	Plaster and aluminium / Gesso e alluminio / Gips und Aluminium / Yeso y aluminio / Гипс и алюминий	
Light source / Fonte di luce / Lichtquelle / Fuente de luz / Источник света	GU10 2 x 40W	
Type-approvals / Omologazioni / Zulassungen / Homologaciones / Разрешения		

T337 Filiatrà - p. 126

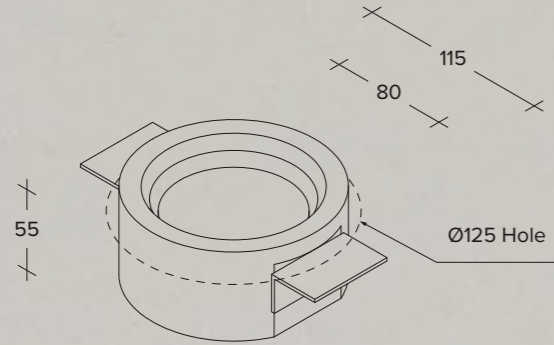

Recessed plaster spotlight

Designed by _blank design studio

Material / Materiale / Material / Material / Материал **Plaster / Gesso / Gips / Yeso / Гипсовый**

Light source / Fonte di luce / Lichtquelle / Fuente de luz / Источник света GX53 1 x 10 W

Type-approvals / Omologazioni / Zulassungen / Homologaciones / Разрешения CE F LED BULB OK

T381 Filiatrà - p. 128

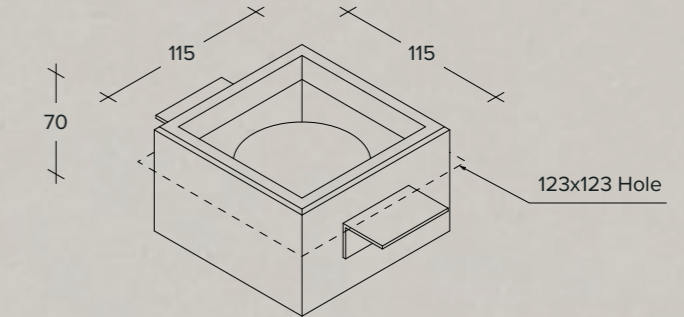
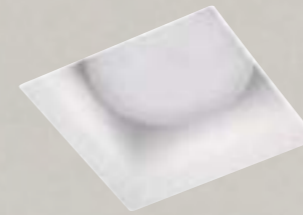

Recessed plaster spotlight

Designed by _blank design studio

Material / Materiale / Material / Material / Материал **Plaster / Gesso / Gips / Yeso / Гипсовый**

Light source / Fonte di luce / Lichtquelle / Fuente de luz / Источник света GX53 1 x 10 W

Type-approvals / Omologazioni / Zulassungen / Homologaciones / Разрешения CE F LED BULB OK

T338 Filiatrà - p. 127

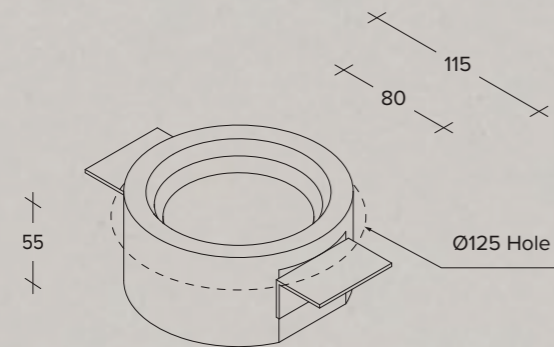

Recessed plaster spotlight with black painted inner edge

Designed by _blank design studio

Material / Materiale / Material / Material / Материал **Plaster and aluminium / Gesso e alluminio / Gips und Aluminium / Yeso y aluminio / Гипс и алюминий**

Light source / Fonte di luce / Lichtquelle / Fuente de luz / Источник света GX53 1 x 10 W

Type-approvals / Omologazioni / Zulassungen / Homologaciones / Разрешения CE F LED BULB OK

T382 Filiatrà - p. 129

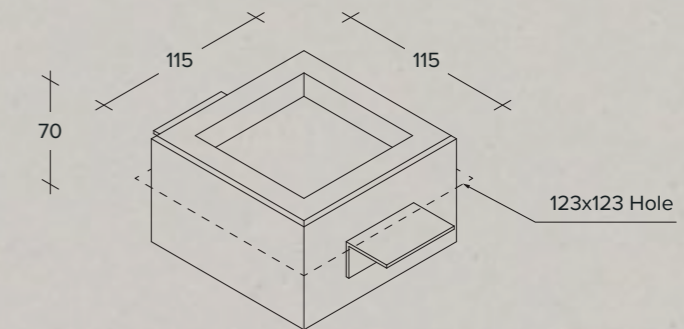
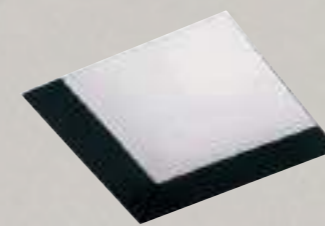

Recessed plaster spotlight with black painted inner edge and opal glass

Designed by _blank design studio

Material / Materiale / Material / Material / Материал **Plaster and glass / Gesso e vetro / Gips und Glas / Yeso y vidrio / Гипс и стекло**

Light source / Fonte di luce / Lichtquelle / Fuente de luz / Источник света GX53 1 x 10 W

Type-approvals / Omologazioni / Zulassungen / Homologaciones / Разрешения CE F LED BULB OK

T383 Filiatrà - p. 130

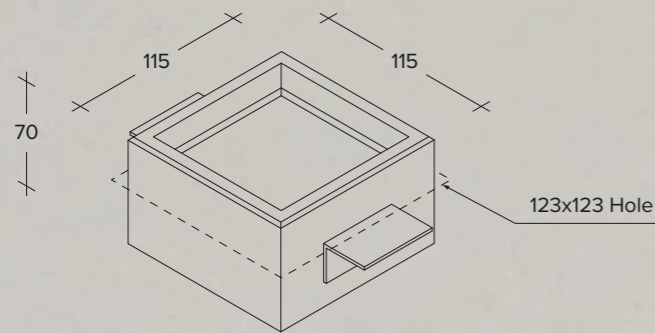

Recessed plaster spotlight with opal glass

Designed by **_blank design studio**

Material / Materiale / Material / Material / Материал **Plaster and glass / Gesso e vetro / Gips und Glas / Yeso y vidrio / Гипс и стекло**

Light source / Fonte di luce / Lichtquelle / Fuente de luz / Источник света **CX53
1 x 10 W**

Type-approvals / Omologazioni / Zulassungen / Homologaciones / Разрешения **CE F LED BULB OK**



T353 Doride - p. 138

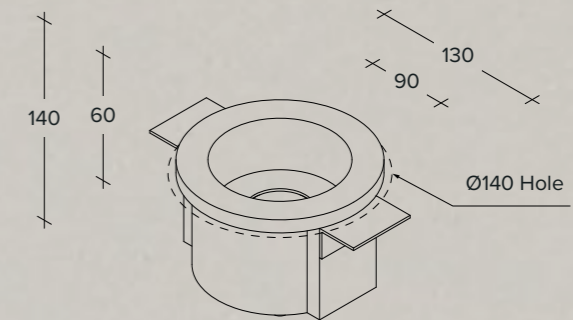

Recessed plaster spotlight. Internal metal housing with IP44 protection rating

Designed by **Tecnico R&D**

Material / Materiale / Material / Material / Материал **Plaster / Gesso / Gips / Yeso / Гипсовый**

Light source / Fonte di luce / Lichtquelle / Fuente de luz / Источник света **GU10
1 x 40W**

Type-approvals / Omologazioni / Zulassungen / Homologaciones / Разрешения **CE F IP44 LED BULB OK**



T384 Phocis - p. 132

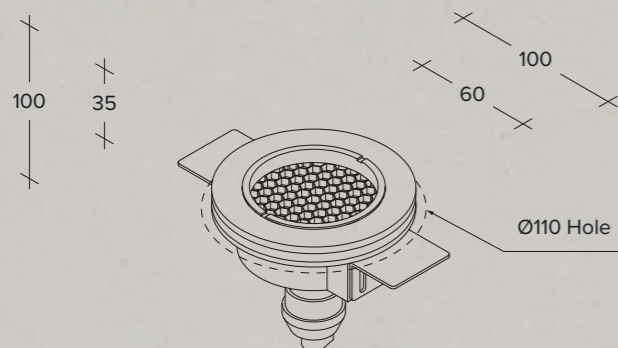

Recessed plaster spotlight with matte black painted ring and mesh finishing

Designed by **_blank design studio**

Material / Materiale / Material / Material / Материал **Plaster and aluminium / Gesso e alluminio / Gips und Aluminium / Yeso y aluminio / Гипс и алюминий**

Light source / Fonte di luce / Lichtquelle / Fuente de luz / Источник света **GU10
1 x 40W**

Type-approvals / Omologazioni / Zulassungen / Homologaciones / Разрешения **CE F LED BULB OK**

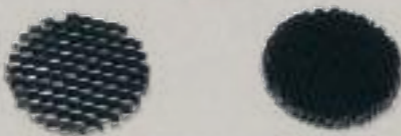

T354 Doride - p. 139

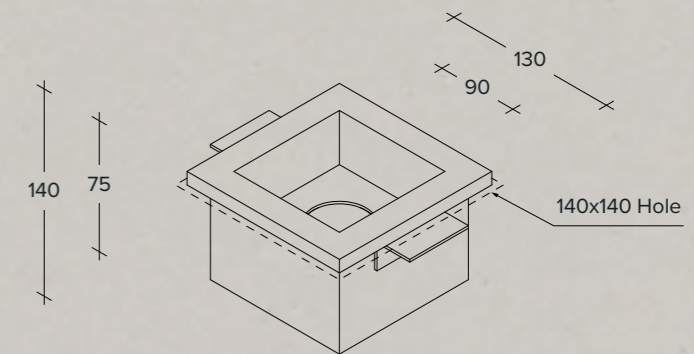

Recessed plaster spotlight. Internal metal housing with IP44 protection rating

Designed by **Tecnico R&D**

Material / Materiale / Material / Material / Материал **Plaster / Gesso / Gips / Yeso / Гипсовый**

Light source / Fonte di luce / Lichtquelle / Fuente de luz / Источник света **GU10
1 x 40W**

Type-approvals / Omologazioni / Zulassungen / Homologaciones / Разрешения **CE F IP44 LED BULB OK**



T255 Heraea - p. 142

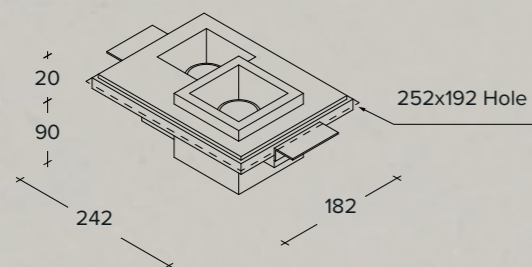

Two-lights recessed plaster spotlight

Designed by	Acero design studio
Material / Materiale / Material / Material / Материал	Plaster / Gesso / Gips / Yeso / Гипсовый
Light source / Fonte di luce / Lichtquelle / Fuente de luz / Источник света	GU10 2 x 40W
Type-approvals / Omologazioni / Zulassungen / Homologaciones / Разрешения	

T257 Heraea - p. 144

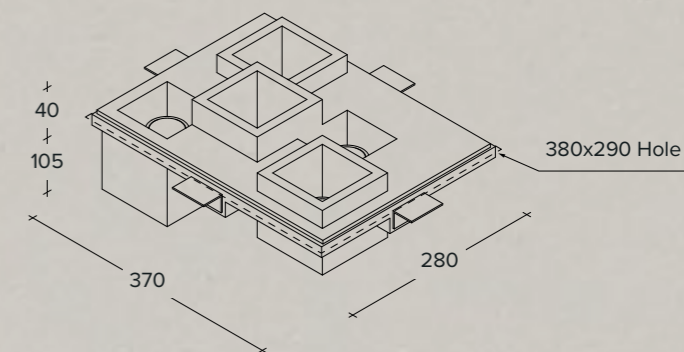

Five-lights recessed plaster spotlight

Designed by	Acero design studio
Material / Materiale / Material / Material / Материал	Plaster / Gesso / Gips / Yeso / Гипсовый
Light source / Fonte di luce / Lichtquelle / Fuente de luz / Источник света	GU10 5 x 40W
Type-approvals / Omologazioni / Zulassungen / Homologaciones / Разрешения	

T256 Heraea - p. 143

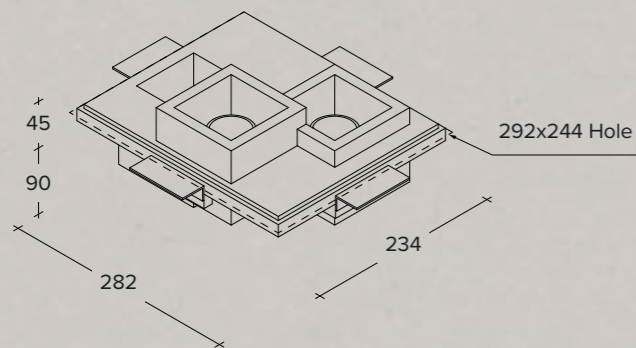

Three-lights recessed plaster spotlight

Designed by	Acero design studio
Material / Materiale / Material / Material / Материал	Plaster / Gesso / Gips / Yeso / Гипсовый
Light source / Fonte di luce / Lichtquelle / Fuente de luz / Источник света	GU10 3 x 40W
Type-approvals / Omologazioni / Zulassungen / Homologaciones / Разрешения	

T165 Siris - p. 147

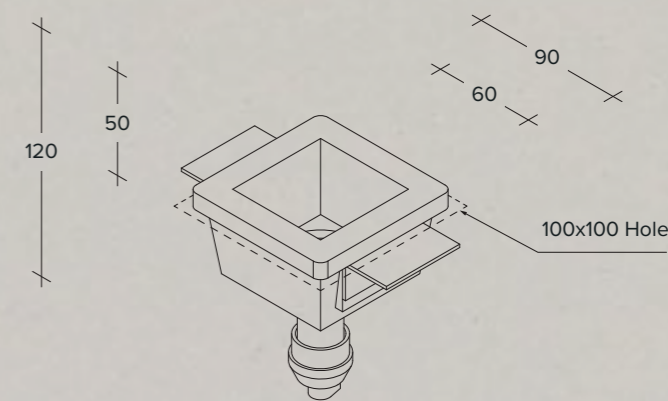

Recessed plaster spotlight

Designed by	Tecnico R&D
Material / Materiale / Material / Material / Материал	Plaster / Gesso / Gips / Yeso / Гипсовый
Light source / Fonte di luce / Lichtquelle / Fuente de luz / Источник света	GU10 1 x 40W
Type-approvals / Omologazioni / Zulassungen / Homologaciones / Разрешения	

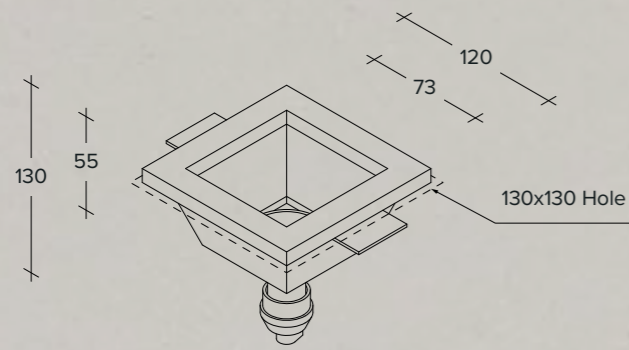

T04 Attica - p. 150

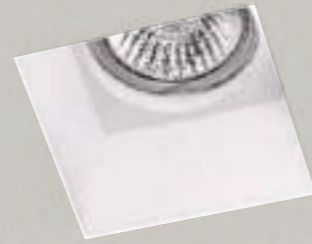

Recessed plaster spotlight

Designed by **Tecnico R&D**

Material / Materiale / Material / Material / Материал **Plaster / Gesso / Gips / Yeso / Гипсовый**

Light source / Fonte di luce / Lichtquelle / Fuente de luz / Источник света **GU10 1 x 40W**

Type-approvals / Omologazioni / Zulassungen / Homologaciones / Разрешения **CE F**



T177 Attica Orientabile - p. 152

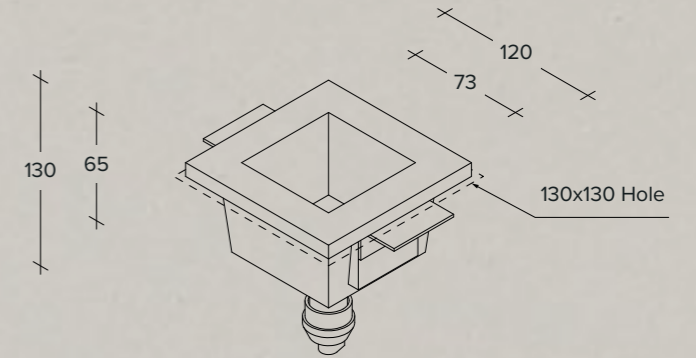

Recessed plaster spotlight with adjustable light point

Designed by **Tecnico R&D**

Material / Materiale / Material / Material / Материал **Plaster / Gesso / Gips / Yeso / Гипсовый**

Light source / Fonte di luce / Lichtquelle / Fuente de luz / Источник света **GU10 1 x 40W**

Type-approvals / Omologazioni / Zulassungen / Homologaciones / Разрешения **CE F**



T28 Attica Glass - p. 150

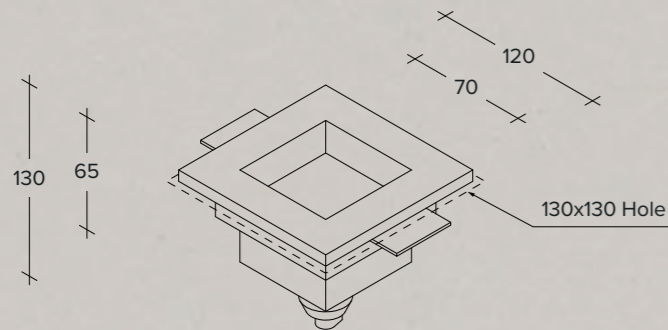

Invisible recessed fitting for false ceilings

Designed by **Tecnico R&D**

Material / Materiale / Material / Material / Материал **Plaster and glass / Gesso e vetro / Gips und Glas / Yeso y vidrio / Гипс и стекло**

Light source / Fonte di luce / Lichtquelle / Fuente de luz / Источник света **GU10 1 x 40W**

Type-approvals / Omologazioni / Zulassungen / Homologaciones / Разрешения **CE F**



Wall, ceiling and pendant lamps

Lampade da parete, a soffitto e a sospensione

Wand-, decken- und aufhängungsleuchten

Lámparas de pared, techo y colgantes

Настенные, потолочные и подвесные светильники

T406 Propilei - p. 158

T487 Propilei - p. 162

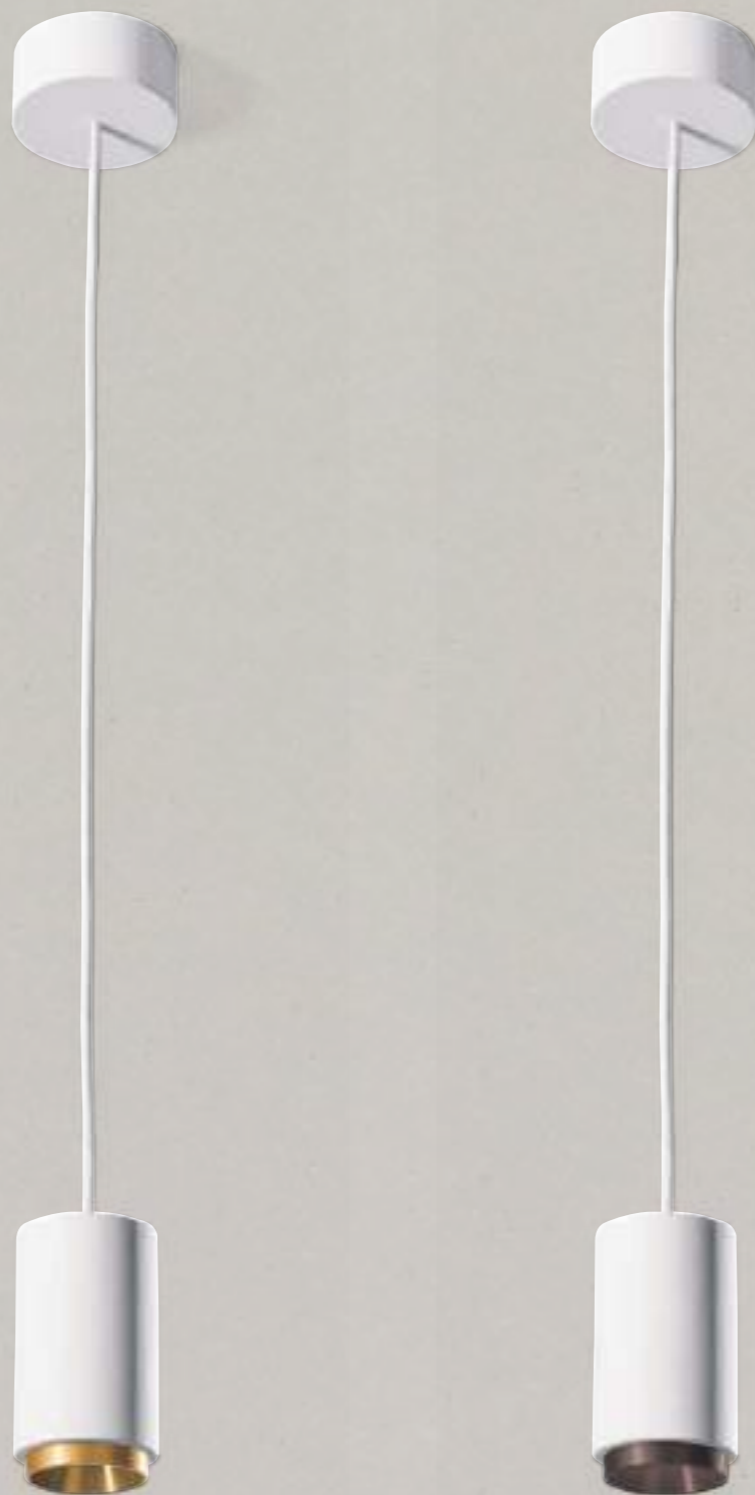
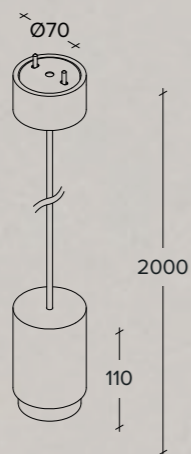



Plaster suspension lamp with aluminium ring in different finishings

Designed by **_blank design studio**

Material / Materiale / Material / Material / Материал
Plaster and aluminium / Gesso e alluminio / Gips und Aluminium / Yeso y aluminio / Гипс и алюминий

Light source / Fonte di luce / Lichtquelle / Fuente de luz / Источник света
 GU10
 1 x 40W

Type-approvals / Omologazioni / Zulassungen / Homologaciones / Разрешения
  

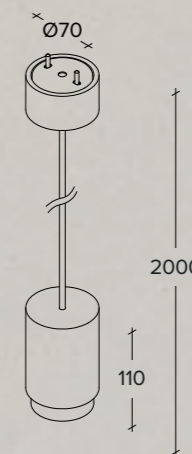



Plaster suspension lamp with aluminium ring in different finishings

Designed by **_blank design studio**

Material / Materiale / Material / Material / Материал
Plaster and aluminium / Gesso e alluminio / Gips und Aluminium / Yeso y aluminio / Гипс и алюминий

Light source / Fonte di luce / Lichtquelle / Fuente de luz / Источник света
 GU10
 1 x 40W

Type-approvals / Omologazioni / Zulassungen / Homologaciones / Разрешения
  

T407 Propilei - p. 164

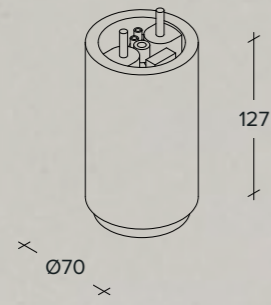



Plaster ceiling lamp with aluminium ring in different finishings

Designed by **_blank design studio**

Material / Materiale / Material / Material / Материал **Plaster and aluminium / Gesso e alluminio / Gips und Aluminium / Yeso y aluminio / Гипс и алюминий**

Light source / Fonte di luce / Lichtquelle / Fuente de luz / Источник света GU10
1 x 40W

Type-approvals / Omologazioni / Zulassungen / Homologaciones / Разрешения   



T488 Propilei - p. 168

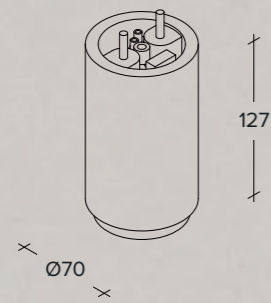



Plaster ceiling lamp with aluminium ring in different finishings

Designed by **_blank design studio**

Material / Materiale / Material / Material / Материал **Plaster and aluminium / Gesso e alluminio / Gips und Aluminium / Yeso y aluminio / Гипс и алюминий**

Light source / Fonte di luce / Lichtquelle / Fuente de luz / Источник света GU10
1 x 40W

Type-approvals / Omologazioni / Zulassungen / Homologaciones / Разрешения   



T426 Nasso quadrata - p. 172
Aluminium frame - **Matte black**



T427 Nasso quadrata - p. 173
Aluminium frame - **Matte white**



T434 Nasso quadrata - p. 176
Aluminium frame - **Matte black**



T435 Nasso quadrata - p. 177
Aluminium frame - **Matte white**



T428 Nasso quadrata - p. 174
Aluminium frame - **Brushed brass**

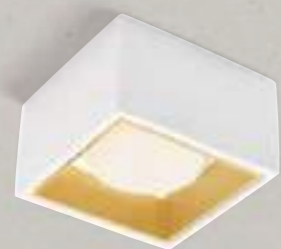

T429 Nasso quadrata - p. 175
Aluminium frame - **Brushed copper**



T436 Nasso quadrata - p. 178
Aluminium frame - **Brushed brass**



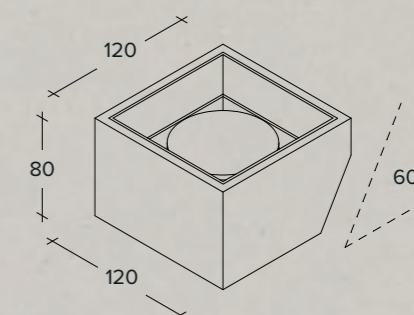
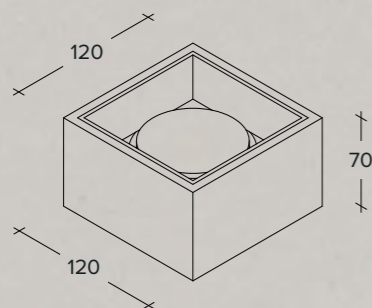

T437 Nasso quadrata - p. 179
Aluminium frame - **Brushed copper**



Plaster ceiling lamp with aluminium element in different finishings

Plaster wall lamp with aluminium element in different finishings

Designed by	_blank design studio
Material / Materiale / Material / Material / Материал	Plaster and aluminium / Gesso e alluminio / Gips und Aluminium / Yeso y aluminio / Гипс и алюминий
Light source / Fonte di luce / Lichtquelle / Fuente de luz / Источник света	GX53 1 x 10W
Type-approvals / Omologazioni / Zulassungen / Homologaciones / Разрешения	  

Designed by	_blank design studio
Material / Materiale / Material / Material / Материал	Plaster and aluminium / Gesso e alluminio / Gips und Aluminium / Yeso y aluminio / Гипс и алюминий
Light source / Fonte di luce / Lichtquelle / Fuente de luz / Источник света	GX53 1 x 10W
Type-approvals / Omologazioni / Zulassungen / Homologaciones / Разрешения	  

T422 Nasso tonda - p. 182
Aluminium ring - **Matte black**



T423 Nasso tonda - p. 183
Aluminium ring - **Matte white**



T430 Nasso tonda - p. 186
Aluminium ring - **Matte black**



T431 Nasso tonda - p. 187
Aluminium ring - **Matte white**



T424 Nasso tonda - p. 184
Aluminium ring - **Brushed brass**



T425 Nasso tonda - p. 185
Aluminium ring - **Brushed copper**







T432 Nasso tonda - p. 188
Aluminium ring - **Brushed brass**

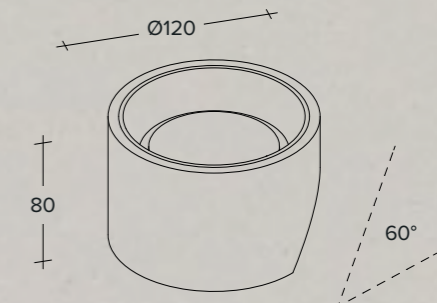
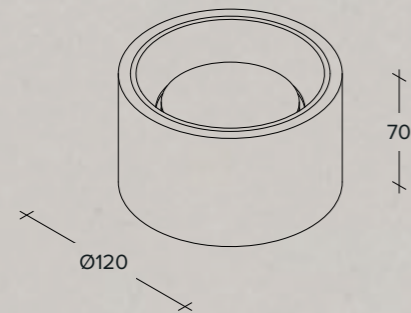





T433 Nasso tonda - p. 189
Aluminium ring - **Brushed copper**



Plaster ceiling lamp with aluminium ring in different finishings

Designed by	_blank design studio
Material / Materiale / Material / Material / Материал	Plaster and aluminium / Gesso e alluminio / Gips und Aluminium / Yeso y aluminio / Гипс и алюминий
Light source / Fonte di luce / Lichtquelle / Fuente de luz / Источник света	GX53 1 x 10W
Type-approvals / Omologazioni / Zulassungen / Homologaciones / Разрешения	   

Plaster wall lamp with aluminium ring in different finishings

Designed by	_blank design studio
Material / Materiale / Material / Material / Материал	Plaster and aluminium / Gesso e alluminio / Gips und Aluminium / Yeso y aluminio / Гипс и алюминий
Light source / Fonte di luce / Lichtquelle / Fuente de luz / Источник света	GX53 1 x 10W
Type-approvals / Omologazioni / Zulassungen / Homologaciones / Разрешения	   

T442 Syme quadrata - p. 192
Aluminium frame - **Matte black**



T443 Syme quadrata - p. 193
Aluminium frame - **Matte white**



T450 Syme quadrata - p. 196
Aluminium frame - **Matte black**



T451 Syme quadrata - p. 197
Aluminium frame - **Matte white**



T444 Syme quadrata - p. 194
Aluminium frame - **Brushed brass**



T445 Syme quadrata - p. 195
Aluminium frame - **Brushed copper**





T452 Syme quadrata - p. 198
Aluminium frame - **Brushed brass**

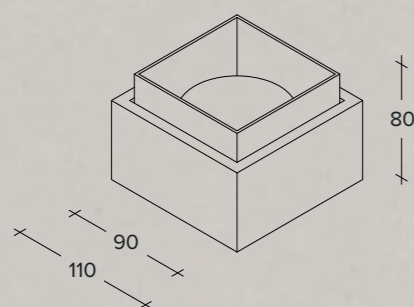

T453 Syme quadrata - p. 199
Aluminium frame - **Brushed copper**



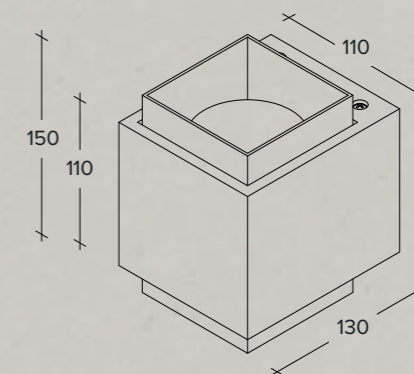

Plaster ceiling lamp with aluminium element in different finishings

Designed by	_blank design studio
Material / Materiale / Material / Material / Материал	Plaster and aluminium / Gesso e alluminio / Gips und Aluminium / Yeso y aluminio / Гипс и алюминий
Light source / Fonte di luce / Lichtquelle / Fuente de luz / Источник света	GX53 1 x 10W
Type-approvals / Omologazioni / Zulassungen / Homologaciones / Разрешения	  



Plaster wall lamp for indirect lighting with aluminium element in different finishings

Designed by	_blank design studio
Material / Materiale / Material / Material / Материал	Plaster and aluminium / Gesso e alluminio / Gips und Aluminium / Yeso y aluminio / Гипс и алюминий
Light source / Fonte di luce / Lichtquelle / Fuente de luz / Источник света	GX53 2 x 10W
Type-approvals / Omologazioni / Zulassungen / Homologaciones / Разрешения	  

T438 Syme tonda - p. 202
Aluminium ring - **Matte black**



T439 Syme tonda - p. 203
Aluminium ring - **Matte white**



T446 Syme tonda - p. 206
Aluminium ring - **Matte black**



T447 Syme tonda - p. 207
Aluminium ring - **Matte white**



T440 Syme tonda - p. 204
Aluminium ring - **Brushed brass**



T441 Syme tonda - p. 205
Aluminium ring - **Brushed copper**







T448 Syme tonda - p. 208
Aluminium ring - **Brushed brass**

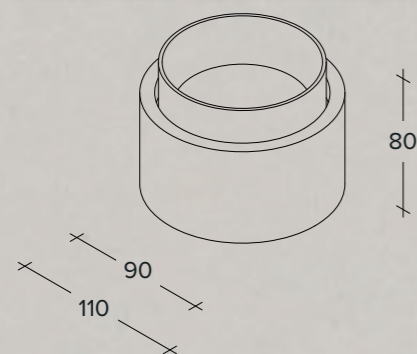

T449 Syme tonda - p. 209
Aluminium ring - **Brushed copper**





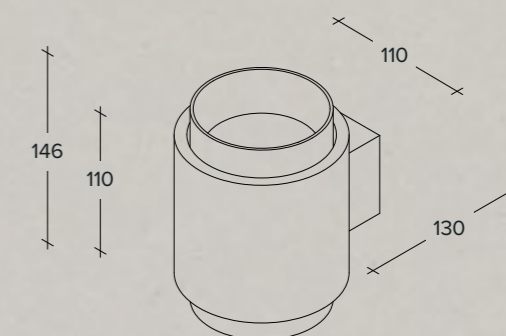

Plaster ceiling lamp with aluminium ring in different finishings

Designed by	_blank design studio
Material / Materiale / Material / Material / Материал	Plaster and aluminium / Gesso e alluminio / Gips und Aluminium / Yeso y aluminio / Гипс и алюминий
Light source / Fonte di luce / Lichtquelle / Fuente de luz / Источник света	GX53 1 x 10W
Type-approvals / Omologazioni / Zulassungen / Homologaciones / Разрешения	   



Plaster wall lamp for indirect lighting with aluminium ring in different finishings

Designed by	_blank design studio
Material / Materiale / Material / Material / Материал	Plaster and aluminium / Gesso e alluminio / Gips und Aluminium / Yeso y aluminio / Гипс и алюминий
Light source / Fonte di luce / Lichtquelle / Fuente de luz / Источник света	GX53 2 x 10W
Type-approvals / Omologazioni / Zulassungen / Homologaciones / Разрешения	   

T457 Mysia - p. 216
Quartz gray

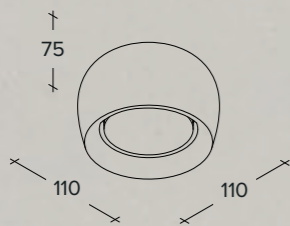

One-light plaster ceiling lamp white or Quartz gray (RAL 7039)

Designed by Acero Studio Design

Material / Materiale / Material / Material / Материал Plaster / Gesso / Gips / Yeso / Гипсовый

Light source / Fonte di luce / Lichtquelle / Fuente de luz / Источник света GX53
1 x 10W

Type-approvals / Omologazioni / Zulassungen / Homologaciones / Разрешения CE F ⊕ LED BULB OK

T454 Mysia - p. 212
White



T456 Mysia - p. 214
White



T459 Mysia - p. 218
Quartz gray

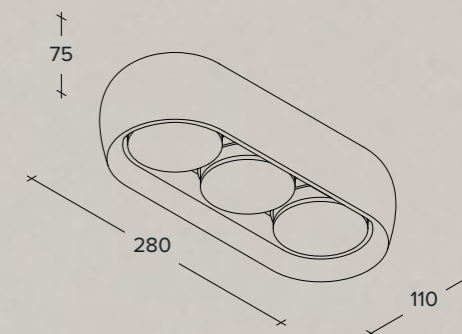

Three-light plaster ceiling lamp white or Quartz gray (RAL 7039)

Designed by Acero Studio Design

Material / Materiale / Material / Material / Материал Plaster / Gesso / Gips / Yeso / Гипсовый

Light source / Fonte di luce / Lichtquelle / Fuente de luz / Источник света GX53
3 x 10W

Type-approvals / Omologazioni / Zulassungen / Homologaciones / Разрешения CE F ⊕ LED BULB OK

T458 Mysia - p. 217
Quartz gray

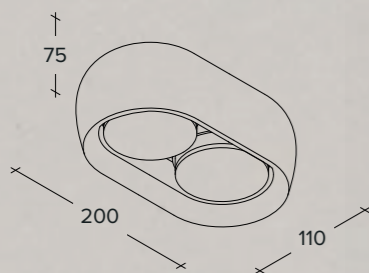

Two-light plaster ceiling lamp white or Quartz gray (RAL 7039)

Designed by Acero Studio Design

Material / Materiale / Material / Material / Материал Plaster / Gesso / Gips / Yeso / Гипсовый

Light source / Fonte di luce / Lichtquelle / Fuente de luz / Источник света GX53
2 x 10W

Type-approvals / Omologazioni / Zulassungen / Homologaciones / Разрешения CE F ⊕ LED BULB OK

T455 Mysia - p. 213
White



T462 Mysis - p. 224
Quartz gray

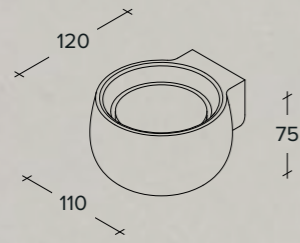



One-light plaster wall lamp white or Quartz gray (RAL 7039)

Designed by **Acero Studio Design**

Material / Materiale / Material / Material / Материал **Plaster / Gesso / Gips / Yeso / Гипсовый**

Light source / Fonte di luce / Lichtquelle / Fuente de luz / Источник света **GX53
1 x 10W**

Type-approvals / Omologazioni / Zulassungen / Homologaciones / Разрешения **CE**  

T460 Mysis - p. 220
White



T477 Mysis - p. 222
White



T478 Mysis - p. 226
Quartz gray

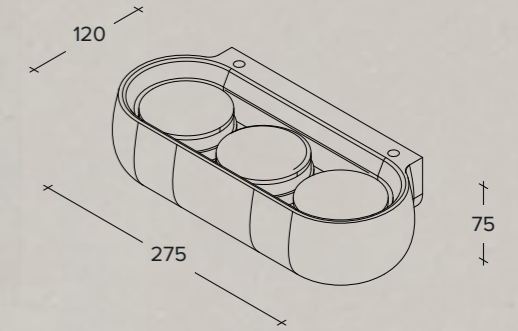



Three-light plaster wall lamp white or Quartz gray (RAL 7039)

Designed by **Acero Studio Design**

Material / Materiale / Material / Material / Материал **Plaster / Gesso / Gips / Yeso / Гипсовый**

Light source / Fonte di luce / Lichtquelle / Fuente de luz / Источник света **GX53
3 x 10W**

Type-approvals / Omologazioni / Zulassungen / Homologaciones / Разрешения **CE**  

T463 Mysis - p. 225
Quartz gray

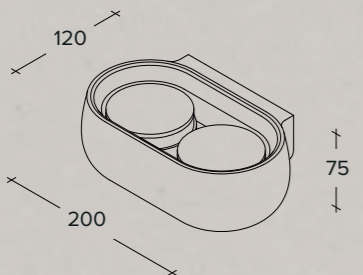

T461 Mysis - p.221
White





Two-light plaster wall lamp white or Quartz gray (RAL 7039)

Designed by **Acero Studio Design**

Material / Materiale / Material / Material / Материал **Plaster / Gesso / Gips / Yeso / Гипсовый**

Light source / Fonte di luce / Lichtquelle / Fuente de luz / Источник света **GX53
2 x 10W**

Type-approvals / Omologazioni / Zulassungen / Homologaciones / Разрешения **CE**  

T472 Milet - p. 230

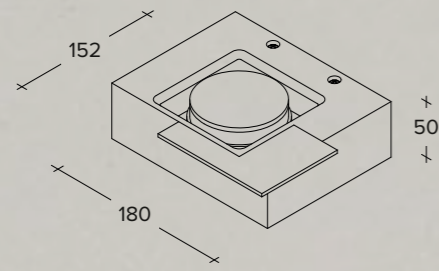



Plaster wall lamp with Quartz Grey (RAL 7039) painted aluminium element

Designed by **_blank design studio**

Material / Materiale / Material / Material / Материал **Plaster and aluminium / Gesso e alluminio / Gips und Aluminium / Yeso y aluminio / Гипс и алюминий**

Light source / Fonte di luce / Lichtquelle / Fuente de luz / Источник света **GX53
1 x 10W**

Type-approvals / Omologazioni / Zulassungen / Homologaciones / Разрешения **CE**  

T474 Milet - p. 232

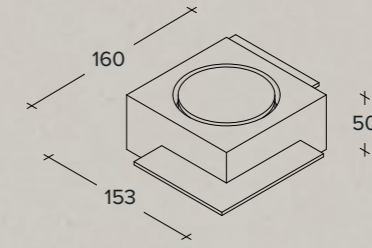



Plaster ceiling lamp with Quartz Grey (RAL 7039) painted aluminium element

Designed by **_blank design studio**

Material / Materiale / Material / Material / Материал **Plaster and aluminium / Gesso e alluminio / Gips und Aluminium / Yeso y aluminio / Гипс и алюминий**

Light source / Fonte di luce / Lichtquelle / Fuente de luz / Источник света **GX53
1 x 10W**

Type-approvals / Omologazioni / Zulassungen / Homologaciones / Разрешения **CE**  

T473 Milet - p. 231

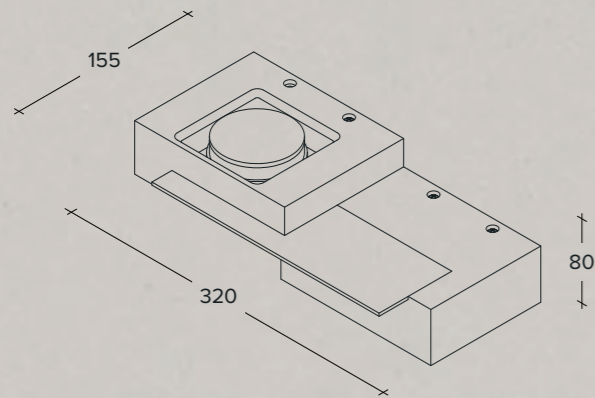



Plaster wall lamp with Quartz Grey (RAL 7039) painted aluminium element

Designed by **_blank design studio**

Material / Materiale / Material / Material / Материал **Plaster and aluminium / Gesso e alluminio / Gips und Aluminium / Yeso y aluminio / Гипс и алюминий**

Light source / Fonte di luce / Lichtquelle / Fuente de luz / Источник света **GX53
2 x 10W**

Type-approvals / Omologazioni / Zulassungen / Homologaciones / Разрешения **CE**  

T475 Milet - p. 233

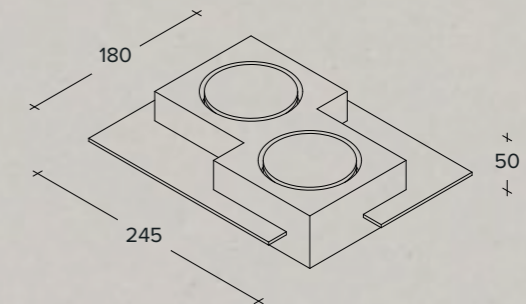



Plaster ceiling lamp with Quartz Grey (RAL 7039) painted aluminium element

Designed by **_blank design studio**

Material / Materiale / Material / Material / Материал **Plaster and aluminium / Gesso e alluminio / Gips und Aluminium / Yeso y aluminio / Гипс и алюминий**

Light source / Fonte di luce / Lichtquelle / Fuente de luz / Источник света **GX53
2 x 10W**

Type-approvals / Omologazioni / Zulassungen / Homologaciones / Разрешения **CE**  

T476 Milet - p. 234

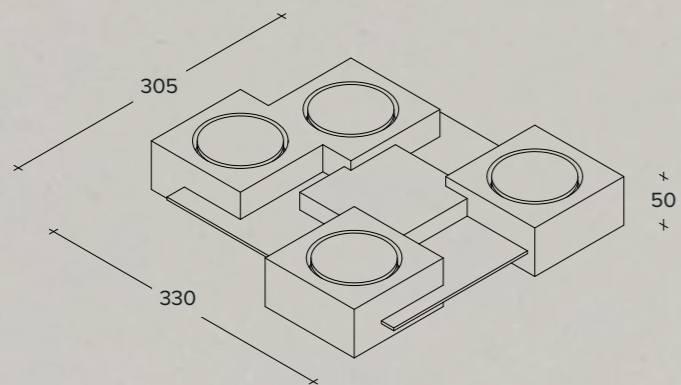

Plaster ceiling lamp with Quartz Grey (RAL 7039) painted aluminium element

Designed by	_blank design studio	
Material / Materiale / Material / Material / Материал	Plaster and aluminium / Gesso e alluminio / Gips und Aluminium / Yeso y aluminio / Гипс и алюминий	
Light source / Fonte di luce / Lichtquelle / Fuente de luz / Источник света	GX53 4 x 10W	
Type-approvals / Omologazioni / Zulassungen / Homologaciones / Разрешения		

T404 Cicladi tonda- p. 239

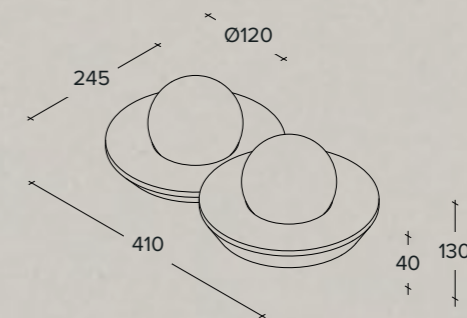

Plaster ceiling/wall lamp with one round blown glass (Modello depositato)

Designed by	_blank design studio	
Material / Materiale / Material / Material / Материал	Plaster and glass / Gesso e vetro / Gips und Glas / Yeso y vidrio / Гипс и стекло	
Light source / Fonte di luce / Lichtquelle / Fuente de luz / Источник света	GX53 2 x 10W	
Type-approvals / Omologazioni / Zulassungen / Homologaciones / Разрешения		

T403 Cicladi tonda - p. 238

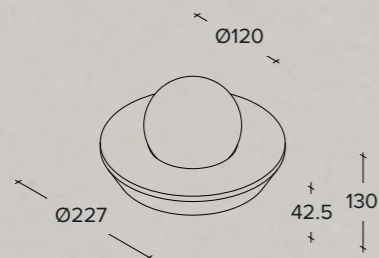

Plaster ceiling/wall lamp with one round blown glass (Modello depositato)

Designed by	_blank design studio	
Material / Materiale / Material / Material / Материал	Plaster and glass / Gesso e vetro / Gips und Glas / Yeso y vidrio / Гипс и стекло	
Light source / Fonte di luce / Lichtquelle / Fuente de luz / Источник света	GX53 1 x 10W	
Type-approvals / Omologazioni / Zulassungen / Homologaciones / Разрешения		

T405 Cicladi tonda- p. 240

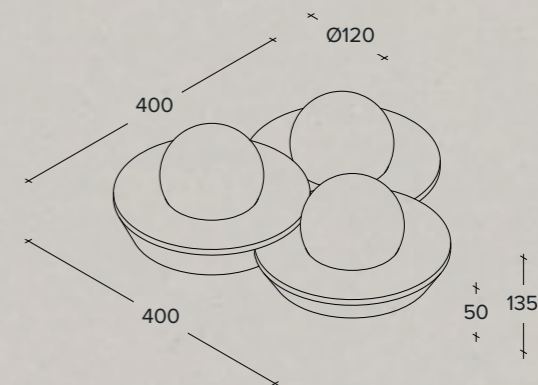

Plaster ceiling/wall lamp with one round blown glass (Modello depositato)

Designed by	_blank design studio	
Material / Materiale / Material / Material / Материал	Plaster and glass / Gesso e vetro / Gips und Glas / Yeso y vidrio / Гипс и стекло	
Light source / Fonte di luce / Lichtquelle / Fuente de luz / Источник света	GX53 3 x 10W	
Type-approvals / Omologazioni / Zulassungen / Homologaciones / Разрешения		

T385 Cicladi - p. 244

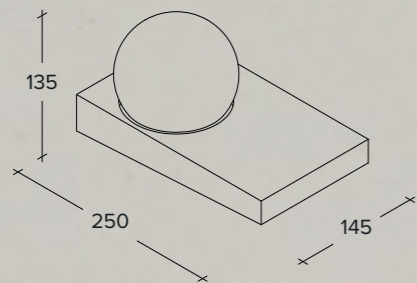

Plaster wall lamp with one round blown glass
(Modello depositato)

Designed by _blank design studio

Material / Materiale / Material / Material / Материал **Plaster and glass / Gesso e vetro / Gips und Glas / Yeso y vidrio / Гипс и стекло**

Light source / Fonte di luce / Lichtquelle / Fuente de luz / Источник света GX53
1 x 10W

Type-approvals / Omologazioni / Zulassungen / Homologaciones / Разрешения CE

T396 Cicladi - p. 247

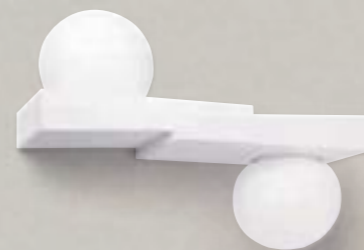
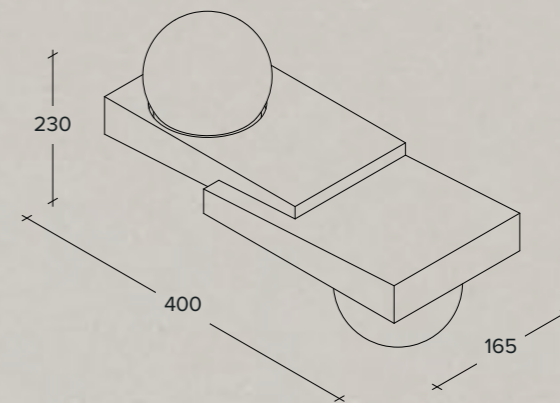

Up/down lights plaster wall lamp with two round blown glass
(Modello depositato)

Designed by _blank design studio

Material / Materiale / Material / Material / Материал **Plaster and glass / Gesso e vetro / Gips und Glas / Yeso y vidrio / Гипс и стекло**

Light source / Fonte di luce / Lichtquelle / Fuente de luz / Источник света GX53
2 x 10W

Type-approvals / Omologazioni / Zulassungen / Homologaciones / Разрешения CE

T386 Cicladi - p. 246

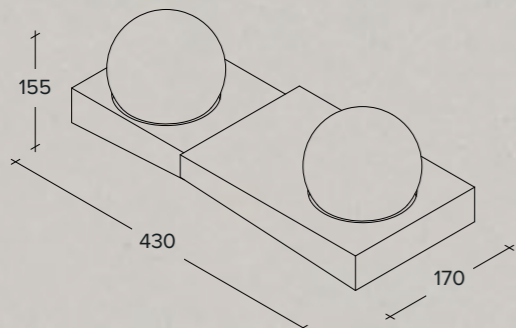

Plaster wall lamp with two round blown glass
(Modello depositato)

Designed by _blank design studio

Material / Materiale / Material / Material / Материал **Plaster and glass / Gesso e vetro / Gips und Glas / Yeso y vidrio / Гипс и стекло**

Light source / Fonte di luce / Lichtquelle / Fuente de luz / Источник света GX53
2 x 10W

Type-approvals / Omologazioni / Zulassungen / Homologaciones / Разрешения CE

T387 Cicladi - p. 248

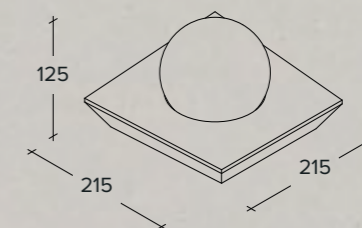

Plaster ceiling lamp with one round blown glass
(Modello depositato)

Designed by _blank design studio

Material / Materiale / Material / Material / Материал **Plaster and glass / Gesso e vetro / Gips und Glas / Yeso y vidrio / Гипс и стекло**

Light source / Fonte di luce / Lichtquelle / Fuente de luz / Источник света GX53
1 x 10W

Type-approvals / Omologazioni / Zulassungen / Homologaciones / Разрешения CE

T388 Cicladi - p. 249

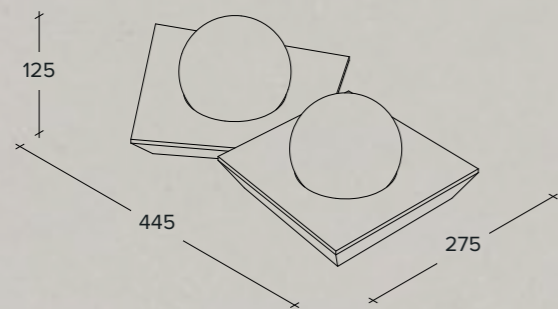

Plaster ceiling lamp with two round blown glass
(Modello depositato)

Designed by	_blank design studio	
Material / Materiale / Material / Material / Материал	Plaster and glass / Gesso e vetro / Gips und Glas / Yeso y vidrio / Гипс и стекло	
Light source / Fonte di luce / Lichtquelle / Fuente de luz / Источник света	GX53 2 x 10W	
Type-approvals / Omologazioni / Zulassungen / Homologaciones / Разрешения		

T394 Patra - p. 254

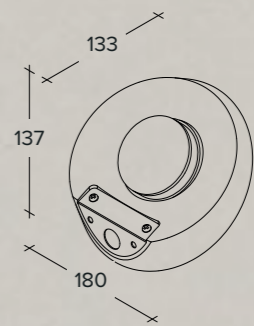

Plaster wall lamp for indirect lighting
(Modello depositato)

Designed by	_blank design studio	
Material / Materiale / Material / Material / Материал	Plaster / Gesso / Gips / Yeso / Гипсовый	
Light source / Fonte di luce / Lichtquelle / Fuente de luz / Источник света	GX53 1 x 10W	
Type-approvals / Omologazioni / Zulassungen / Homologaciones / Разрешения		

T389 Cicladi - p. 250

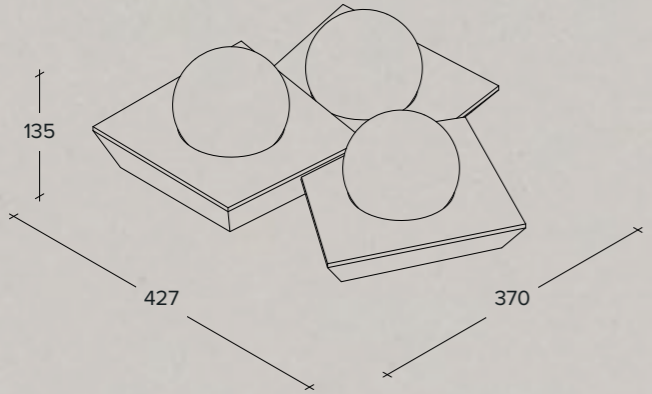

Plaster ceiling lamp with two round blown glass
(Modello depositato)

Designed by	_blank design studio	
Material / Materiale / Material / Material / Материал	Plaster and glass / Gesso e vetro / Gips und Glas / Yeso y vidrio / Гипс и стекло	
Light source / Fonte di luce / Lichtquelle / Fuente de luz / Источник света	GX53 3 x 10W	
Type-approvals / Omologazioni / Zulassungen / Homologaciones / Разрешения		

T395 Patra - p. 256

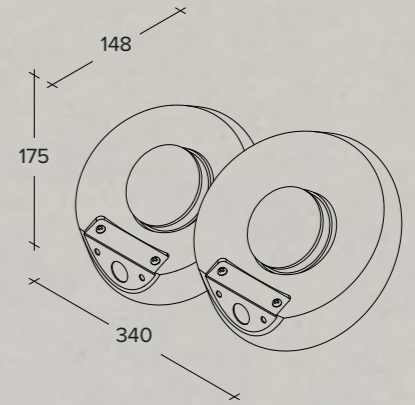



Plaster wall lamp for indirect lighting
(Modello depositato)

Designed by	_blank design studio	
Material / Materiale / Material / Material / Материал	Plaster / Gesso / Gips / Yeso / Гипсовый	
Light source / Fonte di luce / Lichtquelle / Fuente de luz / Источник света	GX53 2 x 10W	
Type-approvals / Omologazioni / Zulassungen / Homologaciones / Разрешения		

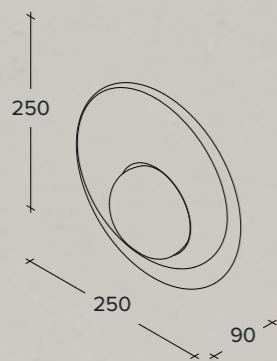
T399 Pitane - p. 260





Plaster ceiling/wall lamp with one round blown glass
(Modello depositato)

Designed by	_blank design studio	
Material / Materiale / Material / Material / Материал	Plaster and glass / Gesso e vetro / Gips und Glas / Yeso y vidrio / Гипс и стекло	
Light source / Fonte di luce / Lichtquelle / Fuente de luz / Источник света	GX53 1 x 10W	
Type-approvals / Omologazioni / Zulassungen / Homologaciones / Разрешения	  	

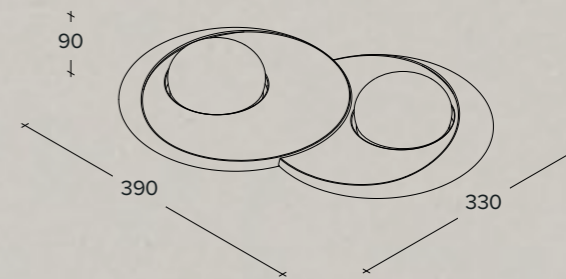
T401 Pitane - p. 262





Plaster ceiling/wall lamp with two round blown glass
(Modello depositato)

Designed by	_blank design studio	
Material / Materiale / Material / Material / Материал	Plaster and glass / Gesso e vetro / Gips und Glas / Yeso y vidrio / Гипс и стекло	
Light source / Fonte di luce / Lichtquelle / Fuente de luz / Источник света	GX53 2 x 10W	
Type-approvals / Omologazioni / Zulassungen / Homologaciones / Разрешения	  	

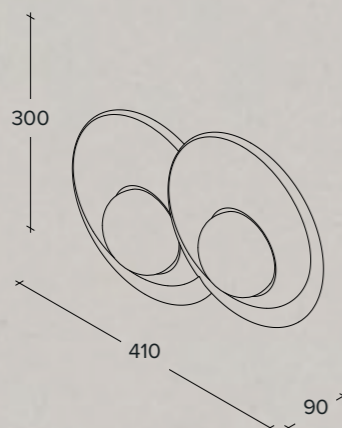
T400 Pitane - p. 261





Plaster ceiling/wall lamp with two round blown glass
(Modello depositato)

Designed by	_blank design studio	
Material / Materiale / Material / Material / Материал	Plaster and glass / Gesso e vetro / Gips und Glas / Yeso y vidrio / Гипс и стекло	
Light source / Fonte di luce / Lichtquelle / Fuente de luz / Источник света	GX53 2 x 10W	
Type-approvals / Omologazioni / Zulassungen / Homologaciones / Разрешения	  	

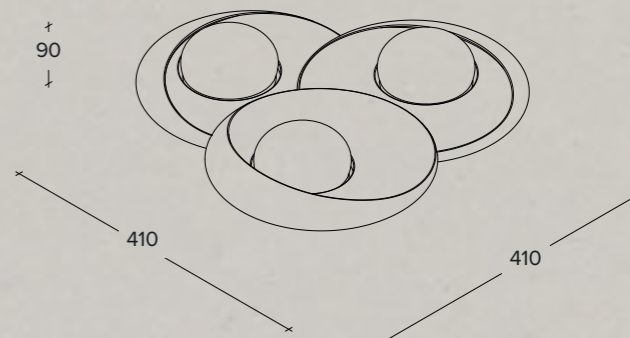
T402 Pitane - p. 263



Plaster ceiling/wall lamp with three round blown glass
(Modello depositato)

Designed by	_blank design studio	
Material / Materiale / Material / Material / Материал	Plaster and glass / Gesso e vetro / Gips und Glas / Yeso y vidrio / Гипс и стекло	
Light source / Fonte di luce / Lichtquelle / Fuente de luz / Источник света	GX53 3 x 10W	
Type-approvals / Omologazioni / Zulassungen / Homologaciones / Разрешения	  	

T339 Demetra - p. 267

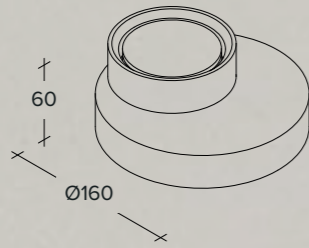

One-light plaster ceiling lamp
(Modello depositato)

Designed by _blank design studio

Material / Materiale / Material / Material / Материал **Plaster / Gesso / Gips / Yeso / штукатурка**

Light source / Fonte di luce / Lichtquelle / Fuente de luz / Источник света GX53
1 x 10W

Type-approvals / Omologazioni / Zulassungen / Homologaciones / Разрешения CE F ⊕ LED BULB OK

T359 Demetra - p. 269

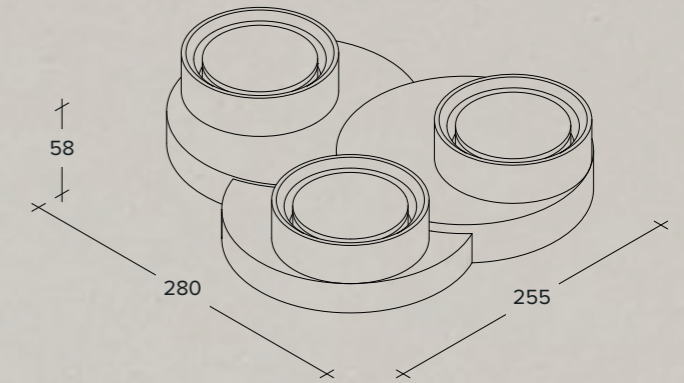

Three-lights plaster ceiling lamp
(Modello depositato)

Designed by _blank design studio

Material / Materiale / Material / Material / Материал **Plaster / Gesso / Gips / Yeso / штукатурка**

Light source / Fonte di luce / Lichtquelle / Fuente de luz / Источник света GX53
3 x 10W

Type-approvals / Omologazioni / Zulassungen / Homologaciones / Разрешения CE F ⊕ LED BULB OK

T358 Demetra - p. 268

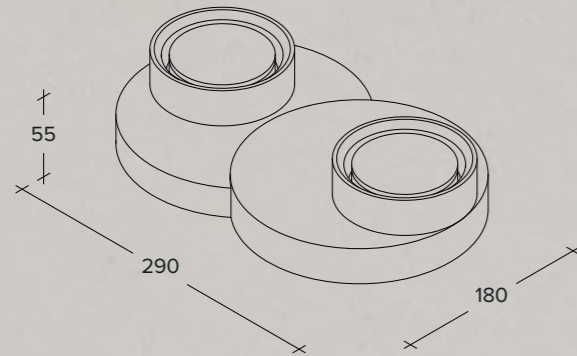

Two-lights plaster ceiling lamp
(Modello depositato)

Designed by _blank design studio

Material / Materiale / Material / Material / Материал **Plaster / Gesso / Gips / Yeso / штукатурка**

Light source / Fonte di luce / Lichtquelle / Fuente de luz / Источник света GX53
2 x 10W

Type-approvals / Omologazioni / Zulassungen / Homologaciones / Разрешения CE F ⊕ LED BULB OK

T360 Demetra - p. 271

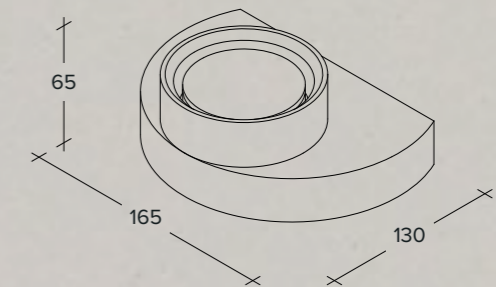

One-light plaster wall lamp
(Modello depositato)

Designed by _blank design studio

Material / Materiale / Material / Material / Материал **Plaster / Gesso / Gips / Yeso / штукатурка**



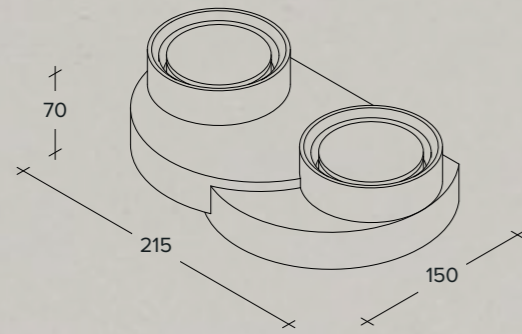

Light source / Fonte di luce / Lichtquelle / Fuente de luz / Источник света GX53
1 x 10W

Type-approvals / Omologazioni / Zulassungen / Homologaciones / Разрешения CE F ⊕ LED BULB OK

T361 Demetra - p. 272



Two-lights plaster wall lamp
(Modello depositato)





Designed by	_blank design studio	
Material / Materiale / Material / Material / Материал	Plaster / Gesso / Gips / Yeso / штукатурка	
Light source / Fonte di luce / Lichtquelle / Fuente de luz / Источник света	GX53 2 x 10W	
Type-approvals / Omologazioni / Zulassungen / Homologaciones / Разрешения	   	

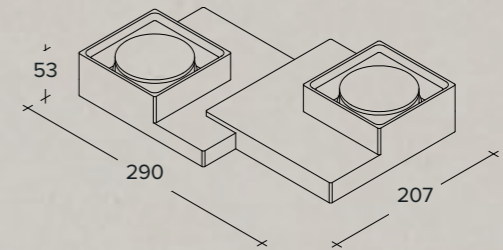

T377 Sibari - p. 276



Two-lights plaster ceiling lamp
(Modello depositato)



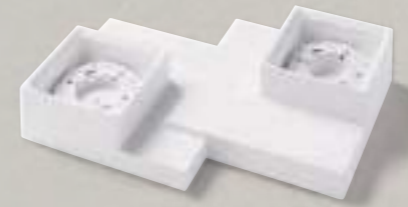

Designed by	_blank design studio	
Material / Materiale / Material / Material / Материал	Plaster / Gesso / Gips / Yeso / штукатурка	
Light source / Fonte di luce / Lichtquelle / Fuente de luz / Источник света	GX53 2 x 10W	
Type-approvals / Omologazioni / Zulassungen / Homologaciones / Разрешения	   	

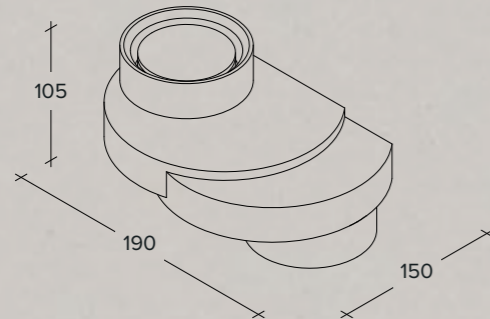

T362 Demetra - p. 273



Two-lights double emission plaster wall lamp
(Modello depositato)





Designed by	_blank design studio	
Material / Materiale / Material / Material / Материал	Plaster / Gesso / Gips / Yeso / штукатурка	
Light source / Fonte di luce / Lichtquelle / Fuente de luz / Источник света	GX53 2 x 10W	
Type-approvals / Omologazioni / Zulassungen / Homologaciones / Разрешения	   	

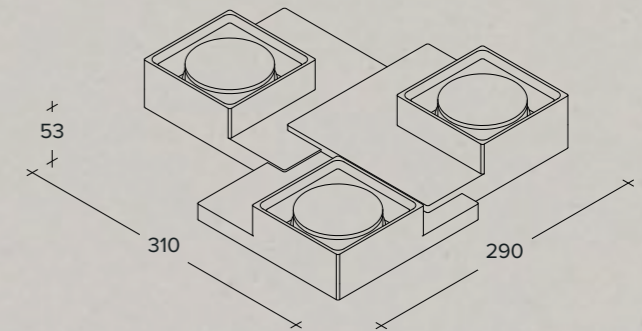

T378 Sibari - p. 277



Three-lights plaster ceiling lamp
(Modello depositato)

Designed by	_blank design studio	
Material / Materiale / Material / Material / Материал	Plaster / Gesso / Gips / Yeso / штукатурка	
Light source / Fonte di luce / Lichtquelle / Fuente de luz / Источник света	GX53 3 x 10W	
Type-approvals / Omologazioni / Zulassungen / Homologaciones / Разрешения	   	



T379 Sibari - p. 278

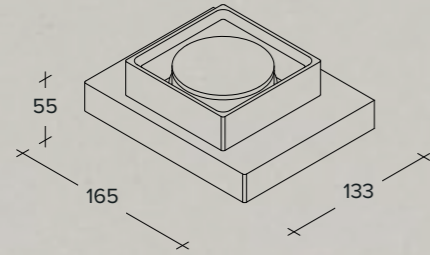

One-light plaster wall lamp

Designed by **_blank design studio**

Material / Materiale / Material / Material / Материал **Plaster / Gesso / Gips / Yeso / штукатурка**

Light source / Fonte di luce / Lichtquelle / Fuente de luz / Источник света **GX53 1 x 10W**

Type-approvals / Omologazioni / Zulassungen / Homologaciones / Разрешения **CE F ⊕ LED BULB OK**



T371 Anchise - p. 282

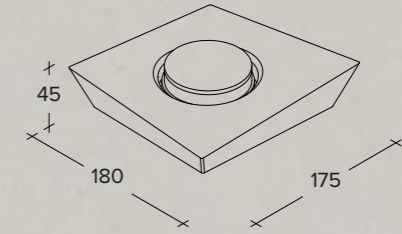

One light plaster ceiling lamp with irregular geometry (Modello depositato)

Designed by **_blank design studio**

Material / Materiale / Material / Material / Материал **Plaster / Gesso / Gips / Yeso / штукатурка**

Light source / Fonte di luce / Lichtquelle / Fuente de luz / Источник света **GX53 1 x 10W**

Type-approvals / Omologazioni / Zulassungen / Homologaciones / Разрешения **CE F ⊕ LED BULB OK**



T380 Sibari - p. 279

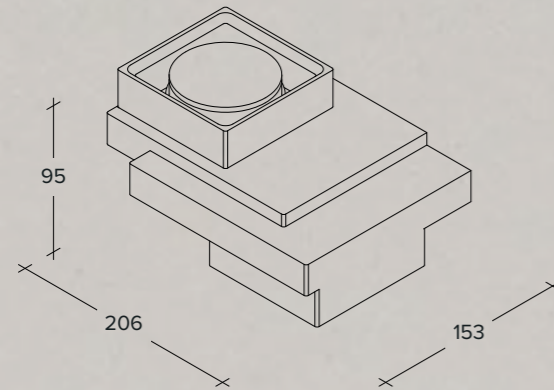

Two-lights double emission plaster wall lamp

Designed by **_blank design studio**

Material / Materiale / Material / Material / Материал **Plaster / Gesso / Gips / Yeso / штукатурка**

Light source / Fonte di luce / Lichtquelle / Fuente de luz / Источник света **GX53 2 x 10W**

Type-approvals / Omologazioni / Zulassungen / Homologaciones / Разрешения **CE F ⊕ LED BULB OK**

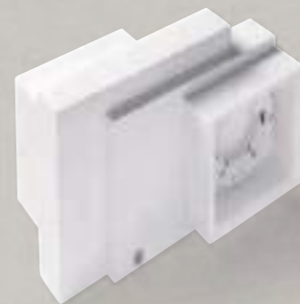

T372 Anchise - p. 283

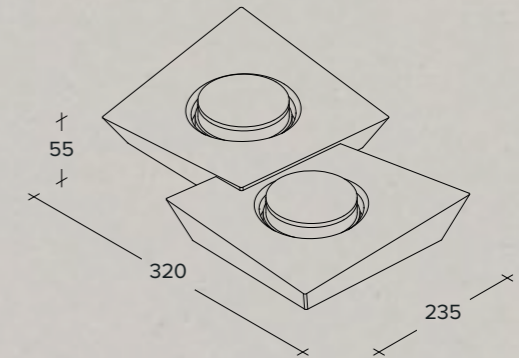

Two light plaster ceiling lamp with irregular geometry (Modello depositato)

Designed by **_blank design studio**

Material / Materiale / Material / Material / Материал **Plaster / Gesso / Gips / Yeso / штукатурка**

Light source / Fonte di luce / Lichtquelle / Fuente de luz / Источник света **GX53 2 x 10W**

Type-approvals / Omologazioni / Zulassungen / Homologaciones / Разрешения **CE F ⊕ LED BULB OK**



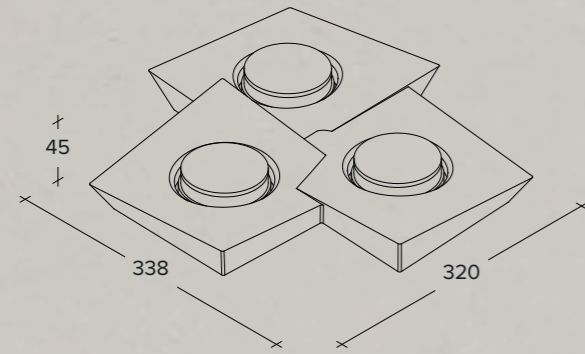

T373 Anchise - p. 284



Three light plaster ceiling lamp with irregular geometry
(Modello depositato)

Designed by _blank design studio

Material / Materiale / Material / Material / Материал **Plaster / Gesso / Gips / Yeso / штукатурка**

Light source / Fonte di luce / Lichtquelle / Fuente de luz / Источник света GX53
3 x 10W

Type-approvals / Omologazioni / Zulassungen / Homologaciones / Разрешения CE F ⊕ LED BULB OK



T375 Anchise - p. 287



Up/Down dual lighting plaster wall lamp with irregular geometry
(Modello depositato)

Designed by _blank design studio

Material / Materiale / Material / Material / Материал **Plaster / Gesso / Gips / Yeso / штукатурка**

Light source / Fonte di luce / Lichtquelle / Fuente de luz / Источник света GX53
2 x 10W

Type-approvals / Omologazioni / Zulassungen / Homologaciones / Разрешения CE F ⊕ LED BULB OK

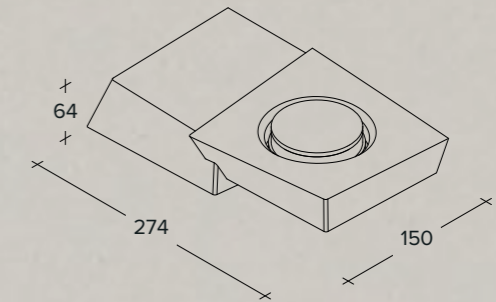

T374 Anchise - p. 286

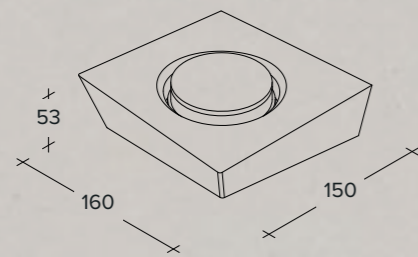

One-light plaster wall lamp with irregular geometry
(Modello depositato)

Designed by _blank design studio

Material / Materiale / Material / Material / Материал **Plaster / Gesso / Gips / Yeso / штукатурка**

Light source / Fonte di luce / Lichtquelle / Fuente de luz / Источник света GX53
1 x 10W

Type-approvals / Omologazioni / Zulassungen / Homologaciones / Разрешения CE F ⊕ LED BULB OK



T262 Chio - p. 290



Three-lights plaster ceiling lamp
(Modello depositato)

Designed by Acero design studio

Material / Materiale / Material / Material / Материал **Plaster / Gesso / Gips / Yeso / штукатурка**

Light source / Fonte di luce / Lichtquelle / Fuente de luz / Источник света GX53
3 x 10W

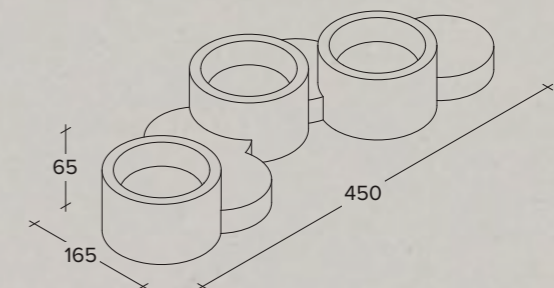

Type-approvals / Omologazioni / Zulassungen / Homologaciones / Разрешения CE F ⊕ LED BULB OK

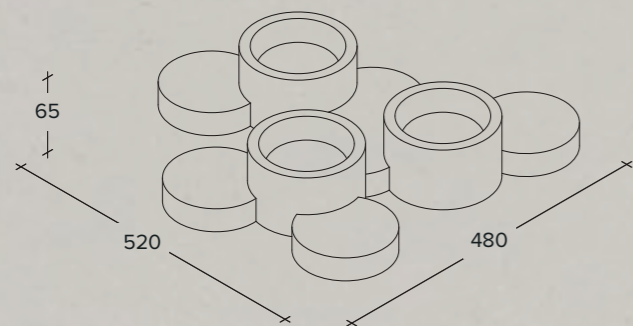

T263 Chio - p. 291





Three-lights plaster ceiling lamp
(Modello depositato)

Designed by	Acero design studio
Material / Materiale / Material / Material / Материал	Plaster / Gesso / Gips / Yeso / штукатурка
Light source / Fonte di luce / Lichtquelle / Fuente de luz / Источник света	GX53 3 x 10W
Type-approvals / Omologazioni / Zulassungen / Homologaciones / Разрешения	  

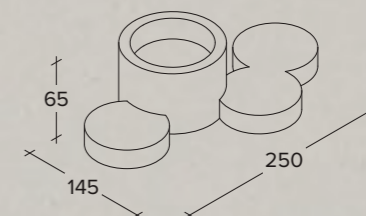
T274 Chio - p. 294





One-light plaster ceiling lamp
(Modello depositato)

Designed by	Acero design studio
Material / Materiale / Material / Material / Материал	Plaster / Gesso / Gips / Yeso / штукатурка
Light source / Fonte di luce / Lichtquelle / Fuente de luz / Источник света	GX53 1 x 10W
Type-approvals / Omologazioni / Zulassungen / Homologaciones / Разрешения	  

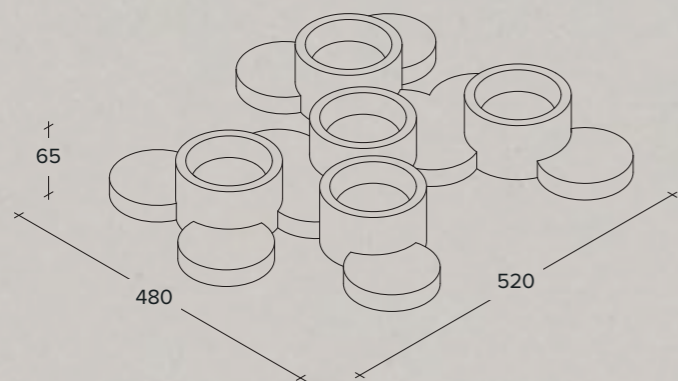
T264 Chio - p. 292





Five-lights plaster ceiling lamp
(Modello depositato)

Designed by	Acero design studio
Material / Materiale / Material / Material / Материал	Plaster / Gesso / Gips / Yeso / штукатурка
Light source / Fonte di luce / Lichtquelle / Fuente de luz / Источник света	GX53 5 x 10W
Type-approvals / Omologazioni / Zulassungen / Homologaciones / Разрешения	  

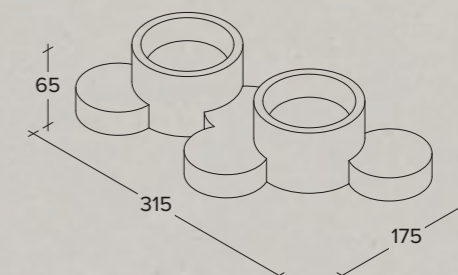
T278 Chio - p. 295





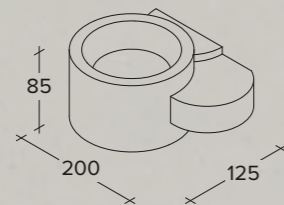

Two-lights plaster ceiling lamp
(Modello depositato)

Designed by	Acero design studio
Material / Materiale / Material / Material / Материал	Plaster / Gesso / Gips / Yeso / штукатурка
Light source / Fonte di luce / Lichtquelle / Fuente de luz / Источник света	GX53 2 x 10W
Type-approvals / Omologazioni / Zulassungen / Homologaciones / Разрешения	  

T319 Chio - p. 296





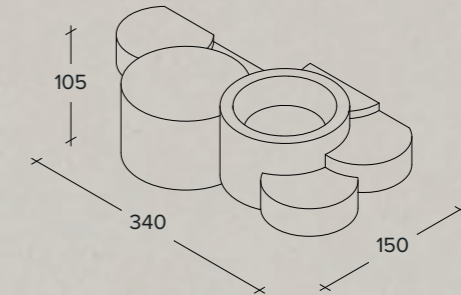

One-light plaster wall lamp
(Modello depositato)

Designed by	Acero design studio
Material / Materiale / Material / Material / Материал	Plaster / Gesso / Gips / Yeso / штукатурка
Light source / Fonte di luce / Lichtquelle / Fuente de luz / Источник света	GX53 1 x 10W
Type-approvals / Omologazioni / Zulassungen / Homologaciones / Разрешения	   

T321 Chio - p. 298



Up/down two-lights plaster wall lamp
(Modello depositato)





Designed by	Acero design studio
Material / Materiale / Material / Material / Материал	Plaster / Gesso / Gips / Yeso / штукатурка
Light source / Fonte di luce / Lichtquelle / Fuente de luz / Источник света	GX53 2 x 10W
Type-approvals / Omologazioni / Zulassungen / Homologaciones / Разрешения	   

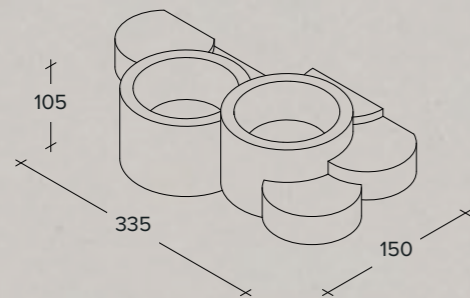

T320 Chio - p. 297





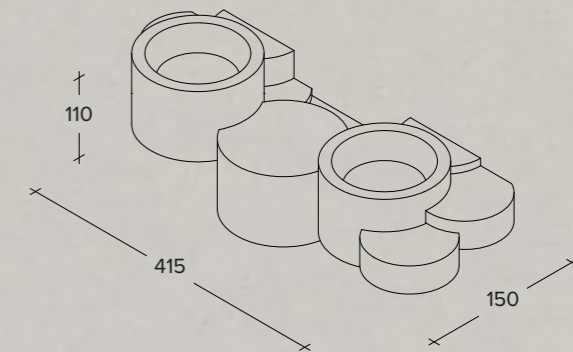

Two-lights plaster wall lamp
(Modello depositato)

Designed by	Acero design studio
Material / Materiale / Material / Material / Материал	Plaster / Gesso / Gips / Yeso / штукатурка
Light source / Fonte di luce / Lichtquelle / Fuente de luz / Источник света	GX53 2 x 10W
Type-approvals / Omologazioni / Zulassungen / Homologaciones / Разрешения	   

T322 Chio - p. 299



Up/down three-lights plaster wall lamp
(Modello depositato)

Designed by	Acero design studio
Material / Materiale / Material / Material / Материал	Plaster / Gesso / Gips / Yeso / штукатурка
Light source / Fonte di luce / Lichtquelle / Fuente de luz / Источник света	GX53 3 x 10W
Type-approvals / Omologazioni / Zulassungen / Homologaciones / Разрешения	   



T291 Side - p. 302

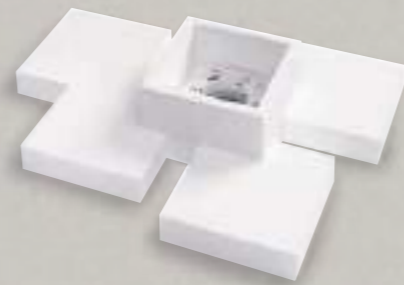
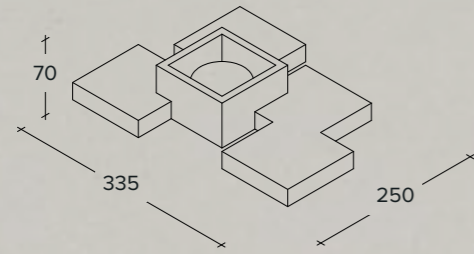

One-light plaster ceiling lamp
(Modello depositato)

Designed by Acero design studio

Material / Materiale / Material / Material / Материал Plaster / Gesso / Gips / Yeso / Гипсовый

Light source / Fonte di luce / Lichtquelle / Fuente de luz / Источник света GX53
1 x 10W

Type-approvals / Omologazioni / Zulassungen / Homologaciones / Разрешения CE F ⊕ LED BULB OK

T293 Side - p. 304

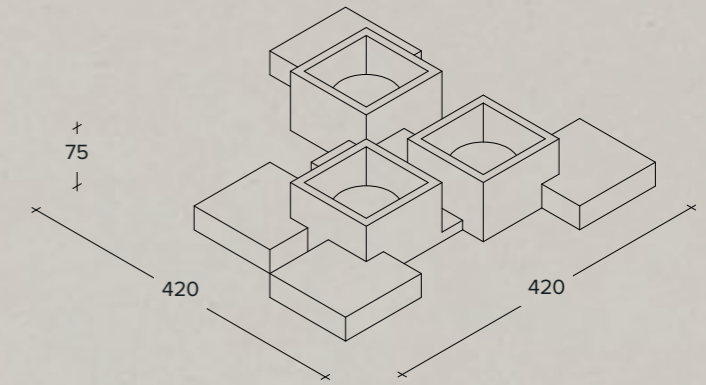

Three-lights plaster ceiling lamp
(Modello depositato)

Designed by Acero design studio

Material / Materiale / Material / Material / Материал Plaster / Gesso / Gips / Yeso / Гипсовый

Light source / Fonte di luce / Lichtquelle / Fuente de luz / Источник света GX53
3 x 10W

Type-approvals / Omologazioni / Zulassungen / Homologaciones / Разрешения CE F ⊕ LED BULB OK

T292 Side - p. 305

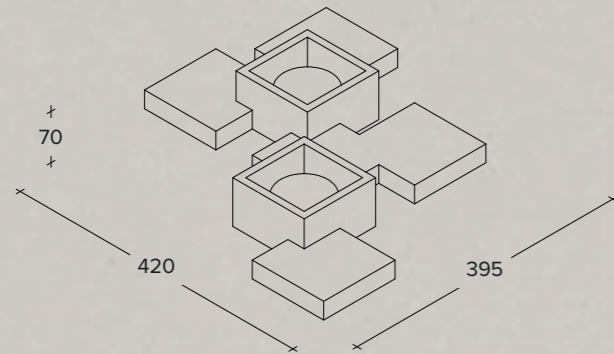

Two-lights plaster ceiling lamp
(Modello depositato)

Designed by Acero design studio

Material / Materiale / Material / Material / Материал Plaster / Gesso / Gips / Yeso / Гипсовый

Light source / Fonte di luce / Lichtquelle / Fuente de luz / Источник света GX53
2 x 10W

Type-approvals / Omologazioni / Zulassungen / Homologaciones / Разрешения CE F ⊕ LED BULB OK

T326 Side - p. 306

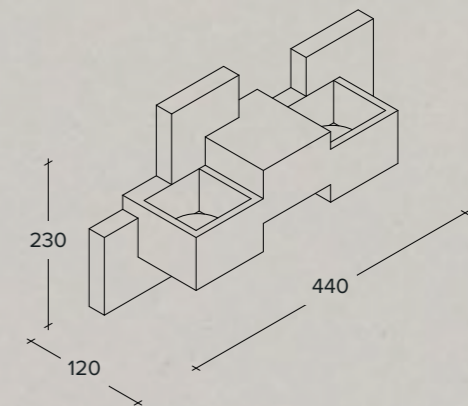
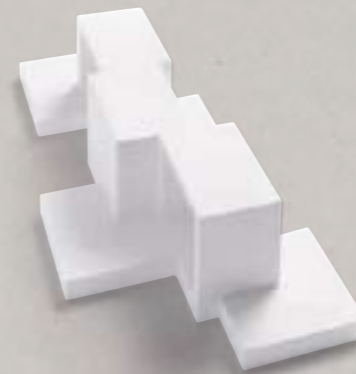
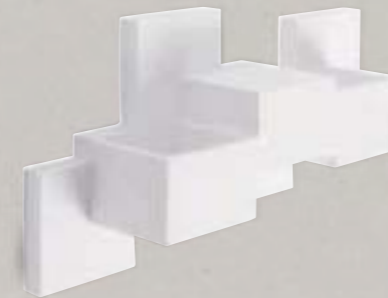

Three-lights Up/down plaster wall lamp
(Modello depositato)

Designed by Acero design studio

Material / Materiale / Material / Material / Материал Plaster / Gesso / Gips / Yeso / Гипсовый

Light source / Fonte di luce / Lichtquelle / Fuente de luz / Источник света GX53
3 x 10W

Type-approvals / Omologazioni / Zulassungen / Homologaciones / Разрешения CE F ⊕ LED BULB OK

T367 Side Small - p. 310

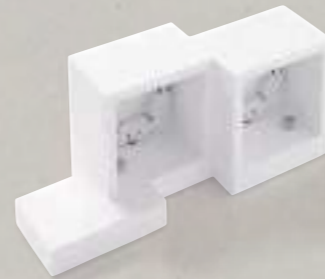
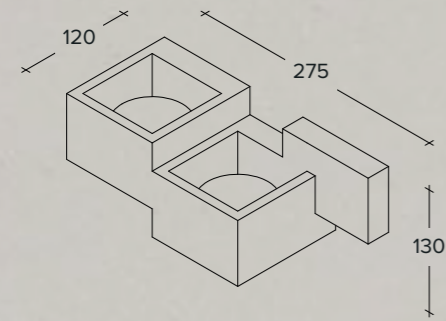



Two-lights plaster wall lamp

Designed by **Acero design studio**

Material / Materiale / Material / Material / Материал **Plaster / Gesso / Gips / Yeso / Гипсовый**

Light source / Fonte di luce / Lichtquelle / Fuente de luz / Источник света **GX53
2 x 10W**

Type-approvals / Omologazioni / Zulassungen / Homologaciones / Разрешения **CE**  

T369 Side Small - p. 312

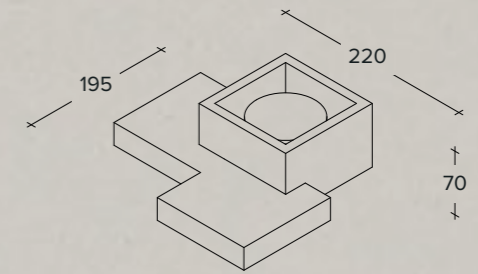



One-light plaster ceiling lamp

Designed by **Acero design studio**

Material / Materiale / Material / Material / Материал **Plaster / Gesso / Gips / Yeso / Гипсовый**

Light source / Fonte di luce / Lichtquelle / Fuente de luz / Источник света **GX53
1 x 10W**

Type-approvals / Omologazioni / Zulassungen / Homologaciones / Разрешения **CE**  

T368 Side Small - p. 311

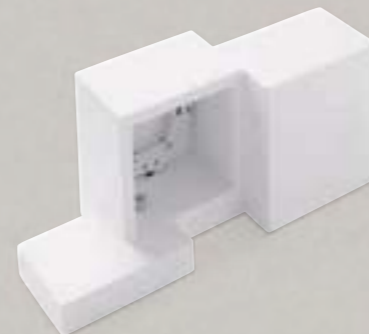
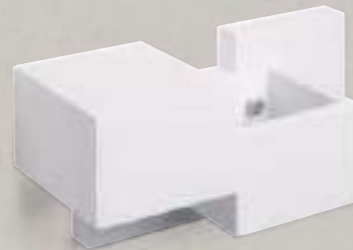
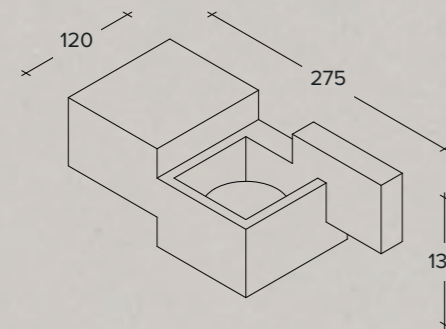



Up/Down dual lighting plaster wall lamp

Designed by **Acero design studio**

Material / Materiale / Material / Material / Материал **Plaster / Gesso / Gips / Yeso / Гипсовый**

Light source / Fonte di luce / Lichtquelle / Fuente de luz / Источник света **GX53
2 x 10W**

Type-approvals / Omologazioni / Zulassungen / Homologaciones / Разрешения **CE**  

T193 Heraea - p. 316

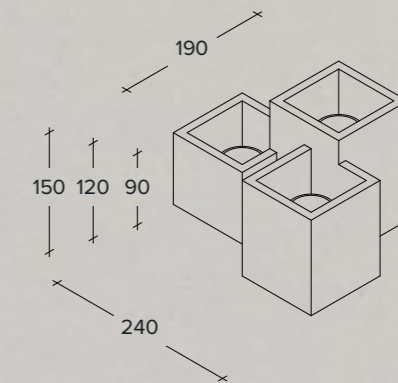



Three-lights plaster ceiling lamp

Designed by **Acero design studio**

Material / Materiale / Material / Material / Материал **Plaster / Gesso / Gips / Yeso / Гипсовый**

Light source / Fonte di luce / Lichtquelle / Fuente de luz / Источник света **GU10
3 x 40W**

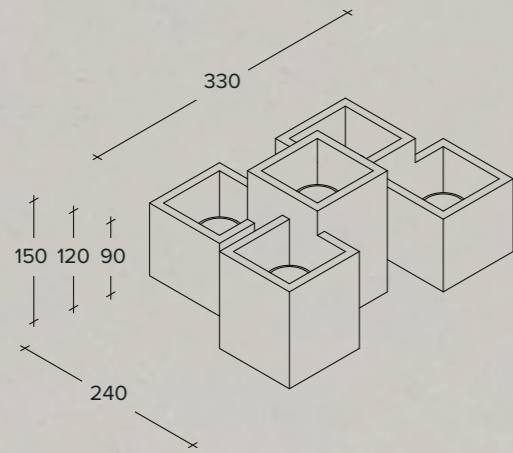

Type-approvals / Omologazioni / Zulassungen / Homologaciones / Разрешения **CE**  



T194 Heraea - p. 317





Five-lights plaster ceiling lamp

Designed by	Acero design studio	
Material / Materiale / Material / Material / Материал	Plaster / Gesso / Gips / Yeso / Гипсовый	
Light source / Fonte di luce / Lichtquelle / Fuente de luz / Источник света	GU10 5 x 40W	
Type-approvals / Omologazioni / Zulassungen / Homologaciones / Разрешения	  	

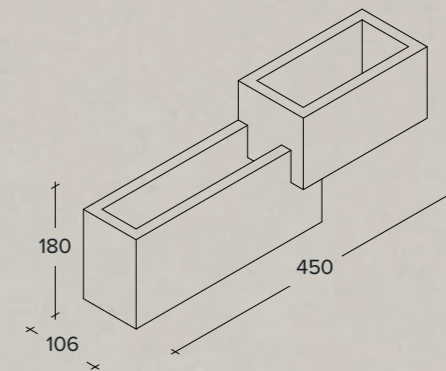
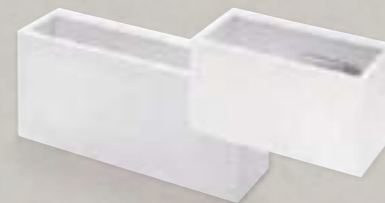
T269 Paro - p. 322





Three-lights, double emission plaster wall lamp
(Modello depositato)

Designed by	Acero design studio	
Material / Materiale / Material / Material / Материал	Plaster and glass / Gesso e vetro / Gips und Glas / Yeso y vidrio / Гипс и стекло	
Light source / Fonte di luce / Lichtquelle / Fuente de luz / Источник света	G9 3 x 40W	
Type-approvals / Omologazioni / Zulassungen / Homologaciones / Разрешения	  	

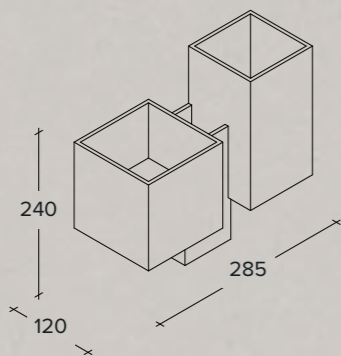
T205 Heraea - p. 318





Up/down four lights plaster wall lamp

Designed by	Acero design studio	
Material / Materiale / Material / Material / Материал	Plaster / Gesso / Gips / Yeso / Гипсовый	
Light source / Fonte di luce / Lichtquelle / Fuente de luz / Источник света	G9 4 x 40W	
Type-approvals / Omologazioni / Zulassungen / Homologaciones / Разрешения	  	

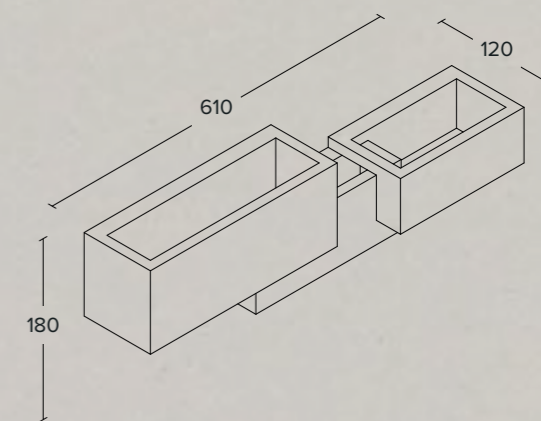
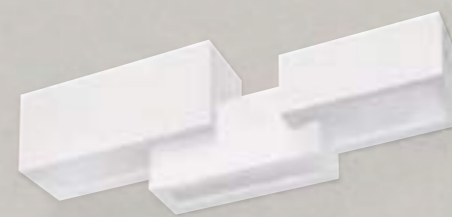
T270 Paro - p. 323



Five-lights, double emission plaster wall lamp
(Modello depositato)

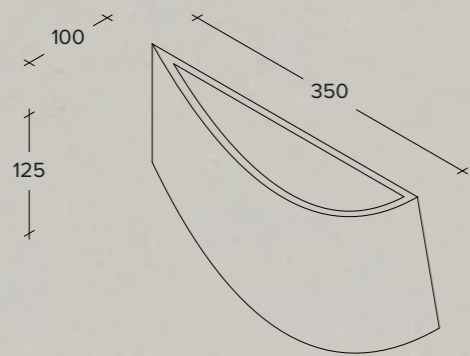

Designed by	Acero design studio	
Material / Materiale / Material / Material / Материал	Plaster and glass / Gesso e vetro / Gips und Glas / Yeso y vidrio / Гипс и стекло	
Light source / Fonte di luce / Lichtquelle / Fuente de luz / Источник света	G9 5 x 40W	
Type-approvals / Omologazioni / Zulassungen / Homologaciones / Разрешения	  	



T223 Delfi - p. 324



Two-lights plaster wall lamp



Designed by	Luca Artoli
Material / Materiale / Material / Material / Материал	Plaster and glass / Gesso e vetro / Gips und Glas / Yeso y vidrio / Гипс и стекло
Light source / Fonte di luce / Lichtquelle / Fuente de luz / Источник света	G9 2 x 40W
Type-approvals / Omologazioni / Zulassungen / Homologaciones / Разрешения	  

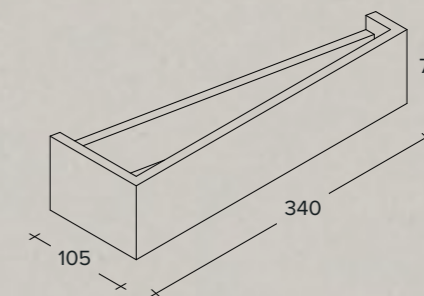

T174.11 Teos - p. 331



Plaster wall light, dual emission



Designed by	Acero design studio
Material / Materiale / Material / Material / Материал	Plaster and glass / Gesso e vetro / Gips und Glas / Yeso y vidrio / Гипс и стекло
Light source / Fonte di luce / Lichtquelle / Fuente de luz / Источник света	G9 2 x 40W
Type-approvals / Omologazioni / Zulassungen / Homologaciones / Разрешения	  

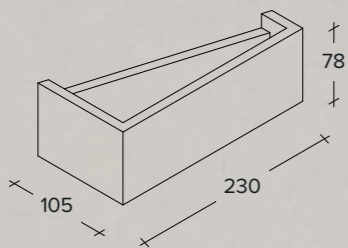

T174.10 Teos - p. 330



Plaster wall light, dual emission

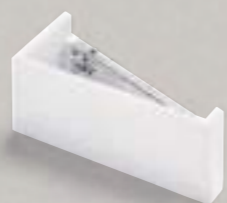

Designed by	Acero design studio
Material / Materiale / Material / Material / Материал	Plaster and glass / Gesso e vetro / Gips und Glas / Yeso y vidrio / Гипс и стекло
Light source / Fonte di luce / Lichtquelle / Fuente de luz / Источник света	G9 2 x 40W
Type-approvals / Omologazioni / Zulassungen / Homologaciones / Разрешения	  

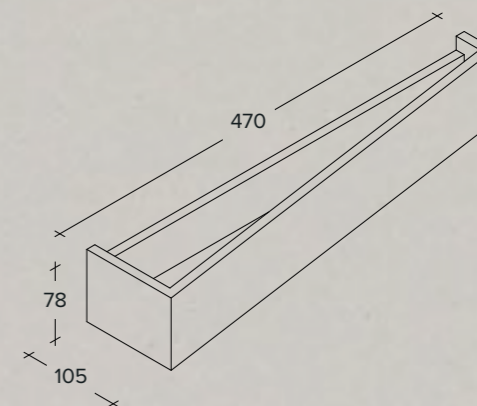

T174.12 Teos - p. 332



Plaster wall light, dual emission

Designed by	Acero design studio
Material / Materiale / Material / Material / Материал	Plaster and glass / Gesso e vetro / Gips und Glas / Yeso y vidrio / Гипс и стекло
Light source / Fonte di luce / Lichtquelle / Fuente de luz / Источник света	G9 3 x 40W
Type-approvals / Omologazioni / Zulassungen / Homologaciones / Разрешения	  



T200 Pellene - p. 336

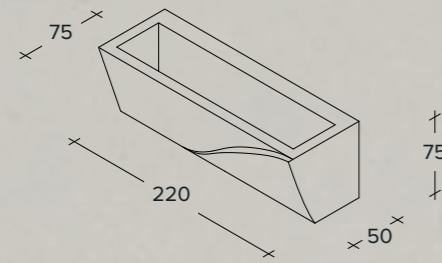

One-light dual emission plaster wall lamp with frontal beamline

Designed by	Luca Artioli
Material / Materiale / Material / Material / Материал	Plaster / Gesso / Gips / Yeso / Гипсовый
Light source / Fonte di luce / Lichtquelle / Fuente de luz / Источник света	G9 1 x 40W
Type-approvals / Omologazioni / Zulassungen / Homologaciones / Разрешения	

T208 Hermione - p. 340

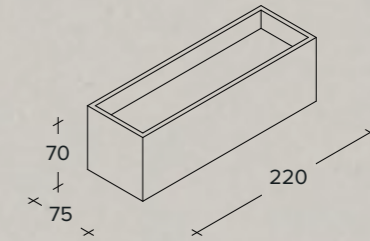

Plaster dual emission wall light

Designed by	Acero design studio
Material / Materiale / Material / Material / Материал	Plaster and glass / Gesso e vetro / Gips und Glas / Yeso y vidrio / Гипс и стекло
Light source / Fonte di luce / Lichtquelle / Fuente de luz / Источник света	G9 1 x 40W
Type-approvals / Omologazioni / Zulassungen / Homologaciones / Разрешения	

T201 Pellene - p. 337

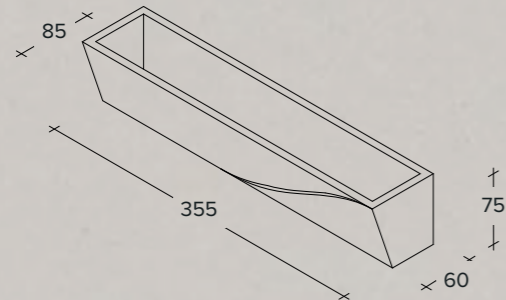

Two-lights dual emission plaster wall lamp with frontal beamline

Designed by	Luca Artioli
Material / Materiale / Material / Material / Материал	Plaster / Gesso / Gips / Yeso / Гипсовый
Light source / Fonte di luce / Lichtquelle / Fuente de luz / Источник света	G9 2 x 40W
Type-approvals / Omologazioni / Zulassungen / Homologaciones / Разрешения	

T209 Hermione - p. 341

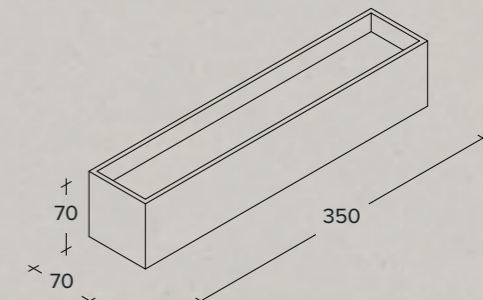



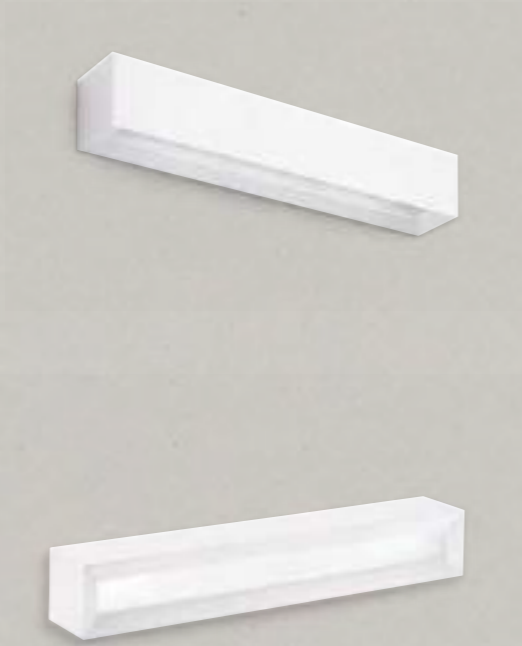
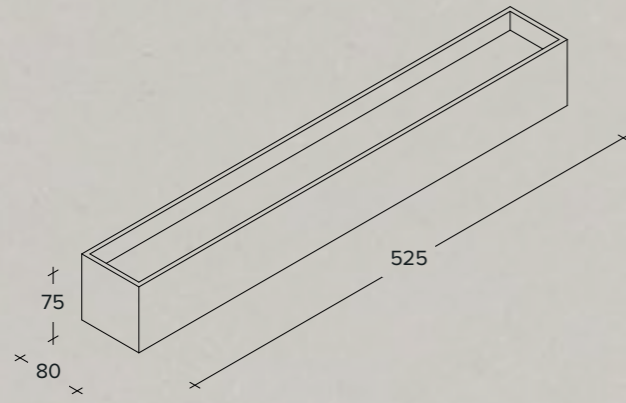

Plaster dual emission wall light

Designed by	Acero design studio
Material / Materiale / Material / Material / Материал	Plaster and glass / Gesso e vetro / Gips und Glas / Yeso y vidrio / Гипс и стекло
Light source / Fonte di luce / Lichtquelle / Fuente de luz / Источник света	G9 2 x 40W
Type-approvals / Omologazioni / Zulassungen / Homologaciones / Разрешения	

T210 Hermione - p. 342



Plaster dual emission wall light

Designed by	Acero design studio
Material / Materiale / Material / Material / Материал	Plaster and glass / Gesso e vetro / Gips und Glas / Yeso y vidrio / Гипс и стекло
Light source / Fonte di luce / Lichtquelle / Fuente de luz / Источник света	G9 3 x 40W
Type-approvals / Omologazioni / Zulassungen / Homologaciones / Разрешения	   

Pricelist by code

Listino prezzi per codice
Preisliste nach typ
Lista de precios por tipo
Прайс-лист по коду

Pricelist by code

Listino prezzi per codice
Preisliste nach code
Lista de precios por código
Прайс-лист по коду

				Including VAT IVA inclusa Inklusive MWST IVA incluido НДС включен	Excluding VAT Senza IVA Ohne MWST IVA excluido Без НДС
T04.GU10	ATTICA Incasso 1 Luce	pag. 150	21,00 €	17,21 €	
T28.GU10	ATTICA GLASS Incasso 1 Luce	pag. 150	21,00 €	17,21 €	
T73.50W.24.SNP	ALIMENTATORI 50W SNAPPY	pag. 355	58,00 €	47,54 €	
T73.100W.24.SNP	ALIMENTATORI 100W SNAPPY	pag. 355	108,00 €	88,52 €	
T73.150W.24.SNP	ALIMENTATORI 150W SNAPPY	pag. 355	102,00 €	83,61 €	
T73.200W.24.SNP	ALIMENTATORI 200W SNAPPY	pag. 355	163,00 €	133,61 €	
T73.320W.24.SNP	ALIMENTATORI 320W SNAPPY	pag. 355	237,00 €	194,26 €	
T73.40W.24.DIM	ALIMENTATORI 40W DIMMERABILE	pag. 355	97,00 €	79,51 €	
T73.100W.24.DIM	ALIMENTATORI 100W DIMMERABILE	pag. 355	146,00 €	119,67 €	
T73.150W.24.DIM	ALIMENTATORI 150W DIMMERABILE	pag. 355	153,00 €	125,41 €	
T73.240W.24.DIM	ALIMENTATORI 240W DIMMERABILE	pag. 355	192,00 €	157,38 €	
T73.320W.24.DIM	ALIMENTATORI 320W DIMMERABILE	pag. 355	261,00 €	213,93 €	
T133. TAGLIO	TAGLIO	pag. 348	20,00 €	16,39 €	
T133.W.50.OPAL	EMATHIA INCASSO Estruso Alluminio 50 cm Opalino	pag. 38	46,50 €	38,11 €	
T133.W.50.SAT	EMATHIA INCASSO Estruso Alluminio 50 cm Satinato	pag. 38	46,50 €	38,11 €	
T133.W.100.OPAL	EMATHIA INCASSO Estruso Alluminio 100 cm Opalino	pag. 38	93,00 €	76,23 €	
T133.W.100.SAT	EMATHIA INCASSO Estruso Alluminio 100 cm Satinato	pag. 38	93,00 €	76,23 €	
T133.W.150.OPAL	EMATHIA INCASSO Estruso Alluminio 150 cm Opalino	pag. 38	139,50 €	114,34 €	
T133.W.150.SAT	EMATHIA INCASSO Estruso Alluminio 150 cm Satinato	pag. 38	139,50 €	114,34 €	
T133.W.200.OPAL	EMATHIA INCASSO Estruso Alluminio 200 cm Opalino	pag. 38	186,00 €	152,46 €	
T133.W.200.SAT	EMATHIA INCASSO Estruso Alluminio 200 cm Satinato	pag. 38	186,00 €	152,46 €	
T133.AL.50.OPAL	EMATHIA INCASSO Estruso Bianco 50 cm Opalino	pag. 38	46,50 €	38,11 €	
T133.AL.50.SAT	EMATHIA INCASSO Estruso Bianco 50 cm Satinato	pag. 38	46,50 €	38,11 €	
T133.AL.100.OPAL	EMATHIA INCASSO Estruso Bianco 100 cm Opalino	pag. 38	93,00 €	76,23 €	
T133.AL.100.SAT	EMATHIA INCASSO Estruso Bianco 100cm Satinato	pag. 38	93,00 €	76,23 €	
T133.AL.150.OPAL	EMATHIA INCASSO Estruso Bianco 150 cm Opalino	pag. 38	139,50 €	114,34 €	
T133.AL.150.SAT	EMATHIA INCASSO Estruso Bianco 150 cm Satinato	pag. 38	139,50 €	114,34 €	

				Including VAT IVA inclusa Inklusive MWST IVA incluido НДС включен	Excluding VAT Senza IVA Ohne MWST IVA excluido Без НДС
T133.AL.200.OPAL	EMATHIA INCASSO Estruso Bianco 200 cm Opalino	pag. 38	186,00 €	152,46 €	
T133.AL.200.SAT	EMATHIA INCASSO Estruso Bianco 200 cm Satinato	pag. 38	186,00 €	152,46 €	
T139.W.50.OPAL	EUBEA INCASSO Estruso Bianco 50 cm Opalino	pag. 43	36,00 €	29,51 €	
T139.W.50.SAT	EUBEA INCASSO Estruso Bianco 50 cm Satinato	pag. 43	36,00 €	29,51 €	
T139.W.100.OPAL	EUBEA INCASSO Estruso Bianco 100 cm Opalino	pag. 43	71,00 €	58,20 €	
T139.W.100.SAT	EUBEA INCASSO Estruso Bianco 100 cm Satinato	pag. 43	71,00 €	58,20 €	
T139.W.150.OPAL	EUBEA INCASSO Estruso Bianco 150 cm Opalino	pag. 43	106,00 €	86,89 €	
T139.W.150.SAT	EUBEA INCASSO Estruso Bianco 150 cm Satinato	pag. 43	106,00 €	86,89 €	
T139.W.200.OPAL	EUBEA INCASSO Estruso Bianco 200 cm Opalino	pag. 43	141,00 €	115,57 €	
T139.W.200.SAT	EUBEA INCASSO Estruso Bianco 200 cm Satinato	pag. 43	141,00 €	115,57 €	
T139.AL.50.OPAL	EUBEA INCASSO Estruso Alluminio 50 cm Opalino	pag. 43	36,00 €	29,51 €	
T139.AL.50.SAT	EUBEA INCASSO Estruso Alluminio 50 cm Satinato	pag. 43	36,00 €	29,51 €	
T139.AL.100.OPAL	EUBEA INCASSO Estruso Alluminio 100 cm Opalino	pag. 43	71,00 €	58,20 €	
T139.AL.100.SAT	EUBEA INCASSO Estruso Alluminio 100 cm Satinato	pag. 43	71,00 €	58,20 €	
T139.AL.150.OPAL	EUBEA INCASSO Estruso Alluminio 150 cm Opalino	pag. 43	106,00 €	86,89 €	
T139.AL.150.SAT	EUBEA INCASSO Estruso Alluminio 150 cm Satinato	pag. 43	106,00 €	86,89 €	
T139.AL.200.OPAL	EUBEA INCASSO Estruso Alluminio 200 cm Opalino	pag. 43	141,00 €	115,57 €	
T139.AL.200.SAT	EUBEA INCASSO Estruso Alluminio 200 cm Satinato	pag. 43	141,00 €	115,57 €	
T145.W.50.OPAL	EUBEA ESTERNO Estruso Bianco 50 cm Opalino	pag. 43	33,00 €	27,05 €	
T145.W.50.SAT	EUBEA ESTERNO Estruso Bianco 50 cm Satinato	pag. 43	33,00 €	27,05 €	
T145.W.100.OPAL	EUBEA ESTERNO Estruso Bianco 100 cm Opalino	pag. 43	64,50 €	52,87 €	
T145.W.100.SAT	EUBEA ESTERNO Estruso Bianco 100 cm Satinato	pag. 43	64,50 €	52,87 €	
T145.W.150.OPAL	EUBEA ESTERNO Estruso Bianco 150 cm Opalino	pag. 43	97,00 €	79,51 €	
T145.W.150.SAT	EUBEA ESTERNO Estruso Bianco 150 cm Satinato	pag. 43	97,00 €	79,51 €	
T145.W.200.OPAL	EUBEA ESTERNO Estruso Bianco 200 cm Opalino	pag. 43	129,00 €	105,74 €	
T145.W.200.SAT	EUBEA ESTERNO Estruso Bianco 200 cm Satinato	pag. 43	129,00 €	105,74 €	
T145.AL.50.OPAL	EUBEA ESTERNO Estruso Alluminio 50 cm Opalino	pag. 43	33,00 €	27,05 €	

Pricelist by code

Listino prezzi per codice
Preisliste nach code
Lista de precios por código
Прайс-лист по коду

			Including VAT IVA inclusa Inklusive MWST IVA incluido НДС включен	Excluding VAT Senza IVA Ohne MWST IVA excluido Без НДС
T145.AL.50.SAT	EUBEA ESTERNO Estruso Alluminio 50 cm Satinato	pag. 43	33,00 €	27,05 €
T145.AL.100.OPAL	EUBEA ESTERNO Estruso Alluminio 100 cm Opalino	pag. 43	64,50 €	52,87 €
T145.AL.100.SAT	EUBEA ESTERNO Estruso Alluminio 100 cm Satinato	pag. 43	64,50 €	52,87 €
T145.AL.150.OPAL	EUBEA ESTERNO Estruso Alluminio 150 cm Opalino	pag. 43	97,00 €	79,51 €
T145.AL.150.SAT	EUBEA ESTERNO Estruso Alluminio 150 cm Satinato	pag. 43	97,00 €	79,51 €
T145.AL.200.OPAL	EUBEA ESTERNO Estruso Alluminio 200 cm Opalino	pag. 43	129,00 €	105,74 €
T145.AL.200.SAT	EUBEA ESTERNO Estruso Alluminio 200 cm Satinato	pag. 43	129,00 €	105,74 €
T165.GU10	SIRIS Incasso 1 Luce	pag. 147	19,00 €	15,57 €
T174.10	TEOS Parete 1 Luce	pag. 330	35,00 €	28,69 €
T174.11	TEOS Parete 2 Luci	pag. 331	47,00 €	38,52 €
T174.12	TEOS Parete 3 Luci	pag. 332	58,00 €	47,54 €
T177	ATTICA ORIENTABILE Incasso 1 Luce	pag. 152	21,00 €	17,21 €
T193	HERAEA Soffitto 3 Luci	pag. 316	72,00 €	59,02 €
T194	HERAEA Soffitto 5 Luci	pag. 317	131,00 €	107,38 €
T200	PELLENE Parete 1 Luce	pag. 336	29,00 €	23,77 €
T201	PELLENE Parete 2 Luci	pag. 337	45,00 €	36,89 €
T205	HERAEA Parete 3 Luci Up/Down	pag. 318	74,00 €	60,66 €
T208	HERMIONE Parete 1 Luce	pag. 340	42,00 €	34,43 €
T209	HERMIONE Parete 2 Luci	pag. 341	58,00 €	47,54 €
T210	HERMIONE 3 Luci	pag. 342	70,00 €	57,38 €
T220.W.50	CHALCIS Estruso Bianco 50 cm	pag. 52	17,00 €	13,93 €
T220.W.100	CHALCIS Estruso Bianco 100 cm	pag. 52	33,00 €	27,05 €
T220.W.150	CHALCIS Estruso Bianco 150 cm	pag. 52	50,00 €	40,98 €
T220.W.200	CHALCIS Estruso Bianco 200 cm	pag. 52	66,00 €	54,10 €
T220.AL.50	CHALCIS Estruso Alluminio 50 cm	pag. 52	17,00 €	13,93 €
T220.AL.100	CHALCIS Estruso Alluminio 100 cm	pag. 52	33,00 €	27,05 €
T220.AL.150	CHALCIS Estruso Alluminio 150 cm	pag. 52	50,00 €	40,98 €

			Including VAT IVA inclusa Inklusive MWST IVA incluido НДС включен	Excluding VAT Senza IVA Ohne MWST IVA excluido Без НДС
T220.AL.200	CHALCIS Estruso Alluminio 200 cm	pag. 52	66,00 €	54,10 €
T221.W.50	OROPUS Estruso Bianco 50 cm	pag. 48	22,00 €	18,03 €
T221.W.100	OROPUS Estruso Bianco 100 cm	pag. 48	43,00 €	35,25 €
T221.W.150	OROPUS Estruso Bianco 150 cm	pag. 48	66,00 €	54,10 €
T221.W.200	OROPUS Estruso Bianco 200 cm	pag. 48	86,00 €	70,49 €
T221.AL.50	OROPUS Estruso Alluminio 50 cm	pag. 48	22,00 €	18,03 €
T221.AL.100	OROPUS Estruso Alluminio 100 cm	pag. 48	43,00 €	35,25 €
T221.AL.150	OROPUS Estruso Alluminio 150 cm	pag. 48	66,00 €	54,10 €
T221.AL.200	OROPUS Estruso Alluminio 200 cm	pag. 48	86,00 €	70,49 €
T223	DELFI Parete 2 Luci	pag. 324	72,00 €	59,02 €
T255	HERAEA Incasso 2 Luci Cubi	pag. 142	51,00 €	41,80 €
T256	HERAEA Incasso 3 Luci Cubi	pag. 143	69,00 €	56,56 €
T257	HERAEA Incasso 5 Luci Cubi	pag. 144	156,00 €	127,87 €
T262	CHIO Soffitto 3 Luci In Linea	pag. 290	131,00 €	107,38 €
T263	CHIO Soffitto 3 Luci Forma Tonda	pag. 291	131,00 €	107,38 €
T264	CHIO Soffitto 5 Luci In Linea	pag. 292	178,00 €	145,90 €
T269	PARO Parete 3 Luci	pag. 320	69,00 €	56,56 €
T270	PARO Parete 5 Luci	pag. 323	93,00 €	76,23 €
T274	CHIO Soffitto 1 Luce	pag. 294	47,00 €	38,52 €
T278	CHIO Soffitto 2 Luci	pag. 295	39,00 €	31,97 €
T291	SIDE Soffitto 1 Luce Cubo LM GX53	pag. 302	59,00 €	48,36 €
T292	SIDE Soffitto 2 Luci Cubo LM GX53	pag. 303	109,00 €	89,34 €
T293	SIDE Soffitto 3 Luci Cubo LM GX53	pag. 304	137,00 €	112,30 €
T309.AL.50	METHONI Estruso Alluminio 50 cm	pag. 58	20,00 €	16,39 €
T309.AL.100	METHONI Estruso Alluminio 100 cm	pag. 58	40,00 €	32,79 €
T309.AL.150	METHONI Estruso Alluminio 150 cm	pag. 58	60,00 €	49,18 €
T309.AL.200	METHONI Estruso Alluminio 200 cm	pag. 58	79,00 €	64,75 €

Pricelist by code

Listino prezzi per codice
Preisliste nach code
Lista de precios por código
Прайс-лист по коду

				Including VAT IVA inclusa Inklusive MWST IVA incluido НДС включен	Excluding VAT Senza IVA Ohne MWST IVA excluido Без НДС
T310.AL.50	ICUS ESTERNO Estruso Alluminio 50 cm	pag. 62	45,00 €	36,89 €	
T310.AL.100	ICUS ESTERNO Estruso Alluminio 100 cm	pag. 62	48,00 €	39,34 €	
T310.AL.150	ICUS ESTERNO Estruso Alluminio 150 cm	pag. 62	51,00 €	41,80 €	
T310.AL.200	ICUS ESTERNO Estruso Alluminio 200 cm	pag. 62	54,00 €	44,26 €	
T311.10	PIRGOS Parete/Soffitto 100 cm	pag. 70	272,00 €	222,95 €	
T311.10.D	PIRGOS Parete/Soffitto 100 cm Dimmerabile	pag. 70	347,00 €	284,43 €	
T311.11	PIRGOS Parete/Soffitto 200 cm	pag. 71	356,00 €	291,80 €	
T311.11.D	PIRGOS Parete/Soffitto 200 cm Dimmerabile	pag. 71	431,00 €	353,28 €	
T311.30	PIRGOS Sospensione 100 cm	pag. 72	323,00 €	264,75 €	
T311.30.D	PIRGOS Sospensione 100 cm Dimmerabile	pag. 72	398,00 €	326,23 €	
T311.31	PIRGOS Sospensione 200 cm	pag. 73	408,00 €	334,43 €	
T311.31.D	PIRGOS Sospensione 200 cm Dimmerabile	pag. 73	483,00 €	395,90 €	
T311.50	PIRGOS Piantana 200 cm	pag. 74	569,00 €	466,39 €	
T319	CHIO Parete 1 Luce	pag. 296	52,00 €	42,62 €	
T320	CHIO Parete 2 Luci up	pag. 297	66,00 €	54,10 €	
T321	CHIO Parete 2 Luci Up/Down	pag. 298	66,00 €	54,10 €	
T322	CHIO Parete 3 Luci Up/Down	pag. 299	121,00 €	99,18 €	
T326	SIDE Parete 3 Luci Up/Down	pag. 306	127,00 €	104,10 €	
T332	THESSALY Incasso 1 Luce Bordo Nero	pag. 80	26,00 €	21,31 €	
T334	THESSALY Incasso 1 Luce Bordo Bianco	pag. 81	26,00 €	21,31 €	
T335	THESSALY Incasso 1 Luce Bordo Oro Spazzolato	pag. 82	26,00 €	21,31 €	
T336	THESSALY Incasso 1 Luce Bordo Rame SPazzolato	pag. 83	26,00 €	21,31 €	
T337	FILIATRA' Incasso 1 Luce Bianco	pag. 126	19,00 €	15,57 €	
T338	FILIATRA' Incasso 1 Luce Nero	pag. 127	25,00 €	20,49 €	
T339	DEMETRA Soffitto 1 Luce	pag. 267	35,00 €	28,69 €	
T353	DORIDE IP44 Incasso 1 Luce Round	pag. 138	31,00 €	25,41 €	
T354	DORIDE IP44 Incasso 1 Luce Square	pag. 139	33,00 €	27,05 €	

			Including VAT IVA inclusa Inklusive MWST IVA incluido НДС включен	Excluding VAT Senza IVA Ohne MWST IVA excluido Без НДС
T339	DEMETRA Soffitto 1 Luce	pag. 267	35,00 €	28,69 €
T353	DORIDE IP44 Incasso 1 Luce Round	pag. 138	31,00 €	25,41 €
T354	DORIDE IP44 Incasso 1 Luce Square	pag. 139	33,00 €	27,05 €
T356	LELANTO Incasso Orientabile 1 Luce Nero	pag. 120	31,00 €	25,41 €
T357	LELANTO Incasso Orientabile 2 Luci Nero	pag. 121	61,00 €	50,00 €
T358	DEMETRA Soffitto 2 Luci	pag. 268	57,00 €	46,72 €
T359	DEMETRA Soffitto 3 Luci	pag. 269	80,00 €	65,57 €
T360	DEMETRA Parete 1 Luce	pag. 271	46,00 €	37,70 €
T361	DEMETRA Parete 2 Luci Up	pag. 272	66,00 €	54,10 €
T362	DEMETRA Parete 2 Luci Up/Down	pag. 273	66,00 €	54,10 €
T367	SIDE SMALL Parete 2 Luci Up/Down	pag. 310	56,00 €	45,90 €
T368	SIDE SMALL Parete 2 Luci Up/Down	pag. 311	56,00 €	45,90 €
T369	SIDE SMALL 1 luce soffitto	pag. 312	46,00 €	37,70 €
T371	ANCHISE Soffitto 1 Luce	pag. 282	35,00 €	28,69 €
T372	ANCHISE Soffitto 2 Luci	pag. 283	60,00 €	49,18 €
T373	ANCHISE Soffitto 3 Luci	pag. 284	88,00 €	72,13 €
T374	ANCHISE Parete 1 Luce	pag. 286	42,00 €	34,43 €
T375	ANCHISE Parete 2 Luci Up/Down	pag. 287	63,00 €	51,64 €
T377	SIBARI Soffitto 2 Luci	pag. 276	50,00 €	40,98 €
T378	SIBARI Soffitto 3 Luci	pag. 277	75,00 €	61,48 €
T379	SIBARI Parete 1 Luce	pag. 278	42,00 €	34,43 €
T380	SIBARI Parete 2 Luci Up/Down	pag. 279	62,00 €	50,82 €
T381	FILIATRA' Incasso 1 Luce Quadrato Bianco	pag. 128	26,00 €	21,31 €
T382	FILIATRA' Incasso 1 Luce Quadrato Con Vetro Nero	pag. 129	33,00 €	27,05 €
T383	FILIATRA' Incasso 1 Luce Quadrato Con Vetro Bianco	pag. 130	27,00 €	22,13 €
T384	PHOCIS Incasso 1 Luce Filtro Alveolare	pag. 132	31,00 €	25,41 €
T385	CICLADI Parete Con Vetro 1 Luce	pag. 244	51,00 €	41,80 €

Pricelist by code

Listino prezzi per codice
Preisliste nach code
Lista de precios por código
Прайс-лист по коду

			Including VAT IVA inclusa Inklusive MWST IVA incluido НДС включен	Excluding VAT Senza IVA Ohne MWST IVA excluido Без НДС
T386	CICLADI Parete Con Vetro 2 Luci Up/Down	pag. 246	95,00 €	77,87 €
T387	CICLADI Soffitto 1 Luce	pag. 248	50,00 €	40,98 €
T388	CICLADI Soffitto 2 Luci	pag. 249	93,00 €	76,23 €
T389	CICLADI Soffitto 3 Luci	pag. 250	134,00 €	109,84 €
T390	THESSALY Incasso 1 Luce Bordo Raso Nero	pag. 88	26,00 €	21,31 €
T391	THESSALY Incasso 1 Luce Bordo Raso Bianco	pag. 89	26,00 €	21,31 €
T392	THESSALY Incasso 1 Luce Bordo Raso Oro Spazzolato	pag. 90	26,00 €	21,31 €
T393	THESSALY Incasso 1 Luce Bordo Raso Rame Spazzolato	pag. 91	26,00 €	21,31 €
T394	PATRA Parete 1 Luce	pag. 254	38,00 €	31,15 €
T395	PATRA Parete 2 Luci	pag. 256	57,00 €	46,72 €
T396	CICLADI Parete Con Vetro 2 Luci Up/Down	pag. 247	95,00 €	77,87 €
T397.1M.3000	LED STRIP 1 METRO 14,4W-3000	pag. 354	18,00 €	14,75 €
T397.2M.3000	LED STRIP 2 METRI 14,4W-3000	pag. 354	35,00 €	28,69 €
T397.3M.3000	LED STRIP 3 METRI 14,4W-3000	pag. 354	52,00 €	42,62 €
T397.4M.3000	LED STRIP 4 METRI 14,4W-3000	pag. 354	69,00 €	56,56 €
T397.5M.3000	LED STRIP 5 METRI 14,4W-3000	pag. 354	86,00 €	70,49 €
T397.1M.4000	LED STRIP 1 METRO 14,4W-4000	pag. 354	18,00 €	14,75 €
T397.2M.4000	LED STRIP 2 METRI 14,4W-4000	pag. 354	35,00 €	28,69 €
T397.3M.4000	LED STRIP 3 METRI 14,4W-4000	pag. 354	52,00 €	42,62 €
T397.4M.4000	LED STRIP 4 METRI 14,4W-4000	pag. 354	69,00 €	56,56 €
T397.5M.4000	LED STRIP 5 METRI 14,4W-4000	pag. 354	86,00 €	70,49 €
T398.1M.3000	LED STRIP 1 METRO 19,2W-3000	pag. 354	23,00 €	18,85 €
T398.2M.3000	LED STRIP 2 METRI 19,2W-3000	pag. 354	46,00 €	37,70 €
T398.3M.3000	LED STRIP 3 METRI 19,2W-3000	pag. 354	69,00 €	56,56 €
T398.4M.3000	LED STRIP 4 METRI 19,2W-3000	pag. 354	92,00 €	75,41 €
T398.5M.3000	LED STRIP 5 METRI 19,2W-3000	pag. 354	114,00 €	93,44 €
T398.1M.4000	LED STRIP 1 METRO 19,2W-4000	pag. 354	23,00 €	18,85 €

			Including VAT IVA inclusa Inklusive MWST IVA incluido НДС включен	Excluding VAT Senza IVA Ohne MWST IVA excluido Без НДС
T398.2M.4000	LED STRIP 2 METRI 19,2W-4000	pag. 354	46,00 €	37,70 €
T398.3M.4000	LED STRIP 3 METRI 19,2W-4000	pag. 354	69,00 €	56,56 €
T398.4M.4000	LED STRIP 4 METRI 19,2W-4000	pag. 354	92,00 €	75,41 €
T398.5M.4000	LED STRIP 5 METRI 19,2W-4000	pag. 354	114,00 €	93,44 €
T399	PITANE Parete/Soffitto Con Vetro 1 Luce	pag. 260	48,00 €	39,34 €
T400	PITANE Parete Con Vetro 2 Luci	pag. 261	89,00 €	72,95 €
T401	PITANE Parete/Soffitto Con Vetro 2 Luci	pag. 262	89,00 €	72,95 €
T402	PITANE Parete/Soffitto Con Vetro 3 Luci	pag. 263	123,00 €	100,82 €
T403	CICLADI TONDA Soffitto 1 Luce	pag. 238	57,00 €	46,72 €
T404	CICLADI TONDA Soffitto 2 Luci	pag. 239	106,00 €	86,89 €
T405	CICLADI TONDA Soffitto 3 Luci	pag. 240	153,00 €	125,41 €
T406	PROPILEI Sospensione 1 Luce 4 Anelli Colore	pag. 158	56,00 €	45,90 €
T407	PROPILEI Soffitto 4 Anelli Colore	pag. 164	53,00 €	43,44 €
T408	THESSALY Incasso 1 Luce Acciaio Spazzolato	pag. 84	26,00 €	21,31 €
T409	THESSALY Incasso 1 Luce Bronzo Spazzolato	pag. 85	26,00 €	21,31 €
T410	THESSALY Incasso 1 Luce Acciaio Spazzolato Raso	pag. 92	26,00 €	21,31 €
T411	THESSALY Incasso 1 Luce Bronzo Spazzolato Raso	pag. 93	26,00 €	21,31 €
T412	LELANTO Incasso Orientabile 1 Luce Bianca	pag. 122	31,00 €	25,41 €
T413	LELANTO Incasso Orientabile 2 Luci Bianca	pag. 123	61,00 €	50,00 €
T414	ELIS Incasso 1 Luce Raso Nero Fondo Nero	pag. 102	23,00 €	18,85 €
T415	ELIS Incasso 1 Luce Raso Bianco	pag. 103	23,00 €	18,85 €
T416	ELIS Incasso 1 Luce Raso Ottone	pag. 104	23,00 €	18,85 €
T417	ELIS Incasso 1 Luce Raso Rame	pag. 105	23,00 €	18,85 €
T418	ELIS Incasso 1 Luce Nero Fondo Nero	pag. 96	26,00 €	21,31 €
T419	ELIS Incasso 1 Luce Bianco	pag. 97	26,00 €	21,31 €
T420	ELIS Incasso 1 Luce Ottone	pag. 98	26,00 €	21,31 €
T421	ELIS Incasso 1 Luce Rame	pag. 99	26,00 €	21,31 €

Pricelist by code

Listino prezzi per codice
Preisliste nach code
Lista de precios por código
Прайс-лист по коду

			Including VAT IVA inclusa Inklusive MWST IVA incluido НДС включен	Excluding VAT Senza IVA Ohne MWST IVA excluido Без НДС
T422	NASSO Soffitto 1 Luce Tonda Nero	pag. 182	56,00 €	45,90 €
T423	NASSO Soffitto 1 Luce Tonda Bianco	pag. 183	56,00 €	45,90 €
T424	NASSO Soffitto 1 Luce Tonda Ottone	pag. 184	56,00 €	45,90 €
T425	NASSO Soffitto 1 Luce Tonda Rame	pag. 185	56,00 €	45,90 €
T426	NASSO Soffitto 1 Luce Quadrata Nero	pag. 172	56,00 €	45,90 €
T427	NASSO Soffitto 1 Luce Quadrata Bianco	pag. 173	56,00 €	45,90 €
T428	NASSO Soffitto 1 Luce Quadrata Ottone	pag. 174	56,00 €	45,90 €
T429	NASSO Soffitto 1 Luce Quadrata Rame	pag. 175	56,00 €	45,90 €
T430	NASSO Parete 1 Luce Tonda Nero	pag. 186	56,00 €	45,90 €
T431	NASSO Parete 1 Luce Tonda Bianco	pag. 187	56,00 €	45,90 €
T432	NASSO Parete 1 Luce Tonda Ottone	pag. 188	56,00 €	45,90 €
T433	NASSO Parete 1 Luce Tonda Rame	pag. 189	56,00 €	45,90 €
T434	NASSO Parete 1 Luce Quadrata Nero	pag. 176	56,00 €	45,90 €
T435	NASSO Parete 1 Luce Quadrata Bianco	pag. 177	56,00 €	45,90 €
T436	NASSO Parete 1 Luce Quadrata Ottone	pag. 178	56,00 €	45,90 €
T437	NASSO Parete 1 Luce Quadrata Rame	pag. 179	56,00 €	45,90 €
T438	SYME Soffitto 1 Luce Tonda Nero	pag. 202	59,00 €	48,36 €
T439	SYME Soffitto 1 Luce Tonda Bianco	pag. 203	59,00 €	48,36 €
T440	SYME Soffitto 1 Luce Tonda Ottone	pag. 204	59,00 €	48,36 €
T441	SYME Soffitto 1 Luce Tonda Rame	pag. 205	59,00 €	48,36 €
T442	SYME Soffitto 1 Luce Quadrata Nero	pag. 192	62,00 €	50,82 €
T443	SYME Soffitto 1 Luce Quadrata Bianco	pag. 193	62,00 €	50,82 €
T444	SYME Soffitto 1 Luce Quadrata Ottone	pag. 194	62,00 €	50,82 €
T445	SYME Soffitto 1 Luce Quadrata Rame	pag. 195	62,00 €	44,26 €
T446	SYME Parete 1 Luce Tonda Nero	pag. 206	79,00 €	56,56 €
T447	SYME Parete 1 Luce Tonda Bianco	pag. 207	79,00 €	56,56 €
T448	SYME Parete 1 Luce Tonda Ottone	pag. 208	79,00 €	56,56 €

			Including VAT IVA inclusa Inklusive MWST IVA incluido НДС включен	Excluding VAT Senza IVA Ohne MWST IVA excluido Без НДС
T449	SYME Parete 1 Luce Tonda Rame	pag. 209	79,00 €	56,56 €
T450	SYME Parete 1 Luce Quadrata Nero	pag. 196	79,00 €	59,02 €
T451	SYME Parete 1 Luce Quadrata Bianco	pag. 197	79,00 €	59,02 €
T452	SYME Parete 1 Luce Quadrata Ottone	pag. 198	79,00 €	59,02 €
T453	SYME Parete 1 Luce Quadrata Rame	pag. 199	79,00 €	59,02 €
T454	MYSIA Soffitto 1 Luce Bianca	pag. 212	38,00 €	31,15 €
T455	MYSIA Soffitto 2 Luci Bianca	pag. 213	61,00 €	50,00 €
T456	MYSIA Soffitto 3 Luci Bianca	pag. 214	86,00 €	70,49 €
T457	MYSIA Soffitto 1 Luce Grigia RAL 7039	pag. 216	38,00 €	31,15 €
T458	MYSIA Soffitto 2 Luci Grigia RAL 7039	pag. 217	61,00 €	50,00 €
T459	MYSIA Soffitto 3 Luci Grigia RAL 7039	pag. 218	86,00 €	70,49 €
T460	MYSIA Parete 1 Luce Bianca	pag. 220	42,00 €	34,43 €
T461	MYSIA Parete 2 Luci Bianca	pag. 221	57,00 €	46,72 €
T462	MYSIA Parete 1 Luce Grigia RAL 7039	pag. 224	42,00 €	34,43 €
T463	MYSIA Parete 2 Luci Grigia RAL 7039	pag. 225	57,00 €	46,72 €
T464	RHODIA Incasso Faretto Cob 1 Luce Nero	pag. 108	93,00 €	76,23 €
T465	RHODIA Incasso Faretto Cob 1 Luce Bianco	pag. 109	93,00 €	76,23 €
T466	RHODIA Incasso Faretto Cob 1 Luce Ottone	pag. 110	93,00 €	76,23 €
T467	RHODIA Incasso Faretto Cob 1 Luce Rame	pag. 111	93,00 €	76,23 €
T468	RHODIA Incasso Estraibile Faretto Cob 1 Luce Nero	pag. 114	99,00 €	81,15 €
T469	RHODIA Incasso Estraibile Faretto Cob 1 Luce Bianco	pag. 115	99,00 €	81,15 €
T470	RHODIA Incasso Estraibile Faretto Cob 1 Luce Ottone	pag. 116	99,00 €	81,15 €
T471	RHODIA Incasso Estraibile Faretto Cob 1 Luce Rame	pag. 117	99,00 €	81,15 €
T472	MILET Parete 1 Luce RAL 7039	pag. 230	45,00 €	36,89 €
T473	MILET Parete 2 Luci RAL 7039	pag. 231	81,00 €	66,39 €
T474	MILET Soffitto 1 Luce RAL 7039	pag. 232	48,00 €	39,34 €
T475	MILET Soffitto 2 Luci RAL 7039	pag. 233	88,00 €	72,13 €

Pricelist by code

Listino prezzi per codice
 Preisliste nach code
 Lista de precios por código
 Прайс-лист по коду

			Including VAT <small>IVA inclusa inklusive MWST IVA incluido НДС включен</small>	Excluding VAT <small>Senza IVA Ohne MWST IVA excluido Без НДС</small>
T476	MILET Soffitto 4 Luci RAL 7039	pag. 234	167,00 €	136,89 €
T477	MYSIA Parete 3 Luci Bianca	pag. 222	93,00 €	76,23 €
T478	MYSIA Parete 3 Luci Grigia RAL 7039	pag. 226	93,00 €	76,23 €
T479	RHODIA Incasso Faretto Cob 1 Luce Nero Dimmer Triac	pag. 108	108,00 €	88,52 €
T480	RHODIA Incasso Faretto Cob 1 Luce Bianco Dimmer Triac	pag. 109	108,00 €	88,52 €
T481	RHODIA Incasso Faretto Cob 1 Luce Ottone Dimmer Triac	pag. 110	108,00 €	88,52 €
T482	RHODIA Incasso Faretto Cob 1 Luce Rame Dimmer Triac	pag. 111	108,00 €	88,52 €
T483	RHODIA Incasso Estraibile Faretto Cob 1 Luce Nero Dimmer Triac	pag. 114	108,00 €	88,52 €
T484	RHODIA Incasso Estraibile Faretto Cob 1 Luce Bianco Dimmer Triac	pag. 115	115,00 €	94,26 €
T485	RHODIA Incasso Estraibile Faretto Cob 1 Luce Ottone Dimmer Triac	pag. 116	115,00 €	94,26 €
T486	RHODIA Incasso Estraibile Faretto Cob 1 Luce Rame Dimmer Triac	pag. 117	115,00 €	94,26 €
T487	PROPILEI Sospensione 1 Luce 4 Anelli Colore	pag. 162	49,00 €	40,16 €
T488	PROPILEI Soffitto 4 Anelli Colore	pag. 168	46,00 €	37,70 €



tecnicolighting.it

Headquarter / Showroom
 Viale dell'Industria, 21
 20037 Paderno Dugnano (MI) - Italy
 T. +39 02 9104958
 T. +39 02 9105178
 info@sforzinilluminazione.com

May 2024

Thanks to:

Concept & Art Direction: _blank design studio

Development: red-apple.it

Photo: Paolo Volontè



La tassa sullo smaltimento dei rifiuti degli apparecchi di illuminazione non è inclusa nel presente listino e viene versata al Consorzio Ecolight.

The lighting equipment waste disposal tax is not included in this price list and is paid to the Ecolight consortium.

Die Steuer zur Entsorgung von aus Beleuchtungen entstehender Abfälle ist in dieser Preisliste nicht eingeschlossen und wird an das Konsortium Ecolight entrichtet.

El impuesto de eliminación de residuos de aparatos de iluminación no está incluido en la presente lista de precios y se ingresa al Consorzio Ecolight.

Сбор за переработку отходов осветительных приборов не включен в данном прайс-листе. Он оплачивается Консорциуму Ecolight.

